

## **National Disaster Management Services (NDMS) Pilot Project for 120 locations**

The terrestrial communication networks are prone to failures during disasters as were the case in recent past in case of J&K and Uttarakhand. To mitigate this problem an integrated approach has been attempted to provide reliable Telecommunication infrastructure to the disaster managers during peace time as well as in the event of any disaster. The integrated approach is part of ICT services to assist the MHA, NDMA, NDRF HQ, local administration in taking appropriate decisions. For this purpose a pilot project titled as “National Disaster Management Services (NDMS)” has been conceived for 120 locations as listed below:

- i. MHA - 01
- ii. NDMA - 01
- iii. NDRF HQ - 01
- iv. All States/UTs HQ - 36
- v. Selected Districts - 81

which is based on providing reliable VSAT communication backed up with terrestrial network and HF Radios.

The project is being implemented by Bharat Sanchar Nigam Ltd. (BSNL).

The scope of the pilot project is to provide the reliable telecommunication infrastructure and technical support for Emergency Operation Centre (EOC) operations at MHA, NDMA, NDRF HQ, States & selected vulnerable Districts.

The broad objects of the project are as follows:

- Voice Calls between EOCs of Disaster affected Districts, States, NDMA, NDRF HQ and MHA during disaster on priority and peace time to other EOCs in a restricted way depending upon the availability of Bandwidth.
- Internet, Email, Landline (outgoing) & Mobile (outgoing), Web Services from the disaster site freely and to other places in a restricted way depending upon the availability of Bandwidth.
- EPABX feature will be made available through the Universal Gateway which will have the facility to transfer the Telephone Calls on any of the Media including HF, Satellite, Terrestrial Network or any other mode including intercoms and IVRS
- HF Radio connectivity
- Receive information/services as provided by various forecasting and warning agencies (CWC, IMD, INCOIS, GSI, etc.) from their portal.
- Provide single view of disaster from the disaster affected site as far as possible to all the stakeholders through integration of various information (Audio, Video and Data) feeds.
- Provide platform for strategy and information interchange with MHA, NDMA, NDRF HQ, States/UTs/Selected Districts and other disaster relief agencies.

## Proposed Solution

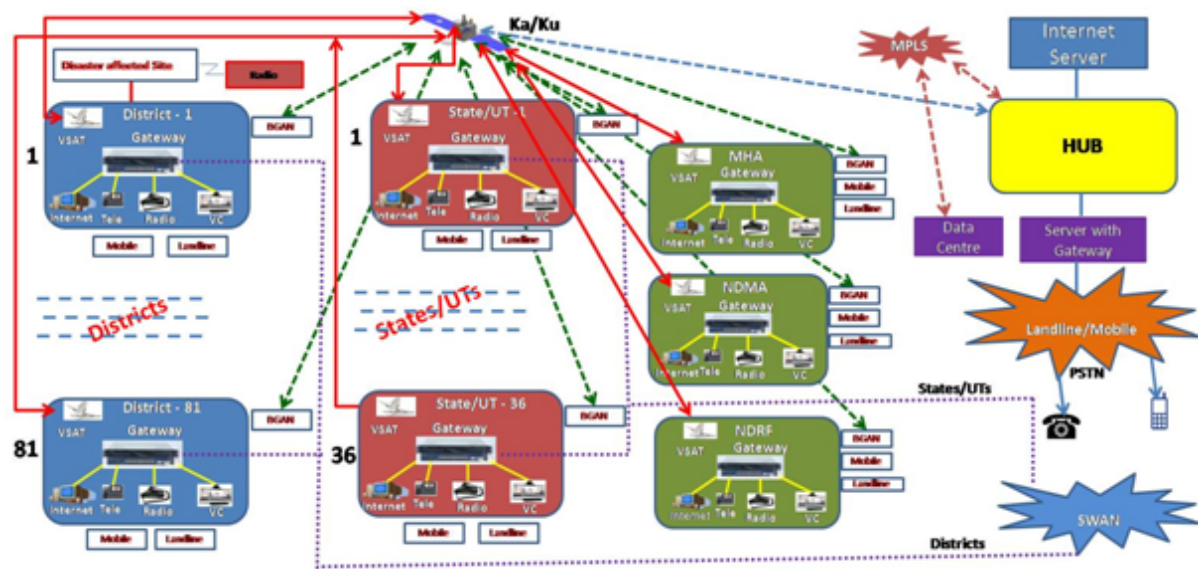

This Scheme is being implemented in Himachal Pradesh in the District Mandi, District Kangra and State headquarters.