

केवल आधिकारिक प्रयोग के लिए
For official use only

भारत सरकार/ Government of India
भारतीय भूवैज्ञानिक सर्वेक्षण (भा. भू. स.)/ Geological Survey of India (GSI)



हिमाचल प्रदेश के मंडी स्थित तारणा पहाड़ी एवं कांगनीधार भूस्खलन पर विस्तृत भू-
तकनीकी जांच पर प्रतिवेदन

(मद संख्या: M4EGG/C/NR/SU-PHP/2023/46620)

(टोपोशीट संख्या: 53 ए /14)

(मिशन - IV/ कार्यसत्र: 2023-24)

**A REPORT ON THE SITE-SPECIFIC GEOTECHNICAL INVESTIGATIONS OF
TARNA HILL LANDSLIDE AND KANGANIDHAR LANDSLIDE, MANDI
DISTRICT, HIMACHAL PRADESH**

[Item No. M4EGG/C/NR/SU-PHP/2023/46620]

(Toposheet No.: 53A/14)

(Mission - IV/ Field Season: 2023-24)

द्वारा :

श्रेयसी महापात्रा, वरिष्ठ भूवैज्ञानिक
तृप्ति बाबा, वरिष्ठ भूवैज्ञानिक

भारतीय भूवैज्ञानिक सर्वेक्षण, उत्तरी क्षेत्र

By:

Shreyasi Mahapatra, Senior Geologist
Tripti Baba, Senior Geologist
Geological Survey of India, Northern Region

अभियांत्रिकी भूविज्ञान प्रभाग /Engineering Geology Division
भारतीय भूवैज्ञानिक सर्वेक्षण, उत्तरी क्षेत्र / Geological Survey of India, Northern Region
राज्य इकाई: पंजाब, हरियाणा तथा हि. प्र. / State Unit: Punjab, Haryana and H.P.
चण्डीगढ़ - 160 020 (के. शा. प्र.) / Chandigarh - 160 020 (U.T.)

मार्च/March, 2024

**A REPORT ON THE SITE-SPECIFIC GEOTECHNICAL INVESTIGATIONS OF
TARNA HILL LANDSLIDE AND KANGANIDHAR LANDSLIDE, MANDI DISTRICT,
HIMACHAL PRADESH**

[Item No. M4EGG/C/NR/SU-PHP/2023/46620]
(Field Season: 2023-24)

By
Shreyasi Mahapatra, Senior Geologist
Tripti Baba, Senior Geologist
Geological Survey of India, Northern Region

CONTENT		PAGE NO
<i>Abstract</i>		
CHAPTER 1: INTRODUCTION		1-8
1	Introduction	1
1.1	Objective	1
1.2	Location and accessibility	2
1.3	Climate, Rainfall and Hydrological set up	3
1.4	Regional Geomorphology and Soil Types of Mandi	5
1.5	Seismicity of the area	5
1.6	Flora and Fauna	7
1.7	Acknowledgements	7
1.8	Previous work and background history	7
1.9	Present work	8
CHAPTER 2: GEOLOGY		10-11
2.0	Regional Geology of the area	10
CHAPTER 3: METHODOLOGY		12-24
3.0	Methodology	12
3.1	Rock Mass Rating (RMR):	14
	3.1.1. Uniaxial Compressive Strength (UCS)	14
	3.1.2. Determination of Rock Quality Designate (RQD)	16
3.2	Slope Mass Rating (SMR):	16
3.3	Factor of Safety (FoS):	18
	3.3.1. Limit Equilibrium Method	19
	3.3.2. Bishop Method	19
	3.3.3. Spencer Method	21
	3.3.4. Finite Element Method	22
	3.3.5. Strength Reduction Method	22
	3.3.6. Circular Failure Chart (CFC)	23
CHAPTER 4: TARNA HIL LANDSLIDE		25-58
4.0	Introduction	25
4.1	Morphometric details of the Study Area	28

	4.1.1	Crown portion	29
	4.1.2	Head portion of the Tarna Hill Landslide	30
	4.1.3	Belly Portion of landslide	31
	4.1.4	Zone of Accumulation/ Toe Portion of Landslide	32
4.2	Slope forming material		33
4.3	Hydrology		33
4.4	Structural details		33
4.5	Geological Observations		34
4.6	Geological Profile/Sections		36
	4.6.1	Geological-profile of X-Y	36
4.7	Sample collection		38
	4.7.1	Undisturbed Soil samples	38
4.8	Geotechnical properties of soil samples of Tarna Hill Landslide		39
	4.8.1	Grain size analysis	40
	4.8.2	Density of soil	41
	4.8.3	Natural moisture content	42
	4.8.4	Specific gravity	43
	4.8.5	Permeability	43
	4.8.6	Shear strength	43
	4.8.7	Atterberg Limit	44
4.9	Rock Mass Characterization		47
	4.9.1	Weathering Grade	47
	4.9.2	Determination of Rock Quality Designate (RQD):	48
	4.9.3	Uniaxial Compressive Strength (UCS)	48
	4.9.4	Rock Mass Rating (RMR)	48
4.10	Slope Stability Analysis		49
	4.10.1	Slope Mass Rating (SMR):	49
	4.10.2	Kinematic Analysis	50
	4.10.3	Results of Kinematic Checks	53
	4.10.4	Overall Stability Assessment of the Tarna Hill Landslide Zone	53
4.11	Geotechnical properties of the rock sample		53
4.12	Discussions		53
4.13	Slope stability analysis		54
4.14	Contributing and Causative Factors		56
4.15	Geo-genic Contributing Factors		56
4.16	Anthropogenic Causative Factors		56
4.17	Type of Slide		57
4.18	Recommendation/remedial measures		57
4.19	Instrumentation		58
	4.19.1	Subsurface Instruments	58

	4.19.2	Surface Instruments	58
CHAPTER 5: KANGNIDHAR LANDSLIDE			59-81
5.0	Introduction		59
5.1	Morphometric details of the Study Area		61
	5.1.1	Crown portion	61
	5.1.2	Head portion of the Tarna Hill Landslide	62
	5.1.3	Belly Portion of landslide	62
	5.1.4	Zone of Accumulation/ Toe Portion of Landslide	63
5.2	Slope forming material		63
5.3	Hydrology		63
5.4	Structural details		63
5.5	Geological Observations		65
5.6	Geological Profile/Sections		65
	5.6.1	Geological-profile of X-Y	65
5.7	Sample collection		66
	5.7.1	Undisturbed Soil samples	66
5.8	Geotechnical properties of soil samples of Tarna Hill Landslide		67
	5.8.1	Grain size analysis	67
	5.8.2	Density	68
	5.8.3	Natural moisture content	69
	5.8.4	Specific gravity	69
	5.8.5	Permeability	69
	4.8.6	Shear strength	69
	4.8.7	Atterberg Limit	70
5.9	Rock Mass Characterization		70
	5.9.1	Weathering Grade	71
	5.9.2	Determination of Rock Quality Designate (RQD):	71
	5.9.3	Uniaxial Compressive Strength (UCS)	71
	5.9.4	Rock Mass Rating (RMR)	71
5.10	Slope Stability Analysis		72
	5.10.1	Slope Mass Rating (SMR):	72
	5.10.2	Kinematic Analysis	74
	5.10.3	Results of Kinematic Checks	76
	5.10.4	Overall Stability Assessment of the Tarna Hill Landslide Zone	76
5.11	Geotechnical properties of the rock sample		77
5.12	Discussions		77
5.13	Slope stability analysis		78
5.14	Contributing and Causative Factors		79
5.15	Geo-genic Contributing Factors		79
5.16	Anthropogenic Causative Factors		80

	5.17	Type of Slide	80
	5.18	Recommendation/remedial measures	80
	5.19	Instrumentation	81
	5.19.1	Subsurface Instruments	81

REFERENCES

ANNEXURE

Annexure I Report on the preliminary assessment of debris slide at Tarna Hills, Sarkaghat and Dharampur areas of Mandi District Himachal Pradesh

Annexure II 42 Point Performa for Tarna Hill and Kanganidhar landslide

Annexure III Determination of rock and soil properties by NIT, Hamirpur, Himachal Pradesh

PLATES

Plate I Geological Map of Tarna Hill Landslide, District Mandi, Himachal Pradesh.

Plate II X-Y Geological section of Tarna Hill Landslide, Mandi, Himachal Pradesh.

Plate III Geological Map of Kanganidhar Landslide, District Mandi, Himachal Pradesh.

Plate IV X-Y Geological section of Kanganidhar Landslide, Mandi, Himachal Pradesh

हिमाचल प्रदेश के मंडी स्थित तारणा पहाड़ी एवं कांगनीधार भूस्खलन पर विस्तृत भू-तकनीकी जांच पर प्रतिवेदन

(मद संख्या: M4EGG/C/NR/SU-PHP/2023/46620)

(टोपोशीट संख्या: 53 ए /14)

(मिशन - IV/ कार्यसत्र: 2023-24)

सारांश

हिमाचल प्रदेश के पहाड़ी और पहाड़ी परिदृश्य को चतुर्धातुक काल के दौरान हिमनद और नदी गतिविधियों द्वारा आकार दिया गया है, जिससे यह प्राकृतिक आपदाओं के लिए प्रवण हो जाता है जो राज्य की प्रगति को बाधित करते हैं। 2023 के मानसून के दौरान मंडी जिले में विनाशकारी भूस्खलन के जवाब में, भारत में भूस्खलन अध्ययन के लिए नोडल एजेंसी, भारतीय भूवैज्ञानिक सर्वेक्षण ने एक व्यापक अध्ययन किया। यह जांच तारणा पहाड़ी और कांगनीधार भूस्खलन पर केंद्रित थी, जिसमें 1:1000 के पैमाने पर विस्तृत भूवैज्ञानिक मानचित्रण, प्रोफाइल विश्लेषण और भू-तकनीकी मापदंडों का आकलन करने और प्रभावित क्षेत्रों के लिए शमन उपायों का प्रस्ताव करने के लिए मिट्टी के नमूने एकत्र करना शामिल था।

मंडी जिले में पर्वत श्रृंखलाओं, पहाड़ियों और घाटियों का एक जटिल मिश्रण है। कुछ छोटी अंतरमोंटेन घाटियाँ कम हिमालयी श्रृंखलाओं में पाई जा सकती हैं, जिनकी औसत ऊँचाई औसत समुद्र तल से लगभग 790 मीटर और एन. एन. ई. की ओर एक सामान्य ढलान है। घाटी के तल को नीची पहाड़ियों, पहाड़ियों के साथ छतों और रुक-रुक कर कम जलोढ़ मैदानों की विशेषता है।

भूगर्भीय दृष्टिकोण से, भूस्खलन क्षेत्र मुख्य रूप से सुंदरनगर समूह के मंडी ज्वालामुखी से उत्पन्न होने वाले बेसाल्ट और कार्टेज एरेनाइट से बना है। कुल्लू थ्रस्ट और मंडी-सुंदरनगर थ्रस्ट के निकट होने के कारण इस क्षेत्र की चट्टानें बड़े पैमाने पर टूट गई हैं और जुड़ गई हैं। भूस्खलन के आधार पर मौसम सूचकांक W3-W4 से लेकर ऊपरी खंड के पास W5 में परिवर्तित हो रहा है। (ISRM, 1981a). भारतीय भूवैज्ञानिक सर्वेक्षण (जीएसआई, 2018-2019) ने इस क्षेत्र को मध्यम भूस्खलन संवेदनशीलता क्षेत्र के रूप में वर्गीकृत किया है। 3-5 मीटर की अनुमानित मोटाई के साथ मध्यम रूप से कॉम्पैक्ट मिट्टी और पेलियो-डिब्रिस सामग्री का एक मोटा बोझ इस क्षेत्र को कवर करता है।

मंगवाई-रेवालसर रोड के साथ सुकेती खुद नदी के बाएं किनारे पर स्थित, तरना हिल भूस्खलन 50 मीटर ऊंचाई और 120 मीटर चौड़ाई में फैला हुआ है, जिससे मंगवाई रोड का लगभग 100 मीटर प्रभावित होता है। स्लाइड की ऊपरी सीमा को छतों और स्लाइड क्षेत्र में घरों के लिए एक जोड़ने वाले मार्ग द्वारा चित्रित किया गया है। सक्रिय स्कार्प में एक खड़ी ढलान है जो बेसाल्ट और कार्टेज एरेनाइट बोल्टर सहित ढीले मलबे की सामग्री को उजागर करती है।

मिट्टी के नमूनों के भू-तकनीकी विश्लेषण से पता चलता है कि मुख्य रूप से बजरी से सिल्टी रेत, अच्छी तरह से वर्गीकृत, ढीली, सामंजस्यहीन रेत और जैविक मिट्टी के साथ बजरी। मिट्टी के नमूने की पारगम्यता मध्यम से महीन रेत श्रेणी के भीतर एक वर्गीकरण को इंगित करती है। उजागर चट्टान द्रव्यमान पर जोड़ों के तीन समूह पहचाने जाते हैं। जे1 समतलीय विफलता के लिए अतिसंवेदनशील है, जबकि जे1, जे2 और जे3 का प्रतिच्छेदन वेज बनाता है जो ढलान प्रोफाइल पर विफल हो सकता है। रॉक मास रेटिंग (आर. एम. आर.) 64 से 69 तक होती है, जो स्लाइड ज़ोन में चट्टान को वर्ग II के रूप में वर्गीकृत करती है, जो अच्छी स्थिति का संकेत देती है। स्लोप मास रेटिंग (SMR) अध्ययन क्षेत्र के भीतर 30.00 से 70.00 तक भिन्न होती है, जो खराब (वर्ग IV) से अच्छी स्थिति तक की सीमा का सुझाव देती है। (Class II).

सुकेती खुड़ के दाहिने किनारे पर स्थित कंगनीधर भूस्खलन को भारी वर्षा से उत्पन्न मलबे के खिसकने के रूप में वर्गीकृत किया गया है। इसके कारण ढलान संतृप्ति हुई और बाद में ढलान के मलबे कमजोर हो गए, जिसके परिणामस्वरूप घूर्णन विफलता हुई। स्लाइड के आयाम 30 मीटर ऊंचाई और 80 मीटर चौड़ाई में थे, जो राष्ट्रीय राजमार्ग सड़क के लगभग 100 मीटर को प्रभावित करते थे।

सक्रिय स्कार्प खड़ी होती है, जो असमान चतुर्धातुक जमा के साथ-साथ बेसाल्ट और क्वार्ट्ज एरेनाइट बोल्टर की ढीली असंगठित मलबे की सामग्री को प्रकट करती है। मिट्टी के नमूनों के भू-तकनीकी विश्लेषण से पता चला कि ढीली, सामंजस्यहीन रेत और बजरी वाली मिट्टी मध्यम से महीन रेत की श्रेणी में आती है। उजागर चट्टान द्रव्यमान के साथ जोड़ों के तीन सेटों की पहचान की गई थी। आर. एम. आर. 64 से 69 तक भिन्न होता है, जो स्लाइड क्षेत्र में उजागर चट्टान को अच्छी स्थिति में वर्ग II के रूप में वर्गीकृत करता है। अध्ययन क्षेत्र में चट्टान के द्रव्यमान का एस. एम. आर. मान इंगित करता है कि चट्टान की ढलान भी अच्छी स्थिति में है। .

सीएफसी चार्ट विधि का उपयोग करते हुए, सुरक्षा के कारक को निर्धारित करने के लिए प्रत्येक भूस्खलन के लिए ढलान स्थिरता विश्लेषण किया गया था।

अनुशंसित सुधारात्मक उपायों में उचित लाइन वाले जल निकासी का कार्यान्वयन, अवरुद्ध नालों की नियमित सफाई, सतह संग्रह के प्रावधानों के साथ क्षतिग्रस्त खंडों का पुनर्निर्माण, पर्याप्त प्रतिधारण संरचनाओं की स्थापना, क्षतिग्रस्त प्रतिधारण दीवारों की मरम्मत या प्रतिस्थापन और अतिसंवेदनशील ढलानों पर जलभराव की रोकथाम शामिल है।

ये निष्कर्ष और सुझाए गए कार्य हिमाचल प्रदेश में भूस्खलन के जोखिमों को प्रभावी ढंग से प्रबंधित करने के लिए मूल्यवान अंतर्दृष्टि प्रदान करते हैं, विशेष रूप से मंडी जिले के सर्वेक्षण किए गए क्षेत्रों में। प्राकृतिक आपदाओं के प्रभाव को कम करने, सतत विकास को बढ़ावा देने और क्षेत्र में स्थानीय आबादी और बुनियादी ढांचे की सुरक्षा सुनिश्चित करने के लिए उचित शमन रणनीतियों को अपनाना अनिवार्य है।

**A REPORT ON THE SITE-SPECIFIC GEOTECHNICAL INVESTIGATIONS OF
TARNA HILL LANDSLIDE AND KANGANIDHAR LANDSLIDE, MANDI
DISTRICT, HIMACHAL PRADESH**

[Item No. M4EGG/C/NR/SU-PHP/2023/46620]

(Toposheet No.: 53A/14)

(Mission - IV/ Field Season: 2023-24)

Abstract

The hilly and mountainous landscape of Himachal Pradesh has been shaped by glacial and fluvial activities during the Quaternary period, making it prone to natural disasters that impede the state's progress. In response to devastating landslides in Mandi district during the monsoon of 2023, the Geological Survey of India, the nodal agency for landslide studies in India, conducted a comprehensive study. The investigation centred on the Tarna Hill and Kanganidhar Landslides, involving detailed geological mapping on a scale of 1:1000, profile analysis, and soil sample collection to assess geotechnical parameters and propose mitigation measures for the affected areas.

The Mandi district showcases a complex blend of mountain ranges, hills, and valleys. Some small intermontane valleys can be found in the lesser Himalayan ranges, with an average altitude of around 790 m above mean sea level and a general slope towards NNE. The valley floor is rolling and characterized by low hillocks, terraces along the hills, and intermittent low alluvial plains.

From a geological perspective, the landslide area is mainly made up of basalt and quartz arenite originating from the Mandi Volcanics of the Sundernagar Group. The rocks in this vicinity are extensively fractured and jointed due to their close proximity to the Kullu Thrust and Mandi-Sundernagar Thrust. The Weathering index at the base of the landslide ranges from W3-W4, transitioning to W5 near the upper section (ISRM, 1981a). The Geological Survey of India (GSI, 2018-2019) has classified this area as a Moderate landslide susceptibility zone. A thick overburden of moderately compact soil and paleo-debris material, with an estimated thickness of 3-5 m, covers the region.

Located on the left bank of Suketi Khud River along the Mangwai-Rewalsar road, the Tarna Hill landslide spans 50 meters in height and 120 meters in width, impacting nearly 100 meters of the Mangwai road. The upper limit of the slide is delineated by terraces and a connecting pathway for houses across the slide zone. The active scarp features a steep slope exposing loose debris material, including basalt and quartz arenite boulders.

Geotechnical analysis of soil samples reveals predominantly gravel to silty sand, well-graded, loose, cohesionless sand and gravel with organic clay. The permeability of the soil sample indicates a classification within the medium to fine sand category. There are three sets of joints identified on the exposed rock mass. J_1 is susceptible to planar failure, while the intersection of J_1 , J_2 , and J_3 forms wedges that may fail on the slope profile. The Rock Mass Rating (RMR) ranges from 64 to 69, classifying the rock in the slide zone as Class II, indicating Good condition. The Slope Mass Rating (SMR) varies from 30.00 to 70.00 within the study area, suggesting a range from Bad (Class IV) to Good condition (Class II).

The Kanganidhar landslide, situated on the right bank of Suketi Khud, is classified as a debris slide triggered by heavy rainfall. This led to slope saturation and subsequent weakening of the slope debris, resulting in rotational failure. The dimensions of the slide were 30 meters in height and 80 meters in width, affecting nearly 100 meters of the National Highway road.

The active scarp is steep, revealing loose unconsolidated debris material of undifferentiated quaternary deposit, as well as basalt and quartz arenite boulders. Geotechnical analysis of soil samples showed loose, cohesionless sand and gravel soils falling under the medium to fine sand category. Three sets of joints were identified along the exposed rock mass. The RMR varies from 64 to 69, classifying the rock exposed at the slide zone as Class II in Good condition. The SMR value of the rock mass in the study area indicates the rock slope is also in Good condition (Class II).

Utilizing the CFC Chart method, slope stability analysis was conducted for each landslide to determine the Factor of Safety (FoS).

The recommended corrective measures include the implementation of proper lined channelized drainage, regular cleaning of choked nalas, reconstruction of damaged sections with enhanced surface collection provisions, installation of adequate retaining structures, repair or replacement of damaged retaining walls, and prevention of waterlogging along susceptible slopes.

These findings and suggested actions offer valuable insights for effectively managing landslide risks in Himachal Pradesh, particularly in the surveyed areas of Mandi District. It is imperative to adopt appropriate mitigation strategies to minimize the impact of natural disasters, foster sustainable development, and ensure the safety and security of the local population and infrastructure in the region.

CHAPTER-1

INTRODUCTION

1.0. INTRODUCTION

With the onset of the southwesterly monsoons of 2023, the state of Himachal Pradesh encountered many devastating landslides and cloud bursts causing widespread damage to life and property. The heavy torrential rains during the month of July led to flash floods like situations at a number of places in Mandi District, Himachal Pradesh. The flash floods caused incremental erosion of the toe along the river beds further making the slope highly vulnerable to failure. The subsequent continuous precipitation from 12th to 14th of August, 2023 finally led to slope failure along the unstable zones.

Consequent upon the incidences of the landslide and the request received from the office of Deputy Commissioner, Mandi, a team of Geoscientists from Geological Survey of India, Chandigarh carried out the preliminary studies of the landslides in and around Tarna Hill, Sarkaghat, Riyur and Phagwaon from 04.09.2023 to 11.09.2023. Keeping in view of the strategic importance of the Tarna Hill area, Mandi, and as per the directions received from DC, Mandi during the Meeting held on 11.09.2023, a detailed investigation at Tarna Hill, and Kanganidhar Hill was carried out by a team of geoscientists deputed from GSI, Chandigarh, under the guidance of Sh. P.T. Ilamkar, Director, Engineering Geology Division, SUPPH, Chandigarh from 26.09.23 to 13.10.23. T

he prefatory note submitted to the office of DDMA, Mandi with requisite protection measures is enclosed with this report as Annexure I. The post-monsoon fieldwork was carried out by Smt. Shreyasi Mahapatra, Senior Geologist, and Ms. Tripti Baba, Senior Geologist. from 28.09.2023 to 08.10.2023, Shri Manish, Surveyor, HPPWD, has rendered his services in the field between 28th September and 10th October 2023 and in addition, Shri Sher Singh, Sr. Draftsman, Office of Sr. Architect, Mandi rendered his services for the preparation of the final Geological Map of Tarna and Kanganidhar on a scale of 1:1000. The undisturbed soil samples collected during the field work were submitted to the DDMA, Mandi for determination of the geotechnical properties of the material.

1.1. OBJECTIVE

The objectives of the present investigations are as follows:

- i. To prepare topographical and geological mapping of the landslide area on a 1:1000 scale.
- ii. To carry out geological and geotechnical assessment of landslide with a view to understand causative factors and their failure mechanism.

- iii. To carry out slope stability assessment of the landslides
- iv. To formulate suggestions/remedial measures with a view to reduce risk to life and property.

1.2 LOCATION AND ACCESSIBILITY

Mandi district, covering an area of 3950 Sq. Km. is centrally located hilly district of Himachal Pradesh having a few isolated patches of small and fertile valleys. The district, with its headquarter at Mandi town, lies between latitude 31°13' and 32° 05' N longitude and 76°37' and 77°25' E falling in parts of Survey of India Degree sheets no 53A, 53E and 52D.

The geographical coordinates of the landslide incidence of Tarna Hill are latitude 31° 42'' 19'' N and longitude 76° 55'59'' E along the Mangwai road on the left bank of Suketi *Khud*. The Kanganidhar landslide is located at latitude 31°42'18'' N and longitude 76°56'6'' E, on the NH-154 (Rewalsar-Mandi Road). The landslide incidence falls in Survey of India Toposheet No. 53A/14, nearly 1.8 Km southwest from Mandi town, Mandi District, Himachal Pradesh. The location map of the Tarna hill landslide and Kanganidhar is shown in **Figure 1.1**.



Figure 1.1: Location map of the Tarna Hill landslide, Mandi District, Himachal Pradesh.

The general elevation of areas affected by the landslide incidences ranges from 700 m to 1400 m msl. Mandi is one of the largest cities of Himachal Pradesh and is well connected to all major cities of Himachal Pradesh, Punjab and Delhi. The area is approachable by all-weather road and can be accessed from Chandigarh via Chandigarh-Mandi-Manali National Highway(NH-21) and from Shimla via Shimla-Bilaspur-Mandi National Highway. The nearest airport is the Kullu Airport at Bhuntar,

about 75 km from Mandi city. This is a small domestic airport. There is currently no railway connectivity to Mandi. The nearest railway station is the Jogindernagar Railway Station (Narrow Gauge) almost 50 km from the city.

1.3 CLIMATE, RAINFALL AND HYDROLOGICAL SETUP

The climate of Mandi is composite having hot summers and cold winters. Mandi generally experiences rainfalls during end of the summer season. These areas enjoy a Wet-sub temperate climate along the foothills (450–900 m) as against the Dry-cold alpine climate with snow fall at higher altitudes (2400 m – 4800 m). The annual range of temperature is 6.7 to 39.6 °C (44.1 to 103.3 °F). The average temperature during summer is between 18.9 and 39.6 °C (66.0 and 103.3 °F), and between 6.7 and 26.2 °C (44.1 and 79.2 °F) during winter. Monthly precipitation varies between 25.4 millimeters (1.00 in) in November to 228.6 millimeters (9.00 in) in August. It is typically around 58.3 millimeters (2.30 in) per month during winter and spring and around 101.6 millimeters (4.00 in) in June as the monsoon approaches. The average total annual precipitation is 832 millimeters (32.8 in) (CGWB, 2013)

In the year 2023 the state witnessed an unprecedented high rainfall, intensifying both landslide and erosion activities throughout the city. The heavy precipitation was by quantified by the total rainfall recorded at different locations, based on IMD data analysis for the period from 2014- 2023, during months of April to August. Based on the plotting of IMD data, it was observed that during 2023, heavy rainfall was recorded at all locations, with the total recorded rainfall varying from 186 mm, 254 mm, 287 mm, 529 mm and 694 mm respectively, from April to August 2023, and was considerably on the higher side in comparison to the total rainfall during the preceding years in Mandi district. The rainfall trend during the years from 2020 to 2023 during the southwesterly monsoon season of April to August is given in **Figure 1.2** (Source: Data plotted from precipitation values available on IMD website, <https://mausam.imd.gov.in/shimla>).

The given rainfall data analysis also revealed that although the total rainfall increased in each month, the numbers of rainy days decreased in each month, reflecting heavy spells of rainfall in 2023.

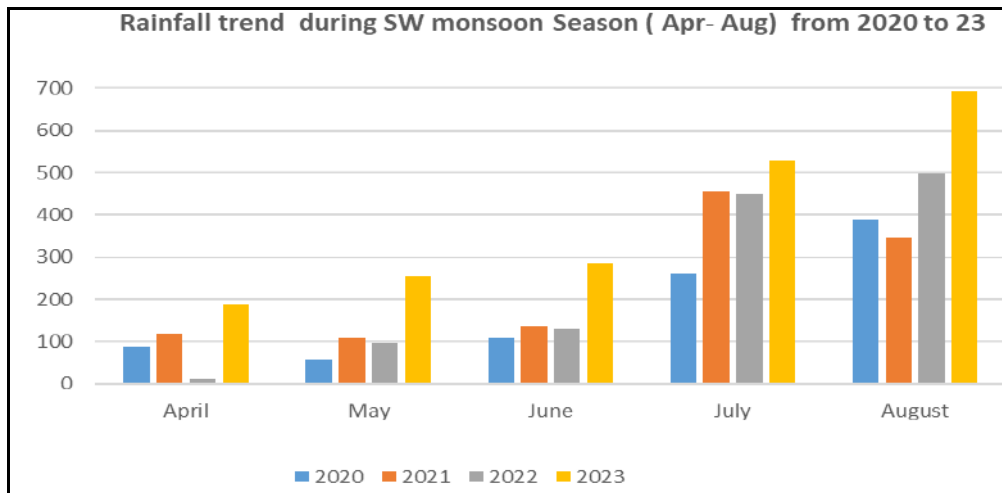

Figure 1.2: Plot showing trend of Rainfall over the period of four years in Mandi Distt. Himachal Pradesh.

During the initial week of July, the region experienced extended periods of intense, unrelenting spells of torrential rainfall, saturating the soil. This pre-soaked condition was compounded by another spell of heavy persistent rainfall over the weekend of August 13-15, 2023, which caused havoc in the hilly region of Mandi (<http://hydro.imd.gov.in>).

The Beas and Sutlej rivers form the major drainage system in the district. The river Beas and its tributaries drain about 70% of the district area in the northern part, whereas the area in the south is drained mainly by the river Sutlej. Suketi *Khud* and its tributaries chiefly drain the Balh valley. The Suketi *Khud* maintains a perennial flow, because of effluent seepage from groundwater. There are three important lakes in the district, namely Rewalsar, Prasher and Kamrunag (CGWB, 2013).

Hydrogeologically, the district is divided into two distinct and well defined units viz. *porous* formations constituted by unconsolidated sediments and the *fissured* formations or hard rock formation constituted mainly by semi-consolidated to consolidated rocks. The weathered and fractured hard rocks are favorable for groundwater aquifer. The fracture or fault zones form potential ground water zones. Ground water in the hilly areas of Mandi district of Himachal Pradesh oozes in the form of seepages, springs. Construction of bowris are common in areas with oozing spring/seepage zones for collection and storage of water.

1.4 REGIONAL GEOMORPHOLOGY AND SOIL TYPES OF MANDI

Mandi district presents an intricate mosaic of mountain ranges, hills and valleys. It is primarily a hilly district with altitudes ranging from 550 m near Sandhol where the Beas River leaves the district, to about 3960 m msl near Kullu border. There is a general increase in elevation from west to east and from south to north. Master slope is south-westerly. The southwestern part consists of Siwalik ranges

having scarped slopes.

There are few small intermontane valleys located in the lesser Himalayan ranges, having an average altitude of about 790 m above msl and have a general slope towards NNE. The valley floor is undulating and is marked by low hillocks and terraces fringing the hills and intervening low alluvial plains.

Two types of soils are mainly observed in the district viz. Sub-Mountainous Soil and Mountainous Soil. The Sub-Mountainous soils are dark brown in color due to high organic carbon content, whereas the mountainous soil is brown in color. The soil texture in general varies from loam to sandy loam, except in the low valley areas, located southwest of Mandi town being heavy textured (CGWB, 2013).

1.5 SEISMICITY OF THE AREA

The Mandi area is seismically very active and one of the deepest and most active intracontinental subduction zones on Earth, originated due to a collision between the Indian and Eurasian lithospheric plates at the western Himalayan margin. The preliminary fault plane solution derived from moment tensor inversion suggests a thrust fault (Vishwa et al, 2010).

In addition to the above, it is mention that the occurrence of earthquakes in the region is attributed mainly to the tectonic settings of Main Boundary Thrust (MBT), Main Central Thrust (MCT) and several local faults and geological demarcated lineaments. Mandi falls in seismic zone IV, which has been classified as high damage risk zone MSK VIII (Source: BMPTC Earthquake Hazard Map, HPSDMA website).

Three epicenters have been recorded in Mandi so far. The locations of the epicenters are given in the Geotechnical Characteristics and Natural hazards map below in **Figure 1.3** (Source: Natural Hazard Map of Mandi District, Himachal Pradesh, Geo Data Division, GSI, Chandigarh prepared from Seismotectonic Atlas, 1995).

As per the data of National Centre for Seismology (NCS), an earthquake of magnitude M 5.8 occurred on 5th August 2023, with its epicenter in Hindu Kush Region, Afghanistan. The earthquake is widely felt in Himachal Pradesh, Jammu and Delhi-NCR region. Aftershocks events also occurred on 05th August and 06th August 2023. (NCS, Report No.: NCS-NSN-EPG-05)

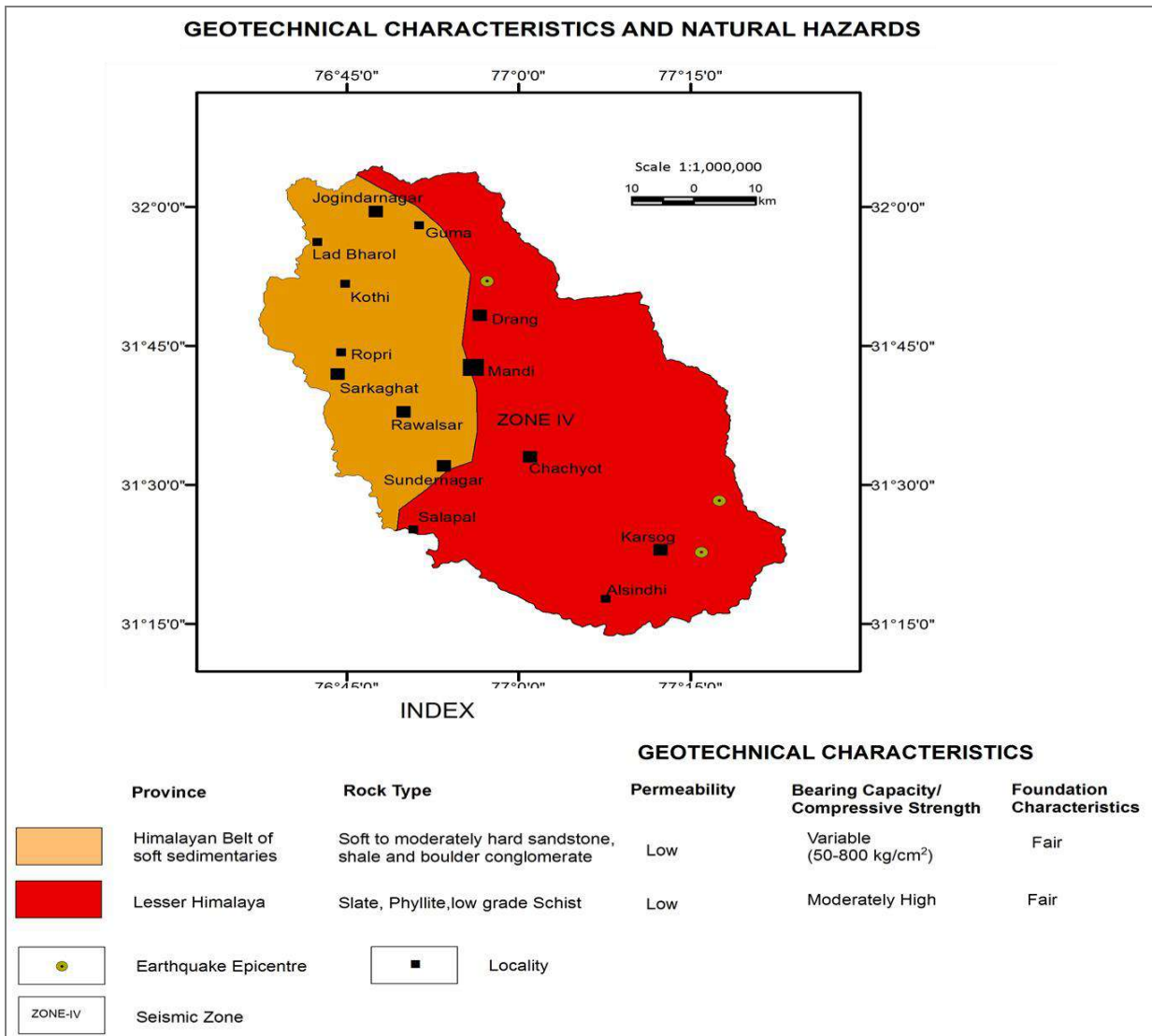

Figure 1.3: Natural Hazard Map of Mandi District, Himachal Pradesh, showing the epicenter locations as marked from Seismotectonic Atlas, 1995 (Source: Geo-data Division, GSI Chandigarh)

1.6 FLORA AND FAUNA

Mandi district of Himachal Pradesh has a rich floristic diversity due to its geographical location, wide-ranging altitude (500 m to over 4000 m) and climatic conditions varying from subtropical to alpine types. The vegetation of Mandi district is characterized by sub-tropical to temperate forests. The area has number of protected forests and open mixed jungles. The flora of the area constitutes varieties of trees and shrubs such as Chir (*Pinus longifolia*), Oak (*Quercus incana*), Deodar (*Cedrus deodara*), Shisham (*Dalbergia sissoo*), Tooni (*Cedrella toona*) and willow (*Salix* sp.), Bamboo (*Bambusa* spp.) and Peepal (*Ficus religiosa*). The shrubs like Pigeon berry (*Duranta plumier*), Mehndi (*Dodonaea viscosa*), wild rose (*Rosa* spp.) and Bhang (*Cannabis sativa*). The main agricultural crops of the area comprise paddy, maize, wheat and barley. The fauna found in region includes musk deer, blue mountain sheep, mongoose, black bear, brown bear, panther or leopard, wild boar, deer, sambar. Variety of birds are found in the area include peacock, western tragopan, monal, ring dove, spotted dove, shikara, parrot, tawny eagle, pigeon, griffon vulture, tits, nutcracker, pies and woodpecker etc.

1.7 ACKNOWLEDGEMENT

The authors are highly grateful to Dr. Joyesh Bagchi, Dy. DG, GSI, SU: PH & HP for giving the opportunity to carry out this investigation and extending all the administrative support. The authors extend their sincere gratitude to Sh. Prashant Ilamkar, Director, Engineering Geology Division for providing technical guidance, under whose able supervision the project was executed and successfully completed. The authors are thankful for his useful suggestions, constant guidance, support, keen interest, critical review, and also discussions and encouragement during the course of fieldwork and report writing. The authors also express their sincere thanks to Shri Arindam Chaudhary, Deputy Commissioner, Mandi, Himachal Pradesh for providing the logistic and administrative support. The authors also extend thanks to authorities of DDMA, Mandi for administrative support. The authors also extend gratitude towards Shri Manish, Senior Architect for his support during survey work and Shri Sher Singh, Sr. Draftsman, HPPWD for his help in preparation of map. The authors also extend gratitude towards NIT Hamirpur, local administration and authorities for their support and cooperation during the entire course of fieldwork.

1.8 PREVIOUS WORK AND BACKGROUND HISTORY

Mc. Mahon (1883 and 1885) undertook geological traverses in parts of the area and gave an account of the geology of the area in the Records of the Geological Survey of India. Setti (1961) was the first to carry out systematic mapping in Mandi and Sundernagar area. Srikantia (1962-1976) mapped parts of

Mandi and Sundernagar area and gave detailed lithostratigraphic classification of Shali Formation. Srikantia and Sharma (1976) grouped the Volcanics exposed at Mandi-Sundernagar and Darla-Tattapani area in the Shali belt as Mandi-Darla Volcanics and traced the Volcanics and associated rocks along the Shali belt. Singh & Singh (2021-22) carried out systemic mapping of the area to study the tectonic setting, geochemistry and geochronological characterization.

GSI has been carrying out landslide studies for many decades. The studies include landslide hazard zonation, landslide susceptibility mapping, site specific studies, geo geoenvironmental studies aspects and other short term studies pertaining to Engineering Geology Division. Srivastava K.N. (1967-68) had investigated the subsidence of the hill slopes while carrying out field work near Joginder Nagar power house. Srikantia and Bhargava (1971) carried out geological investigations after the formation of sink hole at Runjh in Mandi District. The sink-hole was located in the basic volcanic rocks of the Shali structural belt. Singh and Kulshrestha (2001) carried out the Geo-environmental appraisal of Mandi district.

Vedakkedath and Biswal (2015-16) carried out the Landslide susceptibility mapping of the Mandi district on a scale of 1: 50,000 using multi temporal satellite imageries and extensive field work to classify the area into probable susceptibility zones. They have stated that landslides have been initiated due to anthropogenic activities like extensive cutting of the slope for the widening of road, toe erosion by Beas River and its tributaries, and slope failure due to oversaturation during heavy monsoon periods. The landslides were found to be generally active alongside the road, when aligned through the Mandi Thrust zone as observed on NH-21 near Sundernagar and on the State Highway between Mandi and Jogindernagar. A few instance of land subsidence due to the solution activity of salt-grit at Runsh village have been reported, which warrant curbing of settlement activities around the affected area. The Landslide susceptibility has also been correlated to the drainage network of the area.

1.9 PRESENT WORK

The authors of this report under able guidance Shri P.T Ilamkar, Director, Engineering Geology Division, carried out the first phase of the study of landslide of Tarna hill on Mangwai road and Kanganidhar on Mandi-Rewalsar Road. The authors concluded that the slides were debris slides, activated due to heavy precipitation and vibrations produced by vehicular movement on the road at the toe of the slide. The first information report of the slide had been prepared by incorporating details on their morphology, geology and causative factors and is attached as Annexure –II.

The detailed field work was carried out from 26th September to 13th October, 2023. During the present investigation, a total of two number of landslides were studied on a scale of 1:1000. For conducting the detailed studies of Tarna hill landslide located near the old Suketi *Khud* Bridge with its toe terminating at the Mangwai road, an area of 0.11 sq. km was geologically mapped on a contour plan prepared using the Total Station. The Kanganidhar Landslide, located along the National Highway (Mandi Rewalsar Road), was also studied in detail as per the request of DC, Mandi. An area of 0.098 sq km was covered during the investigation. A detailed geological map on the 1:1000 scale, one longitudinal section, and one geological cross-section for each of the landslides were generated during the course of the investigation. The total five undisturbed soil samples (three from Tarna Hill and two from Kanganidhar) have been collected from the study area for the determination of relevant geotechnical properties. The nature and quantum of work carried out and the details of the officers involved in the investigation have been listed in Table 1 (A) and (B) respectively.

Table 01 (A): Nature of work		Slide Description	Quantum of work
1. DM (1:1000 scale)		Tarna Hill Kanganidhar Landslide	- 0.110 Sq. Km. - 0.098 Sq. Km
2. Geotechnical analysis (a) Undisturbed soil samples		Tarna Hill Kanganidhar Landslide	- 03 Nos - 02 Nos.
4. Geological profile sections		Tarna Hill Kanganidhar Landslide	- 01 Nos. - 01 Nos.
Table 01 (B): Details of Field officers			
<i>Sl No.</i>	<i>Name</i>	<i>Designation</i>	<i>Field Days</i>
1.	Sh. P.T. Ilamkar	Director	2
2.	Smt Shreyasi Mahapatra	Senior Geologist	18
3.	Ms. Tripti Baba	Senior Geologist	18

CHAPTER-2

GEOLOGY

2.0 REGIONAL GEOLOGY OF THE AREA

The geological composition of the region is characterized by rocks of varying ages, from the Paleoproterozoic to the Holocene. The Paleoproterozoic era is represented by the Kullu, Vaikrita, and Sunder Nagar Groups. The Mesoproterozoic period is embodied by the Shali Group, while the Neoproterozoic period includes the Manjir, Katarigali, and Guma Formations. The Paleogene and Neogene periods are represented by the Sirmaur and Siwalik Groups respectively. The Holocene era is represented by the Newer Alluvium Group.

The area has experienced a series of deformations, leading to the formation of NW-SE trending regional folds resulting in the repetition of various lithounits. The area is marked by numerous regional thrusts and faults, including the Palampur thrust. In some places, these folds are disrupted by thrusts or faults.

Most of the slide incidences in the area have been recorded in the basalt and quartz arenite from the Mandi Volcanics within the Sundernagar Group. The area is covered by a thick overburden of moderately compact soil and paleo-debris material, with an approximate thickness of 3-5 meters

The Geological Map of the area and the landslide location under study is given in **Figure 2.0**.

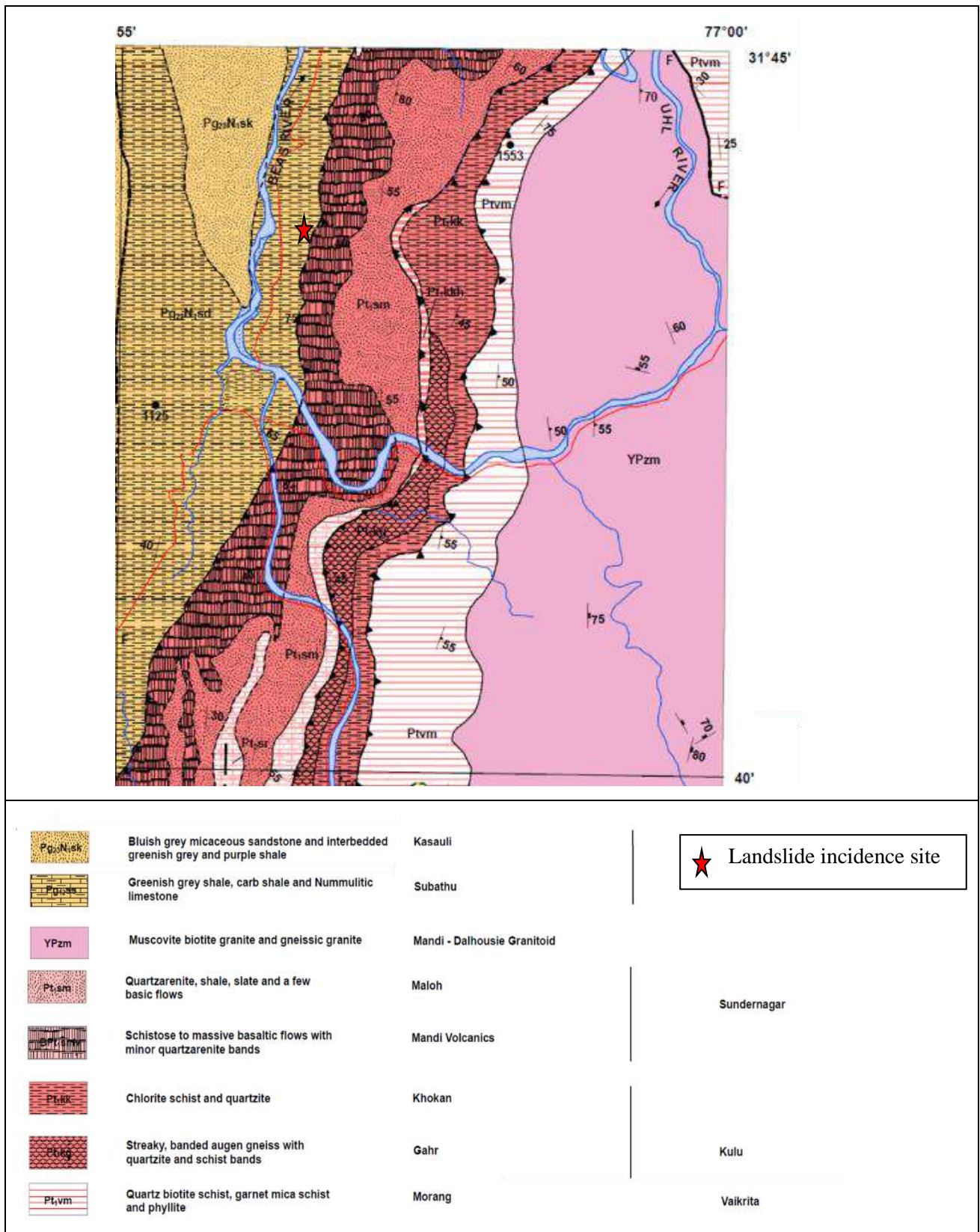

Figure 2.0: Regional geological map of study area

CHAPTER-3

METHODOLOGY

3.0 METHODOLOGY

The methodology adopted during the course of investigation include the pre-field / HQ based studies, active field work and the analysis and interpretation of data. The pre-field/ headquarter study comprises collation, collection of available literature and data pertaining to the area of interest. All the information gathered were put to use during the course of the present study. The affected zone of Tarna and Kanganidhar landslides/slope failures were delineated from the open source Google Earth Imagery. The study of the entire landslide zone was undertaken to understand the temporal variation and to attempt for the possible cause of the slide zones, if any.

In order to study the morphometry, lithology and structure of the three slide zone, large scale geological mapping on 1:1000 scale was carried out in associated with the Survey Consultants deployed by DDMA. The mapping was carried out using TOPCON total station survey equipment (**Figure 3.0**). During the course of the detailed geological mapping, observations regarding slope forming material (lithology/debris etc.) and orientation of the different discontinuities have been recorded and mapped in detailed (**Plate Nos I**). A total of 5 nos. of samples were collected from the study area and submitted for geotechnical parameters to the office of DDMA, Mandi which were further sent by them for GT analysis to Department of Civil Engineering, National Institute of Technology (NIT), Hamirpur, HP. (Annexures- III). The results of geotechnical parameters received from NIT Hamirpur through DDMA has been incorporated and interpreted in the report.

The structural data of the exposed rock mass around the slide zones were collected for Rock Mass Rating (RMR) and Slope Mass Rating (SMR) studies. The data collected during extensive field work was also plotted to generate a detailed geological map as a part of the post-field inputs. The topographical/geological map was generated using AutoCAD software and a section was each drawn over the detailed geological map for each slide zone.

Kinematic analysis has been carried out in the exposed rock mass to apprehend the failure mechanism and possible mode of failures, and also to suggest suitable remedial measures.



Figure 3.0: Photograph showing topographical and detailed geological mapping of landslide (slope failure affected sites) using advanced Total Station Equipment (TOPCON) during extensive field work at **a)**Tarna Hill landslide **b)** Kanganidhar landslide

3.1. Rock Mass Rating (RMR):

The Rock Mass Classification system, also known as the Rock Mass Rating (RMR) system, is a system developed by Bieniawski in 1989. This system is a rated base system that combines the most significant geological parameters and represents them through an overall comprehensive index of rock mass quality. This index is widely used for design and construction purposes in various fields such as tunnels, mines, foundations, and rocky slope stability assessments.

The process of Rock Mass Classification involves grouping a rock mass into classes based on defined relationships and assigning a unique description (or number) to it. This is done based on similar properties or characteristics, allowing for the prediction of the behaviour of the rock mass.

To obtain the basic RMR value (RMR_{basic}), the system requires five input parameters.

1. Uniaxial compressive strength (UCS) of intact rock mass.
2. Rock quality designation (RQD)
3. Spacing of discontinuities
4. Condition of discontinuities, and
5. Groundwater conditions

Using the RMR_{basic} value, a rock mass is classified into five classes. These classes range from 0 to 100, with an equal class interval value of 20 as depicted in **Table 3.1**. As the RMR value increases, the shear strength of the rock mass also increases. This means that a rock mass with a higher RMR value is likely to have greater resistance to shearing forces.

Table 3.1: Rock mass classification after Z. T. Bieniawski 1989.

RMR Value	Rock Quality
100-81	Very Good
80-61	Good
60-41	Fair
40-21	Poor
20-0	Very Poor

3.1.1. UNIAXIAL COMPRESSIVE STRENGTH (UCS) OF ROCK MASS

Schmidt Hammer, also known as a Swiss Hammer or a Rebound Hammer, is a tool used to measure the elastic properties or strength of concrete or rock. The primary measurements it provides are surface hardness and penetration resistance. The hammer works by measuring the rebound of a spring-loaded mass that impacts against the surface of the sample.

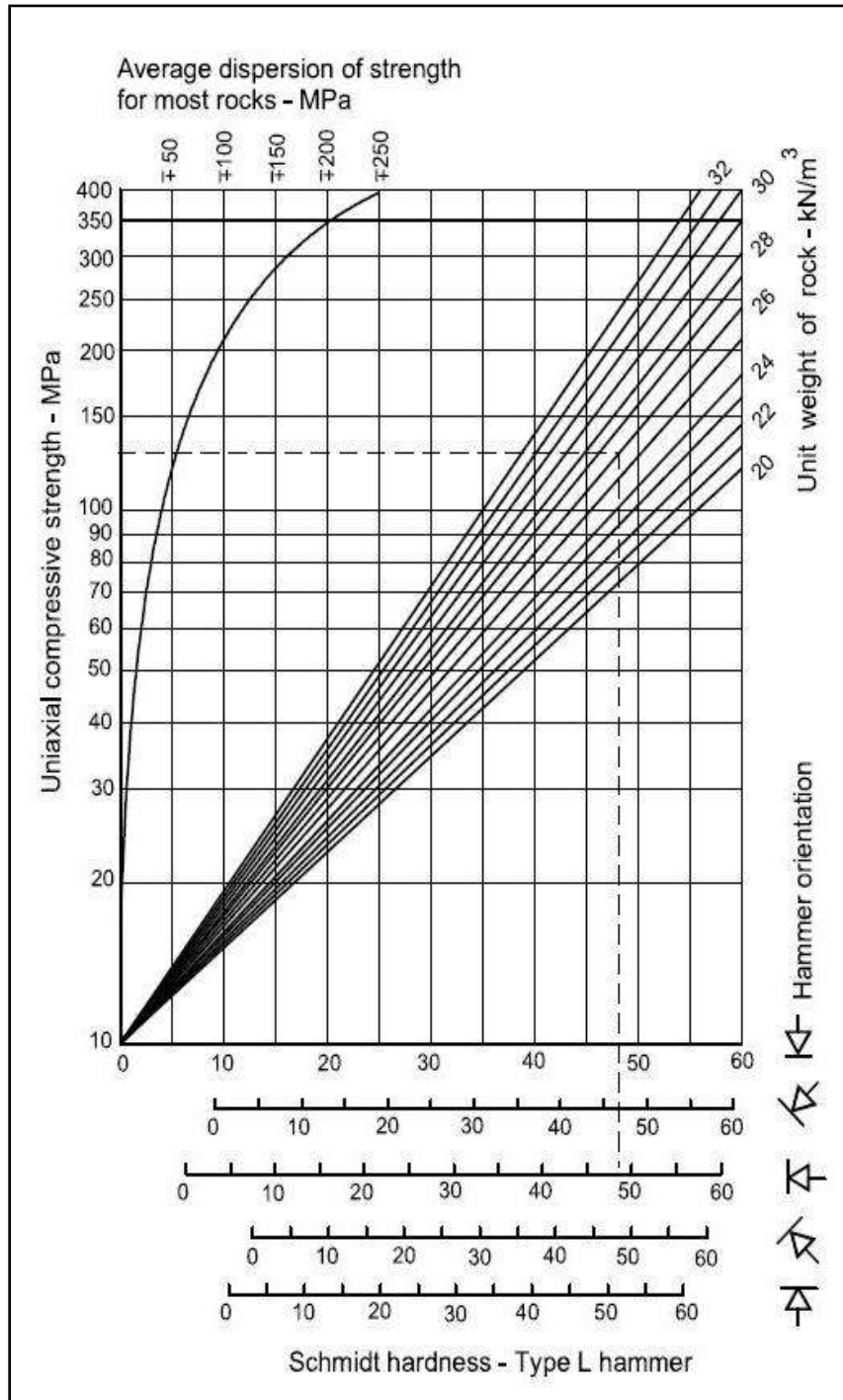

Figure 3.1: Standard Chart for converting rebound of Schmidt hammer to know UCS value (Deere and Miller, 1966)

The test hammer hits the surface with a defined energy, and the rebound is dependent on the hardness of the surface. This rebound is measured by the test equipment. With the help of a conversion chart, the rebound value can be used to determine the compressive strength.

When performing the test, the hammer should be held at a right angle to the surface, which should be flat and smooth. The standard chart provided by Deere and Miller in 1966 is used to convert the rebound value obtained from the Schmidt Hammer into the uniaxial compressive strength (UCS) (**Figure 3.1**). This is done by following the diagonal of the rock mass of known density.

3.1.2. Determination of Rock Quality Designate (RQD):

RQD stands for the Rock Quality Designation, which is a measure of the degree of fracturing of a rock mass. Its primary purpose is to represent the quality of the in-situ rock mass. The RQD is determined during the geological mapping of the slide zone using the volumetric joint count (J_v) approach, as suggested by A. Palmstrom in 1982.

This method takes into account the number of discontinuities per unit volume. The formula for calculating RQD using this approach is provided in the formula as mentioned below.

$$RQD = 115 - 3.3 \times J_v \tag{1}$$

The J_v is the volumetric joint count which is the sum of number of joints per unit length for all joint sets. The rock mass quality classification given by Deere et.al 1967 is shown in **Table 3.2**

Table 3.2: Rock mass quality classification according to RQD (Deere et al, 1967).

RQD	Rock Mass Quality
<25	Very poor
25-50	Poor
50-75	Fair
75-90	Good
99-100	Excellent

3.2. Slope Mass Rating (SMR):

SMR values are computed using Romana's (1985) technique to evaluate the stability of potentially unstable rock slopes and recommend effective protective measures. SMR is derived from the Rock Mass Rating (RMR) values or RMR_{basic} of Bieniawski (1989). To assess slope instability, adjustment factors are introduced to account for discontinuity and slope orientations, failure modes (such as planar, wedge, and toppling), and slope excavation methods. The quality of the rock mass is assessed based on the RMR index.

Based on the findings, slopes are classified into different instability classes with associated risks. For rocky slopes, their stability depends on several key factors as below:

1. Height and angle of slopes
2. Disposition of geological discontinuities

3. Angle of friction of the material
4. Cohesion of the material, and
5. Effect of water pressure

Table 3.3a: SMR classes (Romana 1985).

Type of failure		Very favorabl	Favorable	Normal	Unfavorable	Very unfavorable	
P	A	>30°	30-20°	20-10°	10-5°	<5°	
T							$ \alpha_j - \alpha_s $
W							$ \alpha_j - \alpha_s - 180 $
P/T/W	F ₁	0.15	0.40	0.70	0.85	1.00	
P/W	B	<20°	20-30°	30-35°	35-45°	>45°	
T							$ \beta_j $ or $ \beta_i $
P/W	F ₂	0.15	0.40	0.70	0.85	1.00	
T							1.00
P	C	>10°	10-0°	0°	0-(-10°)	<(-10°)	
W							$\beta_j - \beta_s$
T							$\beta_i - \beta_s$
P/T/W	F ₃	0	-6	-25	-50	-60	
Excavation method (F₄)							
Natural slope		+15	Blasting or mechanical		0		
Presplitting		+10	Deficient blasting		-8		
Smooth blasting		+8					
P=Planner failure, E=Wedge failure, T=Toppling failure, α_j =dip direction of discontinuity, α_s =direction of slope, α_i =trend of intersection line of plane, β_j =dip amount of discontinuity, β_s =dip amount slope, β_i =plunge of intersection line							

Table 3.3b: SMR classes (Romana 1985).

Class No.	V	IV	III	II	I
SMR Value	0-20	21-40	41-60	61-80	81- 100
Description	Very Bad	Bad	Normal	Good	Very Good
Stability	Completely Unstable	Unstable	Partially Unstable	Stable	Completely Stable
Probable type of Failure	Big planar or Rotational	Planar or big wedge	Planar or many wedges	Blocks	None

The SMR classification system is utilized to assess the stability of potentially-failing rock slopes and recommend effective protection measures. It categorizes slopes into different classes based on their susceptibility to instability. The system is based on the RMR system and incorporates adjustment factors that consider the orientation of discontinuities relative to slope parameters. Romana proposed

the SMR system in 1985 and updated it in 2003 by introducing four adjustment factors (F1, F2, F3, and F4) and RMR_{basic} , which takes into account the relationship between slopes, discontinuities, and the method of slope excavation. It is obtained using equation (2):

$$SMR = RMR_{basic} + (F_1 \times F_2 \times F_3) + F_4 \quad (2)$$

Where:

- RMR_{basic} is the basic RMR index resulting from Bieniawski's rock mass classification;
- F_1 depends on the parallelism between discontinuity dip direction (α_j), and slope dip, (α_s)
- F_2 is related to the probability of discontinuity shear strength (Romana, 1993) and depends on the discontinuity dip, $B=\beta_j$, in the case of planar failure. For toppling failure, this parameter adopts the value 1.0.
- F_3 depends on the relationship between slope (β_s) and discontinuity (β_j), dips.
- F_4 is a correction factor that depends on the excavation method

SMR class with its description as proposed by Romana 1985 is enumerated in Tables 3.3 9(a) and (b).

3.3. Factor of Safety (FoS):

Slope stability analysis plays a crucial role in the study of landslides by determining the likelihood of slope failures and the maximum stress that a hillslope can handle before collapsing. The main objective is to assess the potential failure mechanism for slope movement, understand how the slope responds to different triggering mechanisms, and design safe, reliable, and cost-effective slopes. This analysis takes into account geological, geotechnical, and environmental factors to evaluate the equilibrium conditions of a slope. In this study, we compared the factor of safety (FoS) and critical slip surfaces obtained through two different methods: The Limit Equilibrium Method (LEM) and the Finite Element Method (FEM) using the Midas SoilWorks software. Additionally, we incorporated field observations to establish a correlation with the obtained results. The Midas SoilWorks software, developed by Midas, is a specialized tool for two-dimensional analysis that efficiently addresses complex geotechnical problems, saving time and effort in the design process. This software provides a user-friendly environment and generates reliable results that align with practical design considerations. It integrates both LEM and FEM analyses, making it a dependable software for comparing results obtained from these two methods. The Bishop and Spencer method was used for the LEM analysis. The Mohr-Coulomb model is utilized in both the LEM and FEM based analyses. This combination of methods and models enhances the software's reliability, thereby enabling a comprehensive evaluation of slope stability.

The parameters considered for modeling includes:

1. Profile section prepared in AutoCAD and imported into SoilWorks for the analysis.
2. The entry point and exit point of probable failure surface along the section/profile.
3. The strength parameters of the material (soil and rock) like cohesion (c), angle of internal friction (ϕ), modulus of elasticity (E) and Poisson's ratio (μ).

3.3.1. Limit Equilibrium Method:

The limit equilibrium concept is widely utilized in traditional stability analysis. This conventional approach assumes a continuous rupture or slip surface along which the soil behaves as a rigid plastic material that satisfies the Mohr-Coulomb failure criterion. By considering stresses within the soil mass, a solution can be obtained (K.T Law and P Lumb, 1978). The limit equilibrium method is considered the predominant approach for analyzing slope stability, applicable to both two-dimensional and three-dimensional scenarios. Among the various techniques, the methods of slices are extensively used. These include the ordinary method of slices (Fellenius), as well as the Bishop simplified, Spencer, and Morgenstern-Price methods. For this study, we employed the Bishop and Spencer methods to conduct the analysis. It is well-acknowledged that the slices technique poses a statically indeterminate problem that is resolved by assuming an internal force distribution. Consequently, the results obtained from specific methods may vary due to the different assumptions employed.

3.3.2. Bishop Method:

The Bishop method, also known as Bishop's Simplified Method, is a simplified approach used in Geotechnical engineering to assess the stability of slopes. It was developed by Professor Alan Wilfred Bishop and published in 1955. Grounded on the principle of limit equilibrium, the Bishop method assumes that a slope will fail when the driving forces exceed the resisting forces. It offers a simplified framework for evaluating slope stability by considering the forces acting on a potential failure surface.

In contrast to the Swedish Method, the Bishop method takes into account the inter-slice forces. This method considers the landslide base as a circular arc shape. Firstly, the slope's geometry, the center point of the circular arc, and the shear position need to be determined. The Bishop method is widely used in slope stability analysis due to its simple yet accurate safety factor calculations. It is particularly effective in automatically identifying critical failure planes to determine the minimum safety factor value.

The position of the center can be adjusted to increase the safety factor of a critical circle. When water

or soil becomes saturated, it generates an upward lifting force as the normal force on the base of the slice reduces. Hence, the stability analysis of the slope requires considering the effective stress condition. The Bishop method determines the normal force (P) on the base of the slice by analyzing the forces acting on it, which can be categorized as the downward force (W) and the resultant force in the horizontal direction on the vertical limit of the slice.

Factor of safety serves as a reflection of the slope's conditions in numerous studies regarding slope stability analysis. The value of the safety factor (SF) holds significant importance in determining the significance of slope stability. The Bishop model is given in **Figure 3.2**.

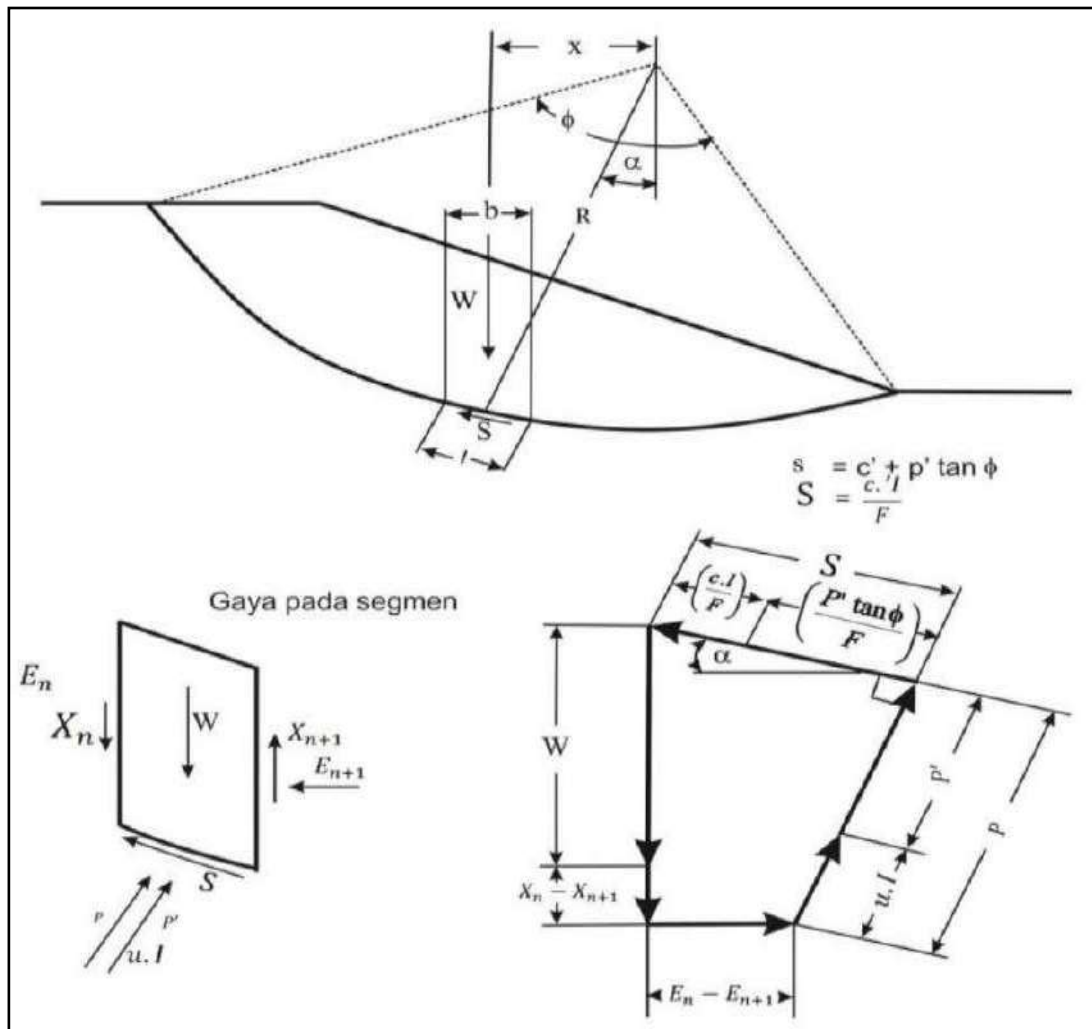

Figure3.2: Forces working on the slices (simplified Bishop method).

3.3.3. Spencer Method:

The Spencer method, created by geotechnical engineer Edwin Spencer, is a highly rigorous approach in analyzing slope stability. It effectively considers both force and moment equilibrium of the failure mass, allowing for more precise calculations of the Factor of Safety (FoS). Unlike other methods of slices, the Spencer method takes into account the interslice normal and shear forces by replacing them with an equivalent resultant force positioned at the midpoint of a slice base. By utilizing principles of equilibrium and limit analysis, this method offers a comprehensive evaluation of slope stability, making it particularly useful for slopes with complex geometry, multiple soil layers, and varying soil properties. The spencer model is given in **Figure 3.3**.

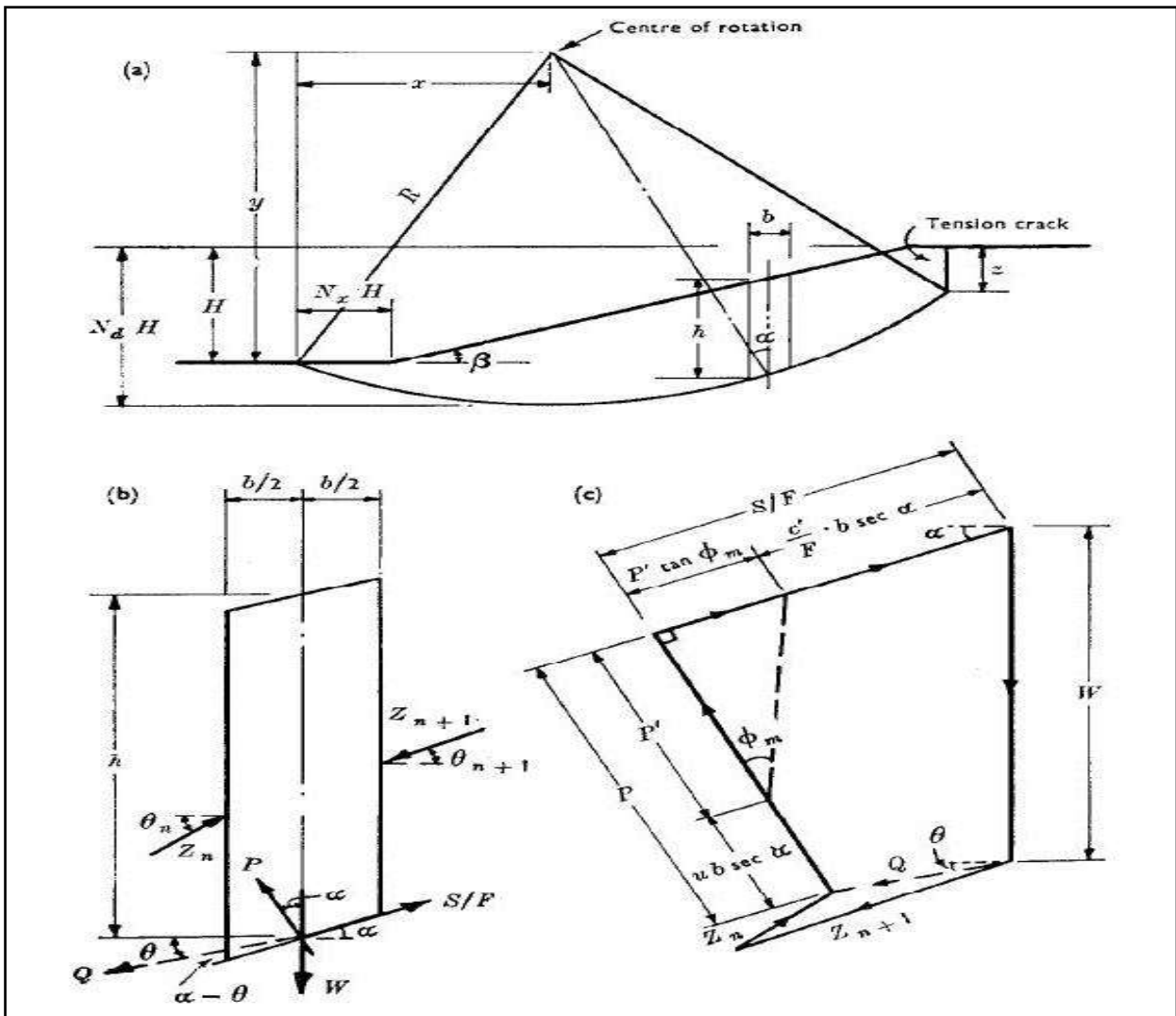

Figure 3.3: Dimension of slip surface and Forces working on the slices (Spencer method).

In the early stages of developing limit equilibrium methods of slices, the slip surface is assumed to be cylindrical. The earth mass within this slip surface is divided into several vertical slices, and in each slice calculation, the resultant forces and sum of moments must be equal to zero. However, the outcome of each method of slices is dependent upon several factors including the definition of Factor of Safety and the assumptions made regarding the interslice forces between the vertical slices. The Spencer method essentially serves as a modified and extended version of the Bishop's simplified method.

3.3.4. Finite Element Method:

The Finite Element Method (FEM) is a numerical technique for assessing slope stability. It enables the analysis of intricate geotechnical issues by dividing the problem domain into smaller elements and forming a mesh through interconnected nodes. By solving the governing equations for each element, considering the specified boundary conditions and material properties, the FEM facilitates a comprehensive evaluation of slope stability, among other complex geotechnical problems.

In the context of slope stability assessment, FEM enables the comprehensive evaluation of critical factors including stress distribution, deformation, and potential failure mechanisms within the slope. By dividing the slope into finite elements, the FEM accommodates variations in soil properties and slope geometry, making it well-suited for analyzing heterogeneous and irregular slope profiles. The FEM facilitates a detailed analysis of slope behavior considering elements such as non-linear soil behavior, pore water pressure, and complex geometries. As a result, it provides a versatile and powerful tool for assessing slope stability and gaining insights into the interplay between soil, water, and structural components in a slope system.

3.3.5. Strength Reduction Method:

Strength Reduction Method (SRM) is used for the analysis. The SRM was used for slope stability analysis as early as 1975 by Zienkiewicz et al. A common definition of factor of safety for a slope is considered to be the ratio of actual shear strength to the lowest shear strength of a soil that is required to maintain the slope in equilibrium (Chowdhury, 1978). The available shear strength depends on the properties of the soil, which are measured from laboratory and field tests. In SRM, the shear strength of the soil is reduced to trigger the slope into failure. The resulting strength reduction factor when the collapse occurs is designated to be the factor of safety for the slope.

The primary advantage of the SRM is that the critical slip surface is found automatically from the shear strain, which increases as the shear strength decreases. It can assess the stability of slopes more realistically

by considering the progressive failure process and provides valuable insights into the critical failure mechanisms. However, the SRM suffers from the important limitation of being unable to locate other “slip” surfaces. In the SRM, the FOS is defined as the factor by which the original shear strength parameters must be divided to bring the slope to the point of failure.

3.3.6 Circular Failure Chart (CFC)

The circular failure charts are used to find an essential combination of slide surface and tension crack for a wide range of slope geometries and groundwater conditions. The circular Failure Chart method is the easiest method to analyze and find out the Factor of Safety. This method is a semi-empirical approach method and required minimum laboratory testing. Its required parameters are density, shear strength, height, and steepness of the cut slope. These parameters will give the safety factor of the particular slope after plotting the corresponding circular failure chart. Circular failure happens when the small particles in soil or completely exposed rock mass are small compared to the slope's size and are not interlocked due to their shape.

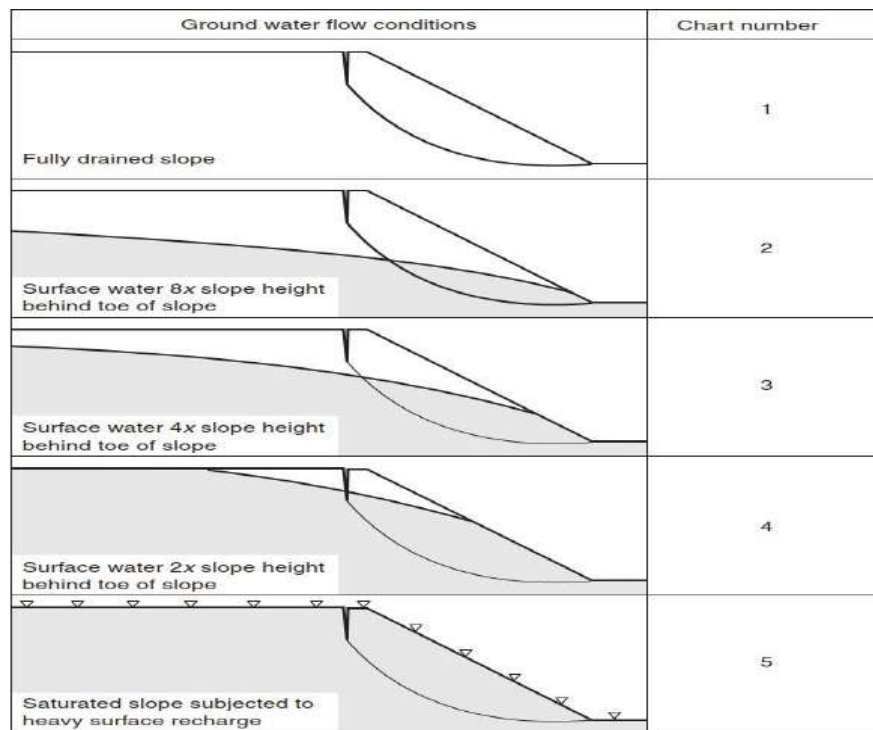

Figure 3.3 (a). Groundwater conditions chart.

In the Circular Failure Chart (CFC), several groundwater flow schemes are given to adjust the pore water pressure in the subsurface and stresses due to water present in tension fractures. For that purpose, **Figure 3.3 (a)** depicts a set of possible field conditions that have been chosen and shown in a combined manner. To

obtain the FOS, follow the techniques explained below and depicted in **Figures 3.3(b)** and **3.3(c)**. The first step is to choose rock strength parameters that apply to the slope's material. Then determine the groundwater conditions on the slope and select the chart closest to these conditions using **Figure 3.3(a)**. The next step is to compute the dimensionless ratio with the formula below:

$$\frac{c}{\gamma H \tan \phi} \quad (3)$$

Furthermore, find this value on the chart's outer circular scale. The value found to the junction with the curve corresponds to the slope angle and follows the radial line. The last step is to find the suitable value of $c/(HFS)$ or $\tan \phi/FS$, whichever is more convenient and calculate the FOS.

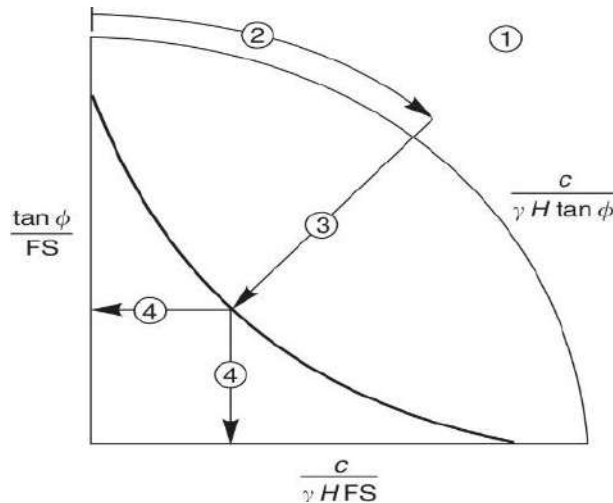

Figure 3.3(b) Calculation of FOS from CFC chart

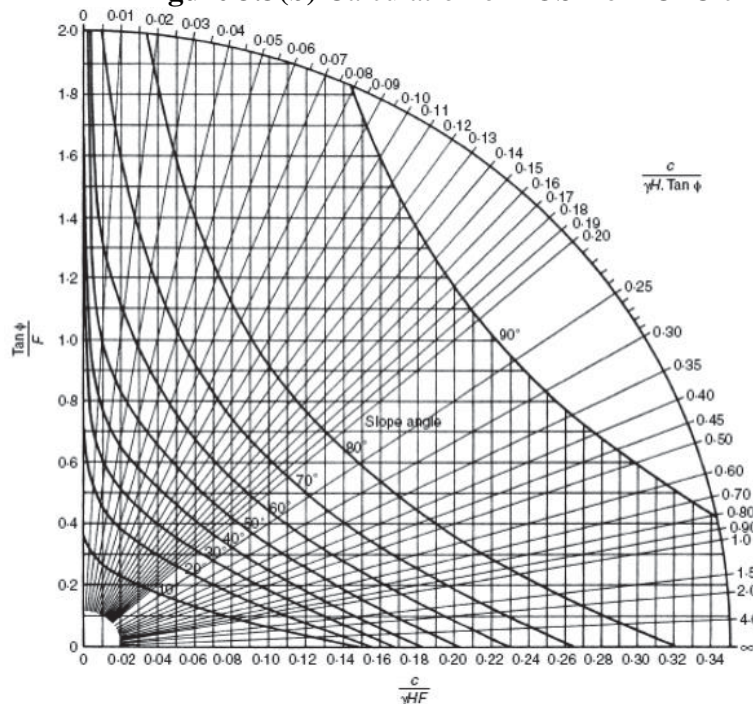

Figure 3.3(c). Model CFC chart

CHAPTER-4

TARNA HIL LANDSLIDE

4.0 Introduction:

Detailed geological mapping of Tarna landslide has been carried out covering an area of 0.11sq km on 1:1000 scale. The slide is located on the left bank of Suketi *Khud* (latitude 31° 42' 19" N and longitude 76° 55' 59" E) on Survey of India Toposheet No.53A/14. It lies nearly 1.8 Km southwest from Mandi town, Mandi District, Himachal Pradesh.

The tragic event showed first signs of its occurrence during the first week of August 2023. The situation was further exacerbated by the continuous rains on the 12th and 13th of August following which the hillside gave way on the 14th of August, causing one building to collapse and causing significant damage to several others. However, due to the quick response of the district authorities, there were no reported casualties. However, the slide destroyed the pathway connecting the houses and damaged the drainage pipes and channels (**Figure 4.1**). Additionally, the event highlighted the need for immediate preventive measures as diagonal cracks were observed on the walls and floors of adjacent building, indicating a potential expansion of the slide (**Figure 4.2**). The incidence underscores the importance of monitoring weather conditions, especially in areas prone to landslides, and the need for prompt action in such situations to prevent loss of life and property.

The affected houses appeared to be in an unstable condition, with tension cracks identified in the crown portion of the slide. These cracks, which trended north-northeast (N 80°), were filled with clay and covered with impervious plastic sheets to provide a temporary solution (**Figure 4.3**).

The slide also caused uprooting of electric poles and trees, further highlighting the severity of the incident (**Figure 4.4**). The water from domestic drains has been diverted to the nearest nala to prevent further water saturation and potential exacerbation of the slide.

The slide's morphometry, reveals it to be a debris slide, a type of rotational failure. This type of landslide is typically triggered by slope saturation due to heavy rain, which weakens the slope debris and leads to a rotational failure. **Figure 4.5** shows the morphometry of the slide.



Figure 4.1 Slide leading to collapsed pathway, damaged the drainage pipes and channels during slide



Figure 4.2 Diagonal cracks observed on the walls and floors of houses

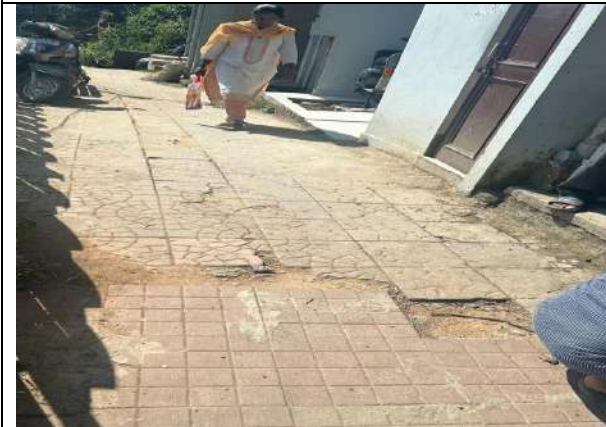

Figure 4.3 Tension cracks trending north-northeast (N 80°E) filled with clay



Figure 4.4 Uprooted electric poles and trees due to slide

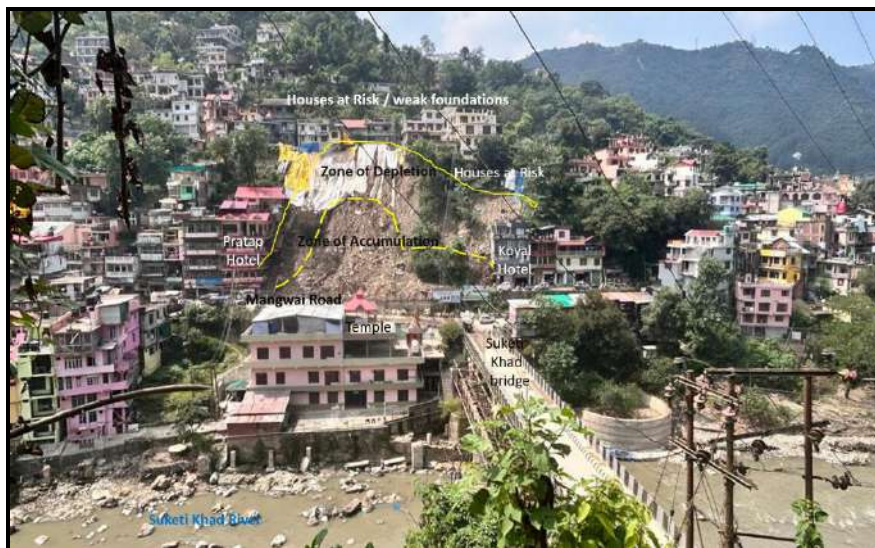

Figure 4.5 : Morphometry of Tarna slide near Suketi *Khud* bridge

The slide is currently active, with its toe terminating in the mid-hill part at the Mangwai Road. The area exhibits generally moderate to steep slopes, which may contribute to the instability of the hillside.

Given these observations, it's clear that the landslide was a significant event with far-reaching implications for the affected area. The landslide area primarily consists of basalt and quartz arenite from the Mandi Volcanics of the Sundernagar Group. The proximity of this area to the Kullu Thrust and Mandi-Sundernagar Thrust likely contributes to the high degree of rock jointing and fracturing.

The weathering index at the toe of the slide ranges from W4 to W5, indicating moderate to severe weathering (ISRM, 1981a). This further suggests the instability of the slope due to weathering processes.

Although no outcrops were observed on the slide area, outcrops were spotted near the left bank of the slide. The presence of joints in the rocks, as observed at the site, could have played a significant role in the landslide. The details of these joints are tabulated in **Table 4.1**, which provides valuable information about the specific geological conditions contributing to the landslide. The elevation of the study area ranges from El ± 900 m to El ± 950 m. The dimensions of the slide were 50 meters high and 120 meters wide, affecting almost 100 meters of the Mangwai road. This has caused significant disruptions in vehicular traffic, highlighting the infrastructure impact of the landslide. The morphometry of the slide is provided in **Figure 4.5**. These diagrams provide a visual representation of the slide's dimensions, location, and impact on the surrounding area, including the Mangwai road.



Figure 4.6 Steep slope exposing loose debris material at crown

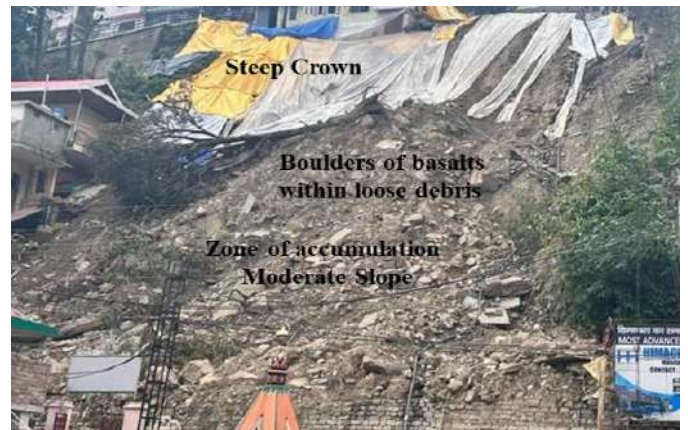

Figure 4.7 Moderate slope and erratic boulders at Belly of slide

The upper limit of the slide is defined by the terraces and connecting pathway for the houses across the slide zone. The active scarp is very steep exposing loose unconsolidated debris material of undifferentiated quaternary deposit with some boulders of basalt and quartz arenite. The active scarp is characterized by

steep slope exposing loose debris material (**Figure 4.6**) followed by moderate slope and erratic boulders along the Mangwai Road (**Figure 4.7**).

The Geological Survey of India (GSI, 2018-2019) has already classified the area as a Moderate landslide susceptibility zone, which aligns with the observed geological conditions.

A detailed geological mapping of the slide zone was carried with the help of the total station. The survey plan for the slide was developed by the surveyor provided by the district administration. The geological map (**Plate-II**) has been prepared by plotting all the morphometric details of the landslide, different lithounits exposed, structural data and different types of overburden materials.

4.1 Morphometric details of the Study Area:

Morphometrically, the landslide is situated on a moderate slope (50° - 60°) on the left bank of the Suketi *Khud*, which flows perennially in an easterly direction. Following the landslide, the slope at the slide scar underwent further modifications and became even steeper, exceeding 70° . The landslide has resulted in the formation of both a depletion zone and an accumulation zone (**Figure 4.8 & Figure 4.9**). The debris mass has detached from the depletion zone and accumulated below the Mangwai Road on the left bank of the Suketi *Khud* in the shape of a triangular heap. As a consequence of the sliding, the slope has also become steeper in the depletion zone and gentler in the accumulation zone.

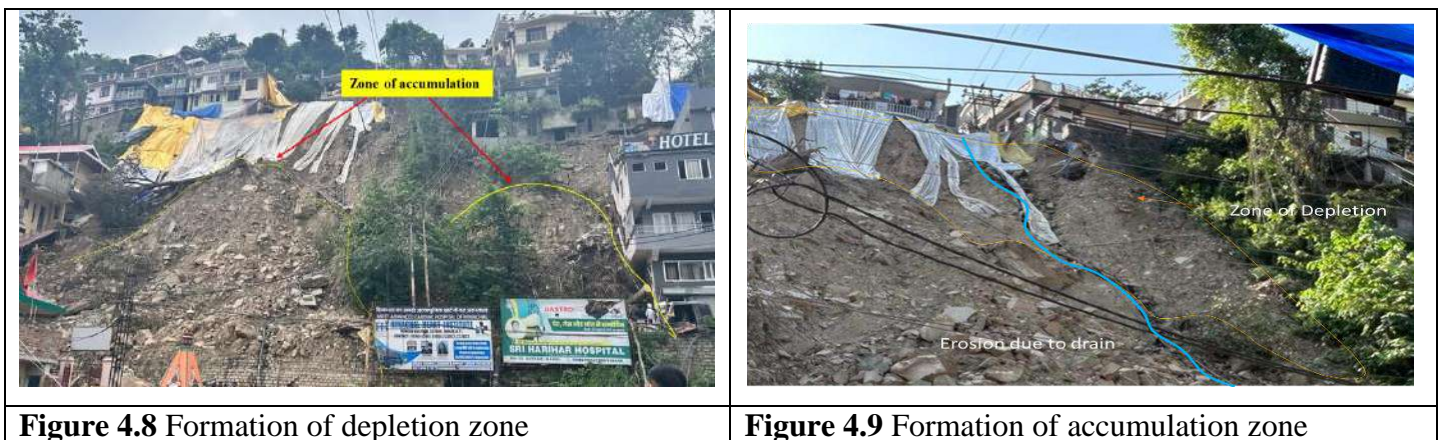

The geological map depicts the active scar of this landslide, which has an irregular shape. At the Mangwai road, the detached debris material forms a typical cone-shaped accumulation. Along the profile of the scar, the perimeter measures approximately 70 m, while the vertical height of the slide is 50 m. Some ground cracks have been observed at the crown (**Figure 4.3**), which could potentially lead to surface failures in the future if left untreated. The morphometry of the slide is illustrated in **Figure 4.5**.

4.1.1 Crown portion:

The slide's crown area, situated above the head region, has elevations ranging from EL ± 937 m to EL ± 943 m. It spans approximately 30 m in length and covers about 0.0043 Sq.km in area. The slope in this flank is characterized by steep angles, ranging from ~60° to ~75° (Figure 4.10). At the highest point, weathered Mandi Volcanics rocks are visible (Figure 4.11). Just below, rock boulders are embedded in loose silty sediment matrix. The overlying material consists mostly of fines with a certain proportion of coarse cobble particles. Some ground cracks have been observed in this section. Evidence of severe gully erosion, along with damage to the road, retaining wall, and the culvert crossing the road, can be seen (Figure 4.12).

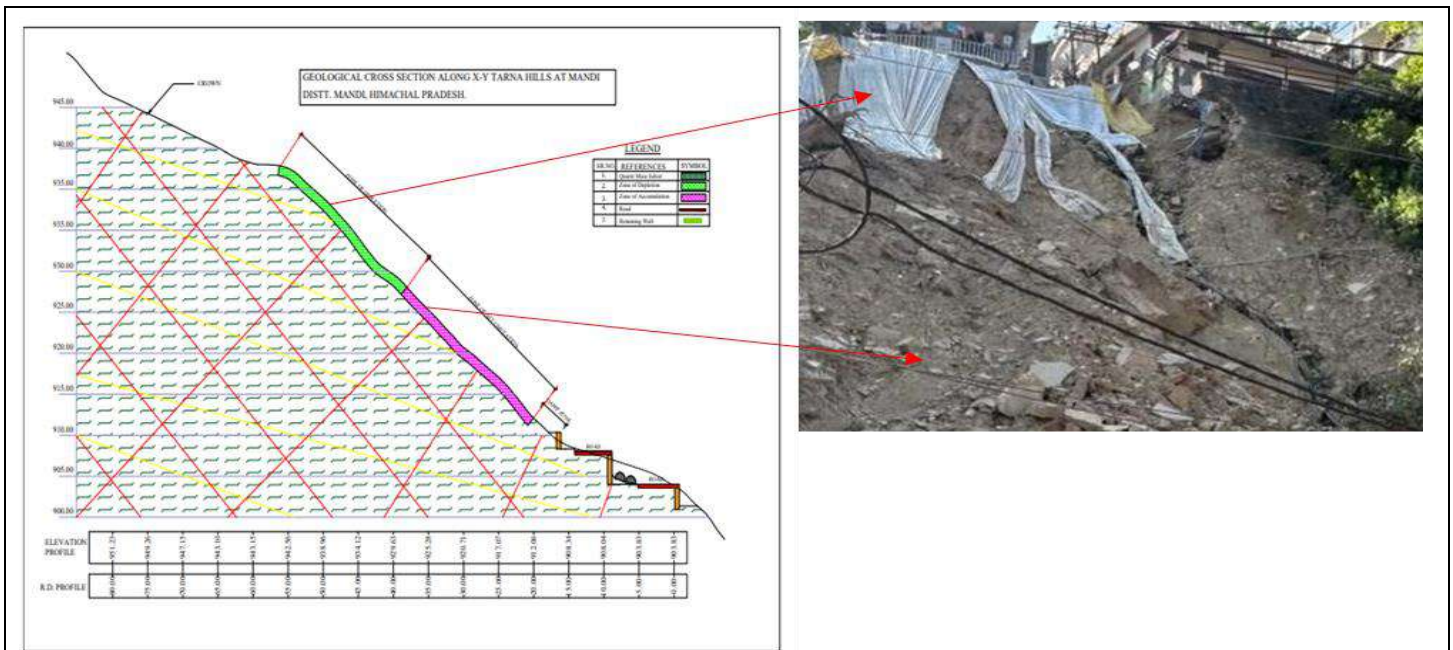

Figure 4.10 Steep slope around crown portion and gentler around the belly



Figure 4.11 Highly weathered rocks of Mandi Volcanics rocks exposed in slide zone

Figure 4.12 Evidence of severe gully erosion, along with damage to the road, retaining wall, and the culvert

4.1.2 Head portion of the Tarna Hill Landslide:

The head portion of the slide is located directly below the crown region. Spanning 32 m in length and 5 m in height, the scar encompasses an area of 0.001 sq. km. The head portion is distinguished by the presence of a 3 m thick overburden between EL \pm 930 m and EL \pm 935 m (Plate-I). The average slopes in this flank maintain a steep gradient of approximately 60°, facing towards the SE direction. This flank is covered in thick debris material consisting of predominantly fine particles with some larger cobble-sized fractions (**Figure 4.13**). The slope features barren land with scattered overhanging boulders ranging from approximately 50 cm to 2.5 m in diameter, embedded within sandy material (**Figure 4.14**).



Figure 4.13 Slope forming materials consisting of thick debris material consisting of fine particles with some larger boulders



Figure 4.13 Barren land with scattered overhanging boulders at the head portion of slide



Figure 4.15 The terraced land situated above crown serving for cultivation and settlement purposes



Figure 4.16 Exposed roots throughout the distressed slope

The exposed rock in this area is of volcanic origin and exhibits varying degrees of weathering, classified as

W3-W4 grades (IRSM a). There are evident indications of overburden and rock mass failure occurring in this zone. The flat terraced land situated above this slope primarily serves for cultivation and settlement purposes (**Figure 4.15**). Throughout this distressed slope, exposed roots were observed (**Figure 4.16**).

4.1.3 Belly Portion of landslide:

The middle section of the active slide area is described as follows:

It has an elevation between El±920 m to El±925 m and it stretches about 100 m in width and 5 m in length. The main feature of this area is the presence of a thick overburden, with a thickness exceeding 5 m, containing embedded boulders of volcanic rocks.

In terms of material, both rock and overburden have been removed from the upper part of the belly section, whereas fallen rock boulders and debris have accumulated in the belly region. The accumulation of debris, along with some visible boulders, can still be observed in the belly area (**Figure 4.17**). The upper section of the belly can be categorized as a zone of partial depletion, while the terminal part can be considered a zone of partial accumulation.



Figure 4.17 Accumulation of debris, along with some boulders of various sizes along the belly portion of slide

4.1.4 Zone of Accumulation/ Toe Portion of Landslide

The toe is represented by the section between Mangwai Road and the Suketi *Khud*, which lies at elevations of approximately 900 m to 925 m, exhibits moderately steep to gentle slopes. The lower portion of this area displays a heap of slided mass composed of large rock boulders, blocks, and debris.



Figure 4.18 a) Basalt boulders along the Mangwai road at Toe b) Flowing drain into the slided zone c) Accumulated material at the toe of Tarna hill slide

This accumulation forms a gentle cone shape along the Mangwai Road. The zone represents an accumulation area, characterized by a very gentle slope and devoid of any vegetation cover. The predominant materials in this zone consist of cobble to boulder sized rocks, along with sandy and silty materials originating from higher elevations. The rocks of dimensions approx. 3.5 m covered the Mangwai road (**Figure 4.18**). A flowing drain was also observed in the toe portion along the road.

4.2. Slope forming material:

The entire slope is barren and the main slope forming material consists of several boulders to pebble size rock of basaltic composition embedded with sandy and silt material. Isolated rock outcrops were also seen as discernible based on present field work.

4.3. Hydrology:

The distressed area is entirely damp and wet. There are no channel lined drainage in the distressed zone. Several seepages were identified at distressed zone from elevation El±910 m to El±915 m.

4.4 Structural details:

The structural analysis of the *in-situ* rock exposed along the left bank of Suketi *Khud* and along the

Mangwai road corridor the was done. The rocks exposed in the area exhibit three set of joints (**Figure 4.19**). The joints are mainly rough and undulatory.



Figure 4.19 The basaltic rocks exposed in the area exhibiting three set of different sets of joints

The structural details of the three sets of joints including the foliation joints which are tabulated in **Table 4.1** as below: -

Table 4.1: Joint data recorded at the Tarna Hill Landslide site.

Joint	Dip Amount	Dip Direction	Spacing	Persistence	Opening	Surface	Remarks
J ₁	30°-45°	N100°-110°	1cm-2 cm	1.5m-2.5m	0.5 mm -1.0 mm	Undulatory, slightly rough to rough, soft filling of >5mm at places.	Slightly weathered
J ₂	50°-55°	N240°-260°	1cm	1m-1.5m	2.0 mm - 4.0 mm	Slightly rough to smooth at places, clay filling.	Slightly weathered
J ₃	75°-85°	N260°-280°	1cm-2 cm	1.5m-2m	0.2 mm-1.0 mm	Rough, Irregular, calcite filling	Slightly weathered

J₁ represents joints that dip into the valley, while J₂ exhibits oblique dipping and J₃ shows dipping towards the hillside. J₁ is a moderately dipping joint that runs parallel to the slope (valley dipping). It has an undulating and rough surface have calcite /clay filling (**Figure 4.20**).



Figure 4.20 Joints having clay to calcitic filling in joints

J₂, on the other hand, is a moderately dipping joint with a variable dip angle of 50°-55°. Its surface is somewhat rough, and it dips obliquely to the slope without any filling in the aperture openings. Lastly, J₃ represents a nearly vertical joint dipping against the slope (hill ward dipping). When J₁, J₂, and J₃ intersect, they form wedges on the slope profile that have the potential for failure. All observed joints have a low persistence ranging from 1 m to 2 m.

4.5 Geological Observations:

- 1 The general slope angle of the slide is 50°-75° towards N106°.
- 2 The landslide area primarily consists of basalt and quartz arenite from the Mandi Volcanics of the Sundernagar Group. Due to its proximity to the Kullu Thrust and Mandi-Sundernagar Thrust, the rocks in this area are extensively fractured and jointed. The Weathering index at the base of the landslide varies from W3-W4, while near the upper section it is classified as W5 (ISRM, 1981a). The Geological Survey of India (GSI, 2018-2019) has already designated this area as a Moderate landslide susceptibility zone.
- 3 The rock mass is jointed with three sets of joints. The openings along joints are continuous and have clay and calcite filling/coating.
- 4 The slided area of the slide zone is occupied by the overburden material. The estimated thickness of the overburden ranges from 5 m to 7 m, as visually assessed. Within the silty and clayey matrix, there are boulders and clasts of basalts embedded. The soil predominantly consists of sandy to silt and has a greyish to yellowish color. Along the distressed slope, there are several partially detached boulders of basaltic composition, ranging from approximately 50 cm to 2.5 m in diameter, held by the soil. These boulders can be easily detached if the soil becomes loosened by rain. Additionally, most of the terraced areas have been unscientifically modified without proper lined drainage, which could further contribute

to slope instability.

- 5 Failure mechanism observed in landslide is rotational failure
- 6 The slide is enlarging in nature and is confirmed by observing the development of ground cracks as well as cracks on the buildings of adjacent houses. Some cracks also developed on the 15th August after the incidence.
- 7 The landslide occurred as a result of the slope forming material becoming oversaturated due to two consecutive periods of rainfall in July and August 2023. This led to an increase in pore pressure within the soil, causing a reduction in friction along the potential failure surfaces.
- 8 It has been noted that the construction of buildings, civil structures, and other infrastructure development activities carried out in an unplanned or poorly planned manner, as well as the cutting or modification of hill slopes, can increase the likelihood of slope instability incidents or failures. **(Figure 4.21)**
- 9 Some prominent damp zones are also observed in the slide zone. **(Figure 4.22).**
- 10 In terms of Land use and Land cover, the area is occupied by settlements and some small patches of barren/ cultivated area.
- 11 The landslide has affected nearly ± 100 m of the Mangwai road.
- 12 Some blocks are loosely hanging on the belly portion of the slide and are covering a major stretch of the road.



Figure 4.21 Unscientifically constructed houses posing a major threat during natural hazard



Figure 4.22 Damp Zones at the toe portion of the slide

4.6: GEOLOGICAL PROFILE/SECTIONS:

A geological profile was observed and developed with the detailed geological map (Plate-II). A longitudinal profile along the center line of the slide scar has been developed.

4.6.1 Geological-profile of X-Y:

A geological profile labelled X-Y (**Plate-II**) has been created specifically over the landslide area, using a scale of 1:1000, focusing on the central portion of the landslide. This profile showcases the elevation discrepancy between El ± 900 m and El ± 950 m. Within the range of El ± 910 m to El ± 925 m, the profile illustrates a zone of depletion containing loose overburden material along with erratic boulders of basalts in various sizes. Notably, the Mangwai-Rewalsar link road was established at an elevation of El ± 910 m, intersecting the profile. At an elevation of El ± 905 m, a small area of in-situ rock composed of basalts is exposed (**Figure 4.23**).



Figure 4.23 Basalts outcrops exposed at EL ± 905 m

Between the elevations of El ± 910 m to El ± 930 m, the region is predominantly filled with unconsolidated to semi-unconsolidated debris material from Quaternary deposits. The area of increased moisture content, known as the damp zone, is situated at an elevation of El ± 910 m (**Figure 4.24**).



Figure 4.24 Damp Zones located at the Toe of the slide along the Mangwai Road

4.7 Sample collection:

During the geotechnical investigation, intact soil samples were obtained from various points within the landslide area to analyze the strength and shear parameters of both the bedrock and soil, as well as to assess the physical characteristics of the materials.

To understand the contribution of the different materials in the failure mechanism, samples were taken from the slope. The sampling process followed standard protocols. Subsequently, the soil samples were sent to DDMA, Mandi, for onward transmission to NIT Hamirpur HP for analysis. Based on NQT and field assessments, samples were collected along the central axis of the landslide.

4.7.1 Undisturbed Soil samples

During the geological field traverses in and around the slide zone, identified the locations/spots for soil sampling. The undisturbed soil samples were collected from the overburden material found on the either flank of the slide zone (Plate-I).

Following steps were followed while collecting the samples from identified locations

Step-1: Identification of suitable spot / required spot for sample collection.

Step-2: Cleaning the surface properly and avoiding the organic content of the soil.

Step-3: Inserting GI pipe (tube) (Length of pipe 13inch and Diameter 4 inch) within the soil to get undisturbed sample.

Step-4: Sealing both ends of GI pipes properly with molten wax in order to prevent the loss of soil moisture content of the soil.

Step-5: Both the sealed ends of the pipe were covered with tape properly

Step-6: Naming the sample pipe with required code name/ number.

The process of sample collection and steps involved are shown in **Figure 4.25**.

The test carried by National Institute of Technology, Hamirpur, Himachal Pradesh, included the Grain size analysis, Liquid & Plastic limit (Atterberg Limit), Plasticity Index, Shear Parameters Cohesion (C) and angle of internal friction (ϕ), Triaxial of the soil samples, Bearing capacity of the soil, Specific Gravity, Natural Moisture Content (NMC), Density (Dry and Wet), Optimum Moisture Content (OMC), Void Ratio, N (Porosity).

The details of the soil samples are listed in **Table 4.2** below.

Table 4.2: The details of the samples collected from the Tarna Hill landslide site.

Sl.No	Sample type	Sample No	Latitude	Longitude	Elevation
1	Soil	M/T/Toe 1	31°42'19"	76°56'2"	905m
2	Soil	M/T/BE 1	31°42'19"	76°56'1"	925m
3	Soil	M/T/CR 3	31°42'19"	76°55'60"	945m



Figure 4.25 Undisturbed soil sample collection at Tarna Hill Landslide

4.8 Geotechnical properties of soil samples of Tarna Hill Landslide:

Soil development is a gradual process that spans over millions of years to create a thin layer of soil. Due to the intricate mixture of components, the formation of soil is a complex process. The creation of a specific type of soil is influenced by the physico-chemical properties of the parent rock, the intensity and duration of weathering, as well as climatic conditions and other factors.

The slanted slope is primarily covered with loose material that has been moved from its original location and deposited downhill, consisting of rock blocks, sand, and silt of various sizes. Sidle et al. (1985) have identified four natural factors that play a significant role in determining the stability of foot slopes. These factors have been elaborated below:

1. Soil properties especially hydrologic and mineralogical conditions that affect engineering soil behavior and strength properties of the colluvium;
2. Geomorphology including the geologic and tectonic setting, slope gradient, and shape;
3. Hydrology especially soil water recharge and effective evapo-transpiration rates that reflect local climate and vegetation conditions;
4. Vegetative cover including the reinforcing effect of root systems and the loss of such strength when roots deteriorate following timber harvesting or fire; and seismicity, especially the potential for liquefaction of marginally stable soils on steep slopes.

A total of 03 Nos. of soil samples have been collected from the distressed slopes to determine the NMC (Natural moisture content), Void ratio, Porosity, Permeability, c (cohesion), ϕ (friction angle), Attenburg limits, specific gravity, dry unit weight and wet unit weight.

4.8.1 Grain size Analysis:

Grain size analysis is a method used to determine the size of particles in a specific unconsolidated soil unit. The analysis of the 03 soil samples from the study area involved the use of the Sieve analysis technique, which is a fundamental approach to particle sizing. A semi-logarithmic graph was created to show the particle size distribution curves, with percent finer on the x-axis and sieve size (mm) on the y-axis as shown in **Figure 4.25(b)**. The uniformity coefficient (C_u) is calculated as the ratio of particle size D_{60} to D_{10} . A low uniformity coefficient suggests a soil with uniform particle sizes, while a high coefficient indicates a well-graded soil as shown in **Table 4.3 (a)** and **Figure 4.25 (a)**

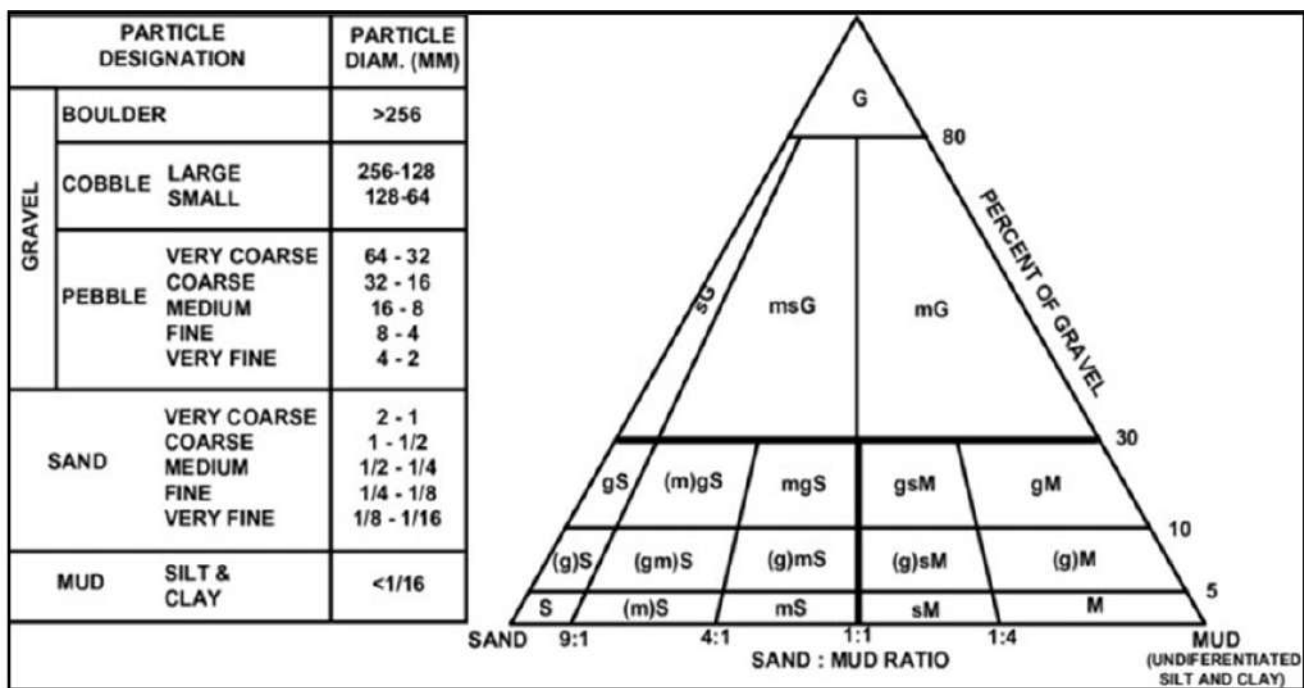

Figure 4.25(a): Sediments textural classification modified after Folk (1968) and Wentworth (1922)

Table 4.3(a): Uniformity coefficient chart (Attewell and Farmer, 1976).

	$D_{60}(\text{size})$ (mm)	$D_{10}(\text{size})$ (mm)	C_u
Uniform gravel	0.80	1.3	1.6
Medium sand	0.15	0.31	2.1
Sandy gravel	0.20	1.5	7.5
Silty sand	0.06	0.56	9.3
Sandy clay	0.001	0.028	28

$$Cu = D_{60} / D_{10}$$

D_{60} = grain diameter corresponds to 60% passing by weight

D_{10} = grain diameter corresponds to 10% passing by weight

A low coefficient of uniformity suggests that the soil consists of particles of the same size, whereas a high coefficient indicates that the soil is well-graded. According to Attewell P.B and Farmer, I.W, the soil sample taken from the toe portion of the slide shows a higher Cu value, indicating that it is well-graded compared to the other samples. Additionally, based on the classification by Folk (1968) and Wentworth (1922), the soil samples from Tarna Hill landslide mainly consist of fine pebbles to very fine sand particles (**Figure 4.25(a)**). The Cu value of these samples ranges from 10.49 to 20.84, with an average of 15.81, suggesting that the soils are predominantly gravel to silty sand and well-graded.

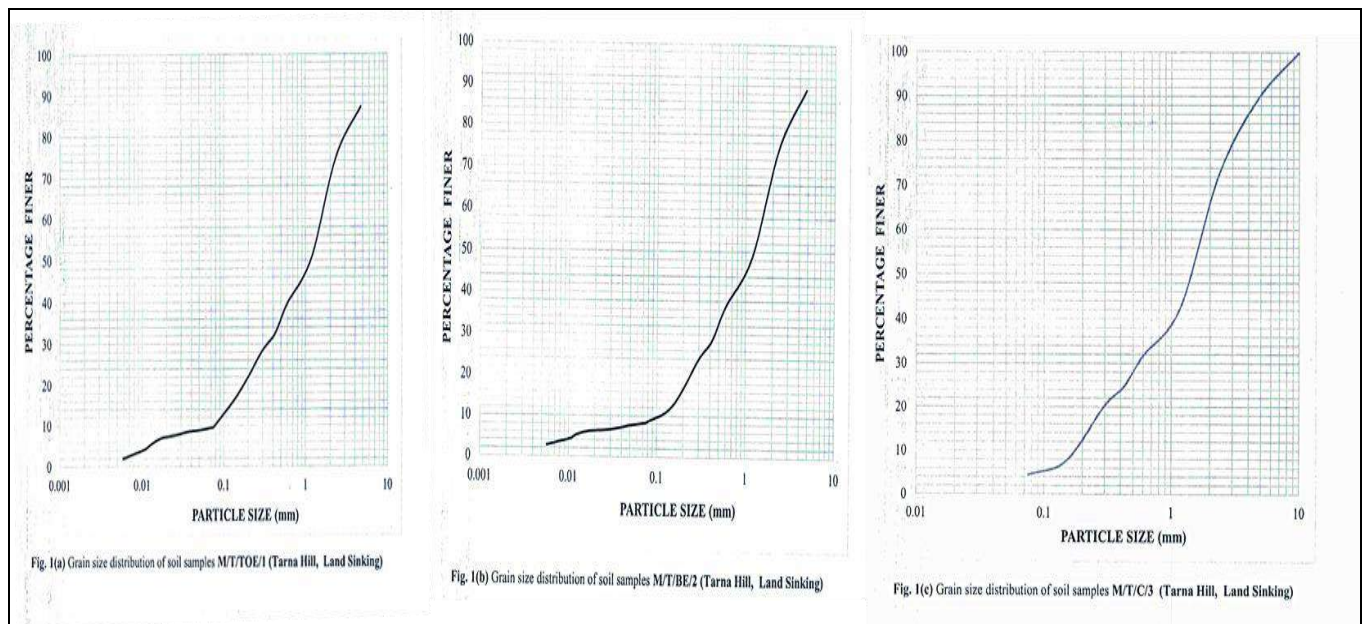

Figure 4.25 (b) Grain size distribution of soil samples

4.8.2 Density:

The density of the soil samples can be determined by considering factors such as the physical characteristics of soil settlement, compatibility, and permeability. There are two types of soil density: dry and wet. The dry density values of the Tarna Hill landslide soil samples range from 15.82 kN/m³ to 16.68 kN/m³, with an average dry density of 16.29 kN/m³.

On the other hand, the wet density values of the soil samples range from 16.90 kN/m³ to 18.23 kN/m³, with an average wet density of 17.66 kN/m³ as represented in **Table 4.3** after Look, 2014.

Table 4.3 Representative range of dry and saturated unit weight (Look, 2014).

Type	Soil description	Unit weight range (kN/m ³)	
		Dry	Saturated
Cohesionless compacted broken rock	Soft sedimentary Chalk, Shale, Siltstone, Coal)	12	18
	Hard sedimentary (Conglomerate, sandstone)	14	19
	Metamorphic	18	20
	Igneous	17	21
Cohesionless Sands and gravels	Very loose	14	17
	Loose	15	18
	Medium dense	17	20
	Very dense	21	22
Cohesionless sands	Loose-uniformly graded	14	17
	Loose-well graded	16	19
	Dense-uniformly graded	18	20
	Dense-well graded	19	21
Cohesive	Soft-organic	8	14
	Soft-non organic	12	16
	Stiff	16	18
	Hard	18	20

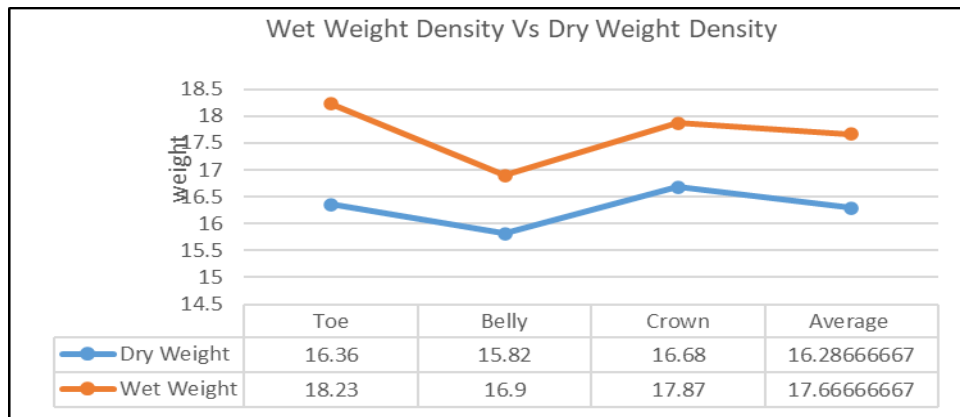

Figure 4.26 Dry and Wet unit weight relationship of soil samples from various locations of Tarna Hill

These sample values indicate that the soil at this site consists of loose cohesionless sand and gravel. The relationship between dry and wet unit weight shows a positive correlation, as depicted in **Figure 4.26**.

4.8.3 Natural Moisture content (NMC):

The natural moisture content, is calculated by dividing the weight of water (WL) by the weight of solids in a specific mass of soil (Wd) and then multiplying by 100%. This ratio is crucial for soil compaction and influences the soil's permeability. As the moisture content rises, the soil's permeability decreases, making it a

key factor in slope failure or landslides. The moisture content of the Tarna Hill slide ranges from 6.86% to 11.42%, with an average of 8.36%. The high moisture content in the Tarna Hill slide indicates poor soil packing.

4.8.4 Specific Gravity:

The soil sample's specific gravity is calculated by comparing the weight of dry soil to the weight of water it displaces. The specific gravity falls between 2.48 and 2.62, with an average of 2.55. The specific gravity of soil samples from the slide area indicates a deficiency of dense materials and the possible presence of organic clay. **Figure 4.27** below illustrates the linear plot of specific gravity for the soil samples from the Tarna Hill landslide.

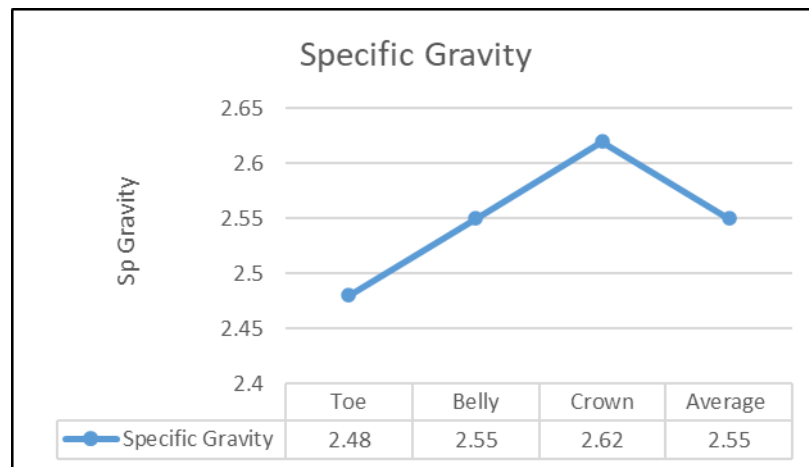

Figure 4.27 The linear plot of specific gravity the soil samples of Tarna Hill landslide.

4.8.5 Permeability:

Permeability refers to the characteristic of a porous substance that enables the flow or infiltration of water through its interconnected spaces. It plays a crucial role in assessing the leakage rate beneath or through a dam, as well as the rate at which a saturated soil can compress under a load. In the case of the Tarna Hill landslide, the permeability of the soil sample ranges from 2.6×10^{-4} to 3.90×10^{-4} , classifying it as medium to fine sand.

4.8.6 Shear strength:

Shear strength is a crucial characteristic of overburden material, referring to its ability to withstand the forces that cause sliding between soil particles. This property is determined by two factors: the angle of internal friction (Φ) and cohesion (c), which are obtained through direct shear testing. The cohesion (c) value typically

ranges from 6.6 to 8.1 kPa, while the angle of internal friction varies between 29.7° and 31°. In the case of sand, it is characterized as having no cohesion and being very loosely packed as represented in **Table 4.4** after Look, 2014. The plot representing relation between Cohesion and friction angle is shown in **Figure 4.28**.

Table 4.4: Typical friction angle of granular soils (Look, 2014)

Type	Description/state	Friction angle (degrees)
Cohesionless Compacted broken rock	Soft sedimentary (Chalk, Shale, Siltstone, Coal)	30-40
	Hard sedimentary (Conglomerate, Sandstone)	35-45
	Metamorphic	35-45
	Igneous	40-50
Cohesionless Gravels	Very loose/loose	30-34
	Medium dense	34-39
	Dense	39-44
	Very dense	44-49
Cohesionless sands	Very loose/loose	27-32
	Medium dense	32-37
	Dense	37-42
	Very dense	42-47
Cohesionless Sands	Loose- uniformly graded	27-30
	Loose –well graded	30-32
	Dense-uniformly graded	37-40
	Dense- well graded	40-42

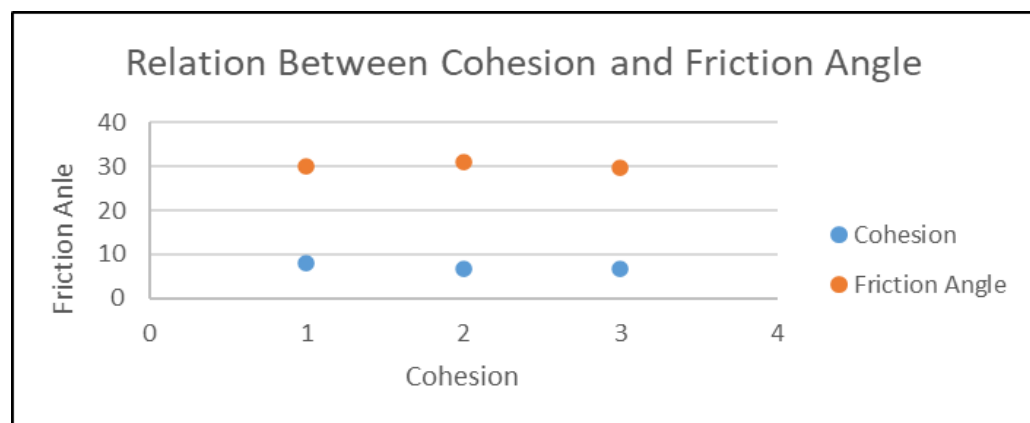

Figure 4.28. Relation between Cohesion and Friction angle

4.8.7 Atterberg Limit:

These limits define the limiting moisture contents at which the soil exists in a plastic, as distinct from a solid,

semi-solid or liquid state, and are dependent on the clay mineral content and related particle size of a clay soil (Attewell and Farmer, 1976).

The Liquid limit of the soil sample varies from 27.4% to 32.5% while the plastic limit varies from 20.4% to 23.8% and the plasticity index (P.I.) varies from 5.8 % to 8.7%. **Figure 4.29** shows the Graph of Atterberg Limit Test of slope failure

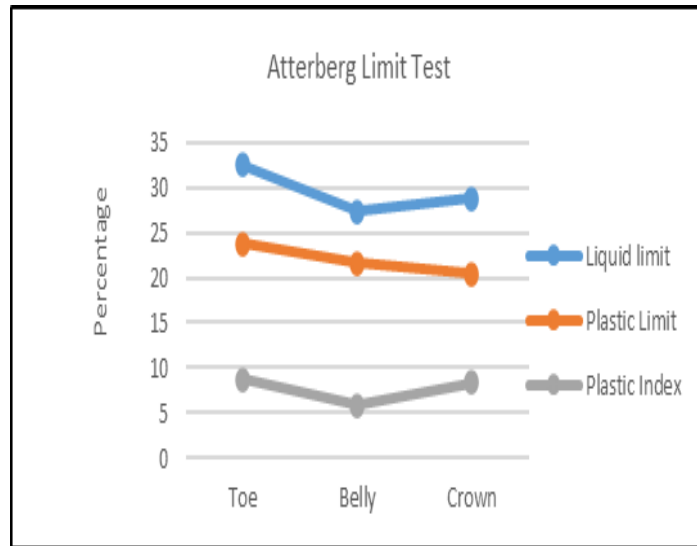

Figure 4.29 Graph of Atterberg Limit Test of slope failure

The plasticity index P.I. is the difference between the liquid and plastic limits and indicates the moisture content range over which the soil remains plastic. This is represented as in equation 3.

$$PI=LL-PL \quad (3)$$

Where PI= Plasticity Index, LL=Liquid Limit and PL=Plastic Limit

Greater the difference, greater is the plasticity of the soil. Soils with a high PI have higher clay content but those with lower PI tend to be predominantly silt. PI is also a measure of cohesiveness with high value of PI indicating high degree of cohesion.

All the soil samples have $LL < 32.5\%$ and $PI < 8.7\%$. The PI vs LL plot chart of slope failure/ soil samples mostly falls under CL-ML. So, they are mostly of inorganic silts, very fine sand, silty or clayey with fine sands of slight to low plasticity and none moderate/medium toughness in nature.

The PI vs LL plot chart of Tarna Hill slide soil samples mostly falls under CL-ML group as indicated by yellow dot in **Figure 4.30** as per the unified classification of soil given by Wagner, 1957 as shown in **Table 4.5a**.

Table 4.5a: Unified classification system for soil (Wagner, 1957).

Field identification procedures (Excluding particles larger than 76 mm and blasting friction on estimate weights)				Group Symbols	Typical names				
Coarse grained soils more than half material is larger than No.200 sieve size(0.08mm)	The No.200 sieve is about the smallest particle visible to naked eye	Gravels more than half of the coarse fraction is larger than No.4 sieve	Clean gravel (little or no finer)	Wide range in grain size and substantial amount of all intermediate particle size	<i>GW</i>	Well graded gravels, gravel-sand mixture, little or no fines.			
				Pre dominantly one size or arange of size with some intermediate size missing	<i>GP</i>	Poorly graded gravels, gravel-sand mixture, little or no fines.			
			Gravel with fines (appreciable amount of)	Non- plastic fines (for identification procedures see <i>ML</i> below.	<i>GM</i>	Silty gravels, poorly graded gravels- sand –silt mixtures			
				Plastic fines (for identification procedures, see <i>CL</i> below.	<i>GC</i>	Clayey gravels, poorly graded gravels- sand – silt mixtures			
			Clean Sands (little or no finer)	Wide range in grain size and substantial amount of all intermediate particle size	<i>SW</i>	Well graded sand ,gravelly sands, little orno fines.			
				Pre dominantly one size or arange of size with some intermediate size missing	<i>SP</i>	Poorly graded sands, gravelly sands, little orno fines			
		Gravel with fines (appreciable amount of fines)	Non- plastic fines (for identification procedures see <i>ML</i> below	<i>SM</i>	Silty- sand, poorly graded sand-silt mixture				
			Plastic fines (for identification procedures, see <i>CL</i> below.	<i>SC</i>	Clayey sand, poorly graded sand- clay mixtures				
		Fine grained soils more than half material is smaller than No.200 sieve size (0.08mm)	The No.200 sieve is about the smallest particle visible to naked eye	Identification procedures on fraction smaller than No.40 sieve size (0.40 mm)					
				Silts and clays liquid limit less than 50	Dry strength (crushing characteristics)	Dilatancy (Reaction to shaking)	Toughness (consistency near plastic limit)		
					None to slight	Quick to slow	None	<i>ML</i>	Inorganic silts and very fine sands, rock-flour, silty or clayey fine sands with slight plasticity
					Medium to high	None to veryslow	Medium	<i>CL</i>	Inorganic clay of low to medium plasticity, gravelly clays, sand clays ,silty clays, lean clays.
Slight to medium	Slow				Slight	<i>OL</i>	Organic silts and organic silts clay of lowplasticity.		
Silts and clays liquid limit greater than 50	Slight to medium				Slow to none	Slight to medium	<i>MH</i>	Inorganic silts, micaceous or diatomaceous, fine sandy or silty soils, elastic silts.	
	High to very high				None	High	<i>CH</i>	Inorganic clays of high plasticity, fat clays.	
	Medium to high			None to veryslow	Slight to medium	<i>OH</i>	Organic clays of medium to high plasticity.		
Highly organic soils	Readily identified by colour, odour, spongy feels and frequently by fibrous texture,			<i>pt</i>	Peat and highly organic soils.				

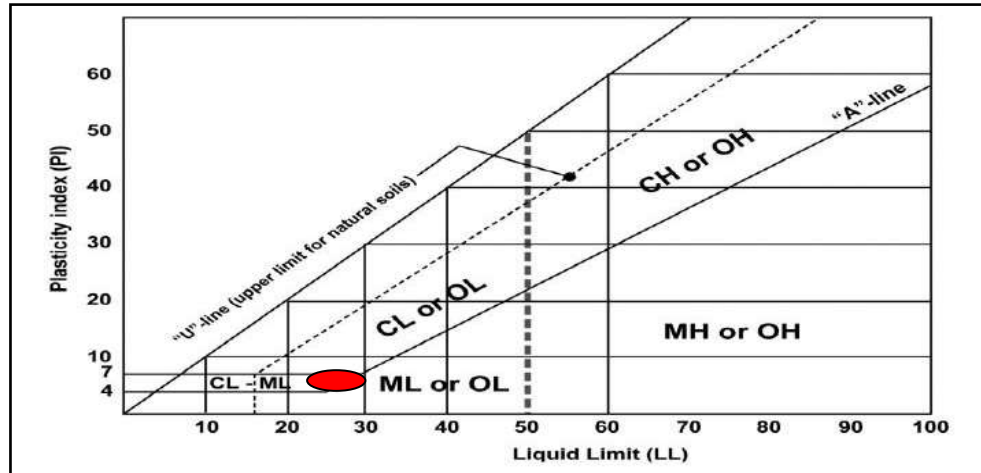

Figure 4.30: Relation between Plasticity index (PI) and Liquid limit (LL) (Attewell and Farmer, 1976)

4.9 Rock Mass Characterization:

The landslide is primarily composed of Quaternary sediments. A linear patch of in-situ rock mass (basalts) was discovered exposed along the right bank of the Suketi *Khud*. A slope stability analysis of the rock mass was conducted along the road corridor, with locations selected based on outcrop occurrences. The mapped rock mass has been characterized through field observations, recording rock surface details, joint/discontinuity details, and utilizing empirically established equations to determine various parameters. Volumetric joint (J_v), Rock Quality Designate (RQD), weathering grade of rock mass, and Uniaxial Compressive Strength (UCS) using a geological hammer were calculated to characterize the rock masses.

4.9.1 Weathering Grade:

Weathering is a complex process that leads to the degradation of rock mass. The extent of degradation is influenced by environmental conditions and the characteristics of the rock mass. As weathering progresses, cracks, fractures, or joints develop on the rock surface, eventually transforming the rock mass into fractured rock or soil-like material, making the slope unstable. This phenomenon has been observed on many critical slopes in the study area, often resulting in successive landslides (Voulgari, 2015). Classifying the rock mass based on its weathering state is essential as weathering can alter the engineering properties of the rock mass. Several researchers have investigated the impact of weathering on the engineering properties of rock mass and have proposed various classifications and guidelines. Understanding the geotechnical behavior of rock mass based on its weathering state is crucial to prevent stability issues. In the study area, the BIS, 1987 classification system is utilized. The rock mass exposed in the area ranges from slightly weathered (Grade II) to moderately weathered (Grade III). The rock mass near the toe is slightly weathered, while those near the

river and crown are moderately weathered.

4.9.2 Determination of Rock Quality Designate (RQD):

RQD has been determined for the three locations of the Tarna Hill landslide, which are listed in **Table-4.5**. According to the rock mass quality classification provided by Deere et.al in 1967, as displayed in **Table 3.1**, the volumetric joint count has been computed using the standard method developed by A. Palmstrom in 1982. The average value of J_v ranges from 07 to 11.

Table:4.5: Volumetric joint counted at site of the Tarna Hill landslide.

Sl. No	Location	Rock types	Average J_v	Converted RQD (%)
a	01	Basalt	11	78.7
b	02	Basalt	7	91.9
c	03	Basalt	7	91.9

4.9.3 Uniaxial Compressive Strength (UCS) of the rock mass:

The Uniaxial compressive strength (UCS) parameters of RMR_{basic} and other geotechnical properties of the rocky slope are determined. The UCS of the rock mass exposed at the slide zone is calculated using the Deere Miller approach. An estimate of the UCS of the rock mass at the site is obtained by striking the rock with a Geological hammer. According to this method, the rocks fall under the R3 category of rock mass, suggesting that the UCS ranges from 25-50 MPa. The UCS value are tabulated in **Table 4.6**.

Table: 4.6-Strength of the rock mass.

S.No.	Location	Rock type	Category
1.	Toe	Basalt	R-3 (Medium-strong)
2.	Toe	Basalt	R-3 (Medium-strong)
3.	River	Basalt	R-3 (Medium-strong)

4.9.4 Rock Mass Rating (RMR):

The RMR for the in-situ rock sites is detailed in **Table 4.7**. The RMR was assessed at a single exposed rock slope at 2-3 points to ensure precision. It has been noted that all these sites are classified as Good due to the exposure of massive rock mass.

The RMR values range from 64 to 69, signifying that the rock at the slide zone is categorized as Class II and

is in Good condition.

4.10 Slope Stability Analysis:

The stability of a slope is influenced by cohesion (c) and the angle of internal friction, which is the ratio of resisting forces (working load) to driving forces (collapse load). A slope is deemed stable when the resisting force exceeds the driving force. The Factor of Safety (FoS) represents the ratio of resisting forces to driving forces and serves as an indicator of slope stability (Bishop, 1955).

Various factors govern the driving and resisting forces. Internal factors include the slope's geometry, characteristics of potential failure planes, surface drainage, and groundwater conditions, while external factors encompass rainfall, seismic activity, and human activities (Raghuvanshi, 2019). The combined influence of these factors determines the stability of the slope. Geology, geomorphology, climate, and human activities are typically the key factors that control slope stability.

The stability assessment of Tarna Hill landslide has been carried out using the two methods, i.e. SMR and Kinematic analysis.

4.10.1 Slope Mass Rating (SMR):

SMR values are calculated by using the technique by Romana (1985) to assess the stability of potentially-failing rock slope and to provide suggestions of effective protection measures as shown in table 29.

The SMR value of the rock mass within the study area varies between 30.00 to 70.00, suggesting the rock slope ranges from Bad (Class IV) to Good condition (Class II). (**Table 4.8**)

As per the SMR assessment, the rock slope exposed along the toe falls under Class-II i.e. Good category. The recommended support measures as per SMR for Tarna Hill landslide zone is given in **Table 4.9**.

Table 4.7: Calculated RMR_{basic} for locations of Tarna Hill site (After Bieniawski; 1989).

Rock slope	UCS (MPa)	RQD (%)	Spacing (mm)	Condition of discontinuities					GW condition	RMR	Class	Description
				Persistence (m)	Separation (mm)	Roughness	Infilling (mm)	Alteration/Weathering				
	25	88.6	100	1	0.1-1	Slightly rough	None	slightly weathered	Dry			
Rating	4	17	8	4	4	3	6	5	15	66	II	Good
	25	91.9	100	1	0.1-1	Slightly rough	None	slightly weathered	Dry			
Rating	4	20	8	4	4	3	6	5	15	69	II	Good
	25	78.7	200	1	0.1-1	Slightly rough	None	Moderately weathered	Dry			
Rating	4	17	8	4	4	3	6	3	15	64	II	Good

Table 4.8: Calculation of Slope Mass Rating (SMR) values

Location	Joint sets/Data (J1,J2,J3)	RMR value	Slope morphology	Mode of failure	Trend of intersection plane	α_j	α_s	α_i	P ($\alpha_j - \alpha_s$)	W($\alpha_i - \alpha_s$)	F1	β_j	β_s	β_i	P/W (β_j or β_i)	F2	P ($\beta_j - \beta_s$)	W ($\beta_i - \beta_s$)	P/W ($\beta_i - \beta_s$)	F3	F4	SMR = $RMR + (F1 * F2 * F3) + F4$	CLASS	Description
1	35°/120°	66	60/N106E	Planar	35°/120°	0	106	120	-14	0	1		60	35	35	0.85	0	-25	-25	-60	15	30	IV	Bad
	55°/230°			Wedge	27/N162	162	106	0	0	-56	1	27	60	0	27	0.4	-33		-33	-60	15	57	III	Normal
	75°/240°			Wedge	28/N158	158	106	0	0	-52	1	28	60	0	28	0.4	-32		-32	-60	15	57	III	Normal
2	38°/100°	69	70/N110E	Planar	38°/100°	0	110	100	10	#RE FI	0.85		70	38	38	0.85	0	-32	-32	-60	15	40.65	III	Normal
3	45°/110°	64	70/N110E	Planar	45°/110°	0	110	110	0	0	1		70	45	45	0.85	0	-25	-25	-60	15	28	IV	Bad
	55°/240°			Wedge	23/N168	168	110	0	0	-58	1	23	70	0	23	0.4	-47		-47	-60	15	55	III	Normal
	80°/260°			Wedge	19/N174	174	110	0	0	-64	1	19	70	0	19	0.15	-51		-51	-60	15	70	II	Good

Table 4.9: Calculated SMR values with their classification and description of suggested support (Romana; et al, 2003)

Class	Rock mass description	Stability	Failure Mode	Probability of Failure	Suggested Support (Romana; et al,2003)	Recommended support methods based on the field condition
IV	Bad	Unstable	Planar	0.6	Re-Excavation wall, Surface Drainage, Deep Drainage, Shotcrete, Dental concrete ribs and/or beams, Toe walls.	Shotcrete
III	Normal	Partially Stable	Planar along some joint and wedges	0.4	Shotcrete, Dental concrete ribs and/or beams, Toe walls Bolts, Anchors Toe Ditch, Toe or Slope fences, Nets	Lining of drainage.
II	Good	Stable	Planar and Wedge	0.2	Bolts, Anchors Toe Ditch, Toe or Slope fences, Nets	Bolts

4.10.2 Kinematic Analysis:

Kinematic analysis has been carried out at 03 RMR/SMR locations with a view to find out different modes of failures. The joint sets recorded at the site have been plotted on stereo net with angle of friction Φ taken based on RMR scheme (Bieniawski, 1979) which provides us a fair idea about the shear strength of rock mass based on the structural data's. Based on the analysis, it has been observed that 03 locations show failure condition- planar and wedge failure. Hence, both planar and wedge mode of failures have been observed in the field, which are corroborated by the kinematic checks.

The rock slopes have majority three sets of joints whose structural data has been collected by extensive field work in the study area. The valuable data of the structural discontinuities of rock mass was then kinematically analyzed to ascertain the possibilities of failure at various locations using Dips software. Most of the rock slopes appear stable on date of field observation but may be prone to slope failure as per kinematic analysis performed subjected to any slope modification or naturally due to gravity. The different types of failure observed are explained in detail below.

The detailed kinematic analysis of rock slopes of study area is shown in **Figure 4.31** (Planar Failure) and **Figure 4.32** (Wedge Failure). Locations of the kinematic checks Tarna Hill landslide is given in **Table 4.10**.

Table 4.10: Locations of the kinematic checks Tarna Hill landslide.

Locations Slope & Dir	Joint sets	Intersection of Joints	Plunge Amount	Plunge Direction	Mode of Failure	
					Planar	Wedge
1. 60°/106°	J ₁ =35°/N120° J ₂ =55°/N230° J ₃ =75°/N240°	(J ₁ *J ₂) (J ₁ *J ₃)	27° 28°	162° 158°	J ₁ (35°/N120°)	J ₁ *J ₂ J ₁ *J ₃
2. 70°/110°	J ₁ =38°/N100° J ₂ =50°/N250° J ₃ =78°/N280°	--	--	--	J ₁ =38°/N100°	--
3. 70°/110°	J ₁ =45°/N105° J ₂ =55°/N240° J ₃ =80°/N260°	(J ₁ *J ₂) (J ₁ *J ₃) (J ₂ *J ₃)	23° 19° 32°	168° 174° 176°	J ₁ =45°/N105°	J ₁ *J ₂ J ₁ *J ₃ J ₂ *J ₃

a. Planar Failure:

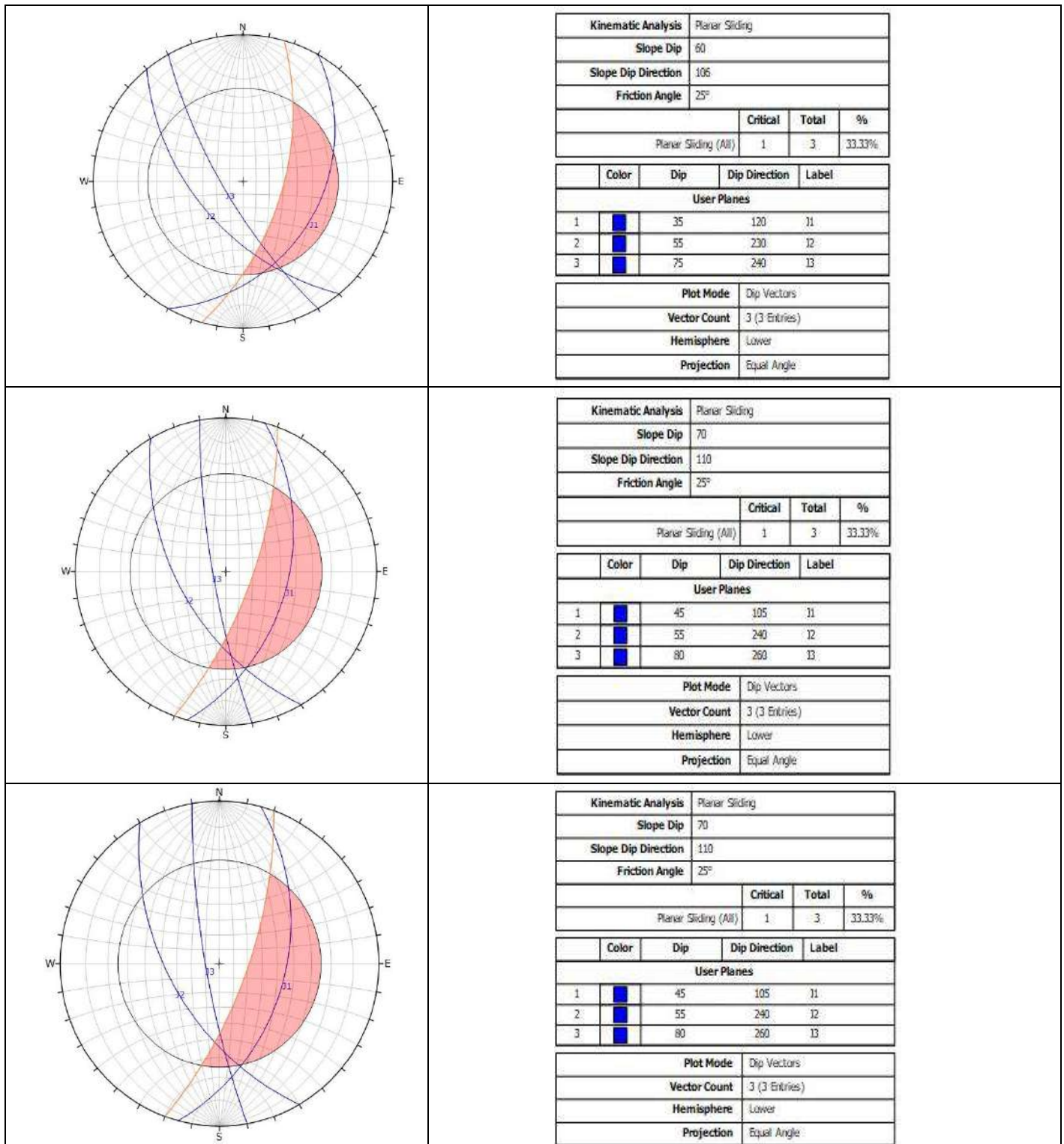

Figure 4.31 Kinematic Checks for Planar failure at locations 1, 2 and 3 at Tarna Hill Landslide.

The failures in the rock slopes are generally controlled by structural discontinuities which act as a plane of weakness to induce movements in the study area. Unfavorable orientation of the moderately dipping J_1 , which is more or less parallel to slope showing planar failure at location 1, 2 and 3. **Figure 4.31** demonstrates the mutual geometric relations between the topography and the most vulnerable discontinuity through stereographic projections at different rock slope at Tarna Hill.

b Wedge Failure:

The intersection of planes of J_1 and J_2 , ($J_1 \wedge J_2$), J_1 and J_3 ($J_1 \wedge J_3$) and J_2 and J_3 ($J_2 \wedge J_3$) forms unstable minor wedges, along day-lighted slope. **Figure 4.30** shows the mutual geometric relations between the topography and the intersection discontinuity through stereographic projections at different rock slope. In location wedge failure is the main failure mode contributed by both J_1 and J_2 and J_1 and J_3 . Similarly, in location 3 wedge failures are anticipated due to intersection of foliation joint J_1 and J_2 , J_1 and J_3 and J_1 and J_2 and J_3 while in location 2 no wedge failure is anticipated.

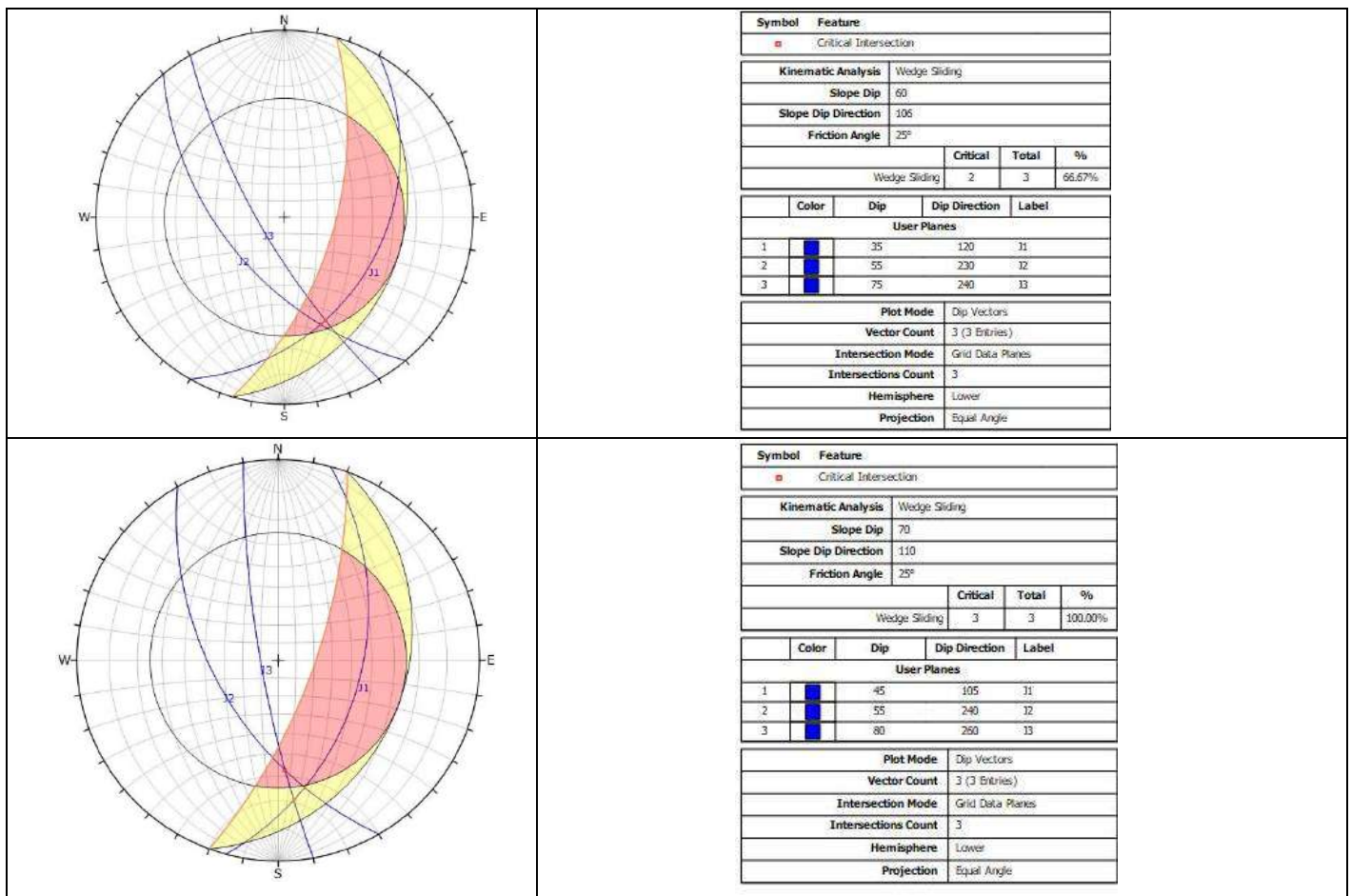

Figure 4.32 Kinematic Checks for Wedge failure at locations 1 and 3 at Tarna Hill Landslide.

4.10.3 Results of Kinematic Checks

From the kinematic analysis, it is found that joints have played minor role in the failure of the rock mass at the site. Unfavorable orientation of the moderately dipping J_1 , which is more or less parallel to slope showing planar failure. The intersection of planes of J_1 and J_2 , J_1 and J_3 and J_2 and J_3 ($J_1 \wedge J_2$, $J_1 \wedge J_3$ & $J_2 \wedge J_3$) forms minor wedges, which are getting day lighted. Hence, both planar and wedge mode of failures have been observed in the field, which are corroborated by the kinematic checks. No joint is liable for toppling mode of failure.

4.10.4 Overall Stability Assessment of the Tarna Hill Landslide Zone

From the results of the SMR and kinematic analysis overall the Tarna Hill landslide Zone is assessed as unstable zone.

4.11 Geotechnical properties of the rock sample:

The geotechnical parameters of the rock are important factor which played essential role in the failure of the slope/formation of slide. However, no rock sample has been collected from the landslide for geotechnical analysis, since the distressed slope is dominated by debris material.

4.12 Discussions:

Tarna Hill landslide is located on the left bank of Suketi *Khud* along Mangwai –Rewalsar road. The elevation of the study area ranges from El \pm 900 m to El \pm 950 m with dimensions of ~100 m (L) x ~120 m (W) x ~50 m (H). The upper limit of the slide is defined by the terraces. The active scarp is very steep exposing loose unconsolidated debris material of undifferentiated quaternary deposit.

Morphometrically, the landslide site is located on a moderate to steep (50° to 60°) slope. After the landslide, the slope at the slide scar becomes modified further and is extremely steep (70°).

The slide is a led to the creation of zone of depletion in upper catchment. The detached debris material form a typical accumulated cone shaped debris deposit at the Mangwai Road on the downslope.

Three sets of joints are recorded along the exposed rock mass. J_1 is a moderately dipping joint which is sub parallel to the slope face (Valley dipping). J_2 with its dip amount varying from 40° - 65° . J_3 is a sub-vertical joint which dips against slope face (hill ward dipping). J_1 have potential for planar failure while J_1 , J_2 & J_3 intersect each other, thus giving rise to form wedges having potential for failure on the slope profile.

A total of 3 Nos. of undisturbed soil samples were collected. The dry density value of Tarna landslide soils samples varies from 15.82 kN/m^3 to 16.68 kN/m^3 Wet density value of the soil samples varies from 16.90 kN/m^3 to 18.23 kN/m^3 The sample value indicates that the soil at this site is of Loose, cohesion less sand

and gravel. The moisture content of slide varies from 6.86 % to 11.42%. The NWC of the slide shows comparatively good packing. The specific gravity ranges from 2.48 and 2.62 and depicts the lack of heavy substances and may contain organic clay. The permeability of the soil sample of Tarna landslide varies from 2.6×10^{-4} to 3.90×10^{-4} i.e. It falls under medium to fine sand category.

Average value of Jv in basalts is 07-11 and RQD varies from 78.7% to 91.9%. RMR varies from 64 to 69 indicating the rock exposed at the slide zone is Class II and falls in Good condition. The SMR value of the rock mass within the study area varies between 30.00 to 70.00, suggesting the rock slope ranges from Bad (Class IV) to Good condition (Class II).

4.13 Slope stability analysis:

Slope stability analysis is performed to assess the safety factor of potential and probable slope failures. In the condition that Factor of Safety (FOS) > 1, the slope will be stable. However, if the FOS < 1, the slope becomes unstable, and slope failures occur. The slope is considered stable when the FOS is greater than one.

When this ratio approaches 1, shear strength and shear stress are approximately equal, and the slope is on the verge of failure or critical condition. The Factor of safety (FOS) was determined using The circular failure charts also. The slope stability analysis was conducted for the middle sections of the zone and the FOS value closest to the field observations was considered as the final value.

The profile section lies in the central portion of the subsidence zone. The data incorporated to carry out the stability analysis is specified in **Table 4.10(a)**.

Table 4.10(a): Soil properties of Tarna Hill

Sl. no.	Soil properties	
1	Slope Height	40m
2	Angle	60°
3	Cohesion	6.66 KPa
4	internal friction angle	31°
5	Dry Density	15.82 KN/m ³
6	wet density	16.9 KN/m ³

With the Circular Failure Chart (CFC), FOS is computed across several groundwater flow schemes to adjust the pore water pressure in the subsurface and stresses due to water present in tension fractures i.e.

Fully drained at 0% Groundwater condition to completely saturated slope due to heavy water recharge. The FOS at various ground water conditions is tabulated in **Table 4.10 (b)**

Table 4.10(b): Soil properties of Tarna Hill

SLOPE Factor of Safety Calculated by Circular Failure Chart by Hoek and Bray Chart		
Ground water Condition	Calculated FOS Dry	Calculated FOS Wet
100%	0.566	0.525
75%	1.029	1.036
50%	1.137	1.118
25%	1.157	1.127
0%	1.843	0.186

These results indicate that the slope is unstable and has reached the failure condition as FOS for both wet and dry lies below 1 when completely saturated. The chart for FOS calculation at fully saturated is given in **Figure 4.32 (b)**.

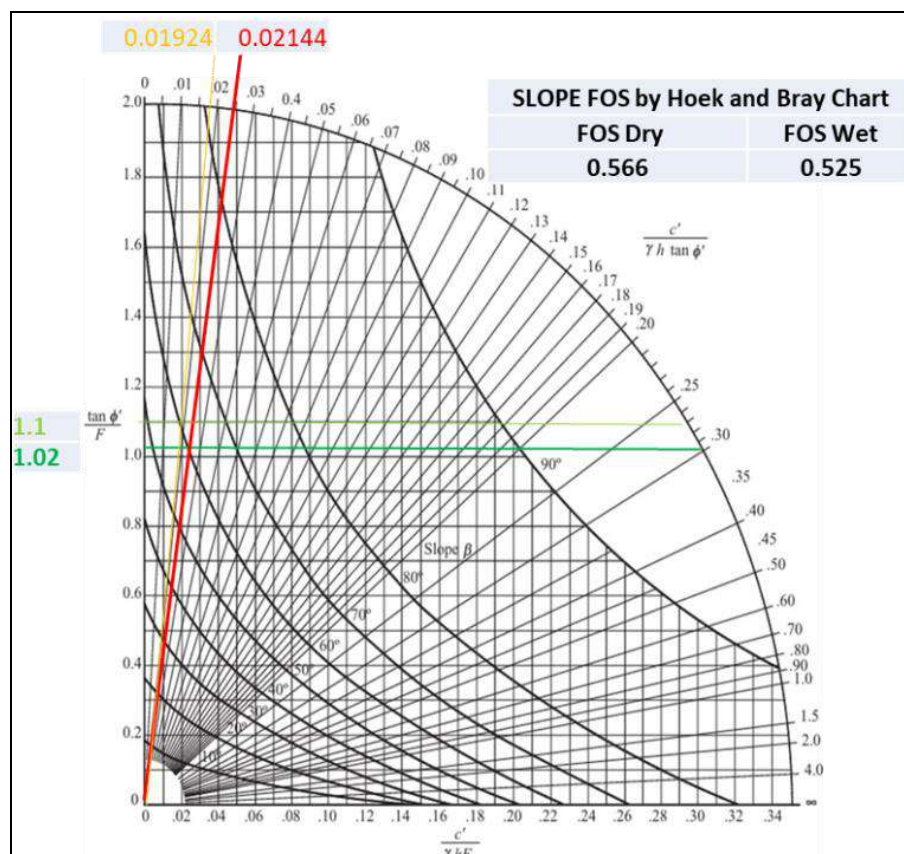

Figure 4.32(b) Calculation of Factor of Safety at Tarna Hill Landslide by Circular Failure Chart

4.14 Contributing and Causative Factors

In order to identify the failure mechanism, the contributing and causative factors should be clearly identified for any particular site. An attempt has been made to identify the geo-genic and also the anthropogenic contributing and causative factors for this slide.

4.15 Geo-genic Contributing Factors

Following geo-genic factors have been identified which have contributed to inducing the instability in the Tarna landslide zone

1. The slope having an inclination of approx. 50° - 70° further facilitated the rapid movement of debris material and erosion of surrounding hill slope.
2. Flood like situation in Suketi *Khud* in first week of July, 2023 eroded the toe area of the unstable slope damaging the pillars on the river bed level and the retaining structures erected to protect the unstable slope mass of Tarna Hills. These were followed by continuous rains during 12th-14th August, 2023 which further saturated the loose slope forming material.
3. An earthquake was also recorded on 5th of August, 2023 having a magnitude of 5.8 with its epicenter is in Hindu Kush Region and was felt widely in the Himachal Pradesh and NCR, Delhi regions of India (Reference Report No.: NCS-NSN-EPG-05).
4. The tremors might have weakened the already saturated loose unconsolidated soil mass.
5. Climatic anomalies have been observed and thus there is significant reduction in the number of rainy days while exhibiting significant increase in the intensity of rainfall.
6. Over Saturation of water within the fragile and loose slope forming material during heavy precipitation reducing shear strength properties of the material.
7. The open joints provided an avenue for the entrance of surficial water along with them and thus contributed towards the development of active stress in the form of piezo metric head/stress.
8. As per RMR, the rock mass falls in Class II (Good category), whereas overall SMR indicates the rock mass as a Fair category. The results of the kinematic checks indicate planar failure along with the foliation joint J_1 and wedge failure due to the intersection of $J_1 \wedge J_2$, $J_1 \wedge J_3$ and $J_2 \wedge J_3$ joints.

4.16 Anthropogenic Causative Factors

It was also observed that due to various anthropogenic activities like construction of buildings, civil structures and other infra-structure development activities in unplanned/less-planned manner, cutting/modification of hill slopes lead to possibilities of slope instability incidences/failures.

4.17 Type of Slide

From the field observations, it is clear that the slide is a typical example of a rotational failure.

4.18 Recommendation/remedial measures

The Tarna Hill landslide is located on the left bank of Suketi *Khud*. After the incidence, the slope has been deeply incised and eroded extensively leading to develop steep slope. The active scarp is steep exposing loose unconsolidated debris material of undifferentiated quaternary deposit and few erratic exposures of Mandi Volcanics. Several instability signatures were observed during field work.

For containing the Tarna Hill Landslide, the following remedial measures are suggested based on the detailed field observation and analytical results. As a basic principle of slope protection measures, attempts are made to suggest measures i) for strengthening the shearing strength and reduction of the shear stress of slope forming material, ii) to manage surface drainage for controlling pore water pressures and to restrict/avoid recharging of fragile groundmass and iii) to restore and strengthen the bench for Mangwai road corridor. Accordingly, the following slope protection measures are suggested at different stages and levels of this landslide.

1. In the crown portion at elevation El±950 m, it is recommended to construct a lined drainage parallel to contour and joined/discharge the domestic water/ other drains coming from up slope to prevent saturation of water in debris material.
2. Sealing of ground cracks wherever possible by impervious material (impervious clay, tar etc.) to restrict water infiltration. Area above the crown of landslide needs to be monitored for development of any new ground cracks. The cracks must be sealed either by filling them with clay or other impervious fill like Bentonite to reduce further permeability to ensure surface water does not pond in the area.
3. Several loose boulders present on the slope area between crown and Mangwai road corridor can be removed manually and modify the slope into benches at different elevations maintaining equal horizontal and vertical slope using adequate retaining wall structure with a provision of weep holes.
4. The unstable slope mass may be filled with reinforced soil fill to increase the shear strength of the soil. The type and quality of reinforced elements may be designed with the concerned design engineers.
5. Bio restoration of the slide area in consultation with Botanist coupled with wire meshes and debris fall barriers. The slope shall be stabilized with the help of active ground anchors of design capacity and dimensions
6. Soil reinforcement in the form of soil nailing can be used to improve the bearing capacity of the soil mass.

7. Reconstruction of breast and retaining structures along the road with adequate filter and drainage, in particular, when constructed in debris filled mass.
8. The retrofitting of the buildings with weakened foundations can be considered in due consultation with the design engineers
9. Ensuring construction of the civil structures by strictly following relevant BIS codes/National Building Code of India.
10. The development of infrastructure, any slope modification etc. must take into consideration the geo-scientific evaluation of inherent risk and hazards in that locality/ spot.

4.19 INSTRUMENTATION

Landslide instrumentation makes use of crack and joint meters for accurate monitoring of displacement/opening of cracks in the rock mass, buildings, and structures.

4.19.1 Subsurface Instruments: -

- 1) Subsurface lateral movements monitoring can be done with in-place inclinometers.
- 2) Pore water pressure variations and monitoring of the landslide area is carried on by piezometers.
- 3) Borehole extensometers are used for the monitoring of sub-surface settlements at specified points.

4.19.2 Surface Instruments: -

- 1) Tilt meters are used in one or more locations of the retaining wall/building falling within the zone of influence. It measures any change in slope inclination near cracks and areas of maximum anticipated rotational movement.
- 3) To delineate the creeping zone, which can trigger the landslide by external forces, a GPS registered INSAR monitoring can be very effective to be placed near the landslide zone.
- 4) Rain gauge for monitoring rainfall

CHAPTER-5

KANGNIDHAR LANDSLIDE

5.0 Introduction:

A detailed geological survey was conducted on the Kanganidhar landslide, covering an area of 0.098 square kilometers on a scale of 1:1000. The landslide is situated on the right bank of the Suketi *Khud* at coordinates 31°42'18" N and 76°56'6" E, specifically on Survey of India. Toposheet No. No.53A/14. It is located approximately 1.8 kilometers southwest of Mandi town in the Mandi District of Himachal Pradesh. The occurrence of this landslide can be attributed to continuous rainfall on the 12th and 13th of August, 2023, with the actual event taking place on the 14th of August. As a result, the National Highway was blocked, causing disruption to vehicular traffic. Additionally, some buildings experienced cracks due to the slide.

Furthermore, the uprooting of electric poles occurred as a consequence of the landslide. To prevent further water saturation and potential worsening of the slide, the water from domestic drains has been redirected to the nearest nala.

Based on its morphometry, the Kanganidhar landslide is classified as a debris slide, which is a type of rotational failure. This particular type of landslide is typically triggered by heavy rainfall, leading to slope saturation and subsequent weakening of the slope debris, resulting in rotational failure. The morphometry of the slide is depicted in **Figure 5.1**.

The current state of the slide is active, with its lower part extending to the middle section of the hill near the National Highway. The area is characterized by generally steep slopes, which could contribute to the instability of the hillside.

The landslide area primarily consists of basalt and quartz arenite from the Mandi Volcanics of the Sundernagar Group. The weathering index at the lower part of the slide ranges from W4 to W5, indicating moderate to severe weathering according to the ISRM (1981a). The Geological Survey of India (GSI, 2018-2019) has already classified the area as a Moderate landslide susceptibility zone, which is consistent with the observed geological conditions.

The elevation of the study area ranges from El ± 920 m to El ± 880 m. The dimensions of the slide were 30 m in height and 80 m in width, affecting nearly 80 m of the National Highway road.

The active scarp is extremely steep, exposing loose unconsolidated debris material of undifferentiated quaternary deposit, along with some boulders of basalt and quartz arenite. The active scarp is characterized

by its steep slope, revealing loose debris material (**Figure 5.2**).



Figure 5.1 Morphometry of the Kanganidhar Landslide.



Figure 5.2 The active scarp characterized by steep slope exposing loose debris material

The slide area was extensively mapped using a total station by surveyor deployed by the district administration. The surveyor was in charge of developing the survey plan for the slide. **Plate-III** displays a comprehensive geological map that includes detailed information on the landslide's morphology, different lithounits, structural data, and various types of overburden materials.

The landslide is located on a steep slope (65°- 75°) on the right bank of the Suketi *Khud*, which flows continuously towards the east. After the landslide, the slope at the scar site underwent additional changes and became steeper, surpassing 80°. This event led to the creation of both a depletion zone and an accumulation zone. The geological map illustrates the active scar of the landslide, which has an irregular shape. The debris material detached at the road forms a typical cone-shaped accumulation. The perimeter along the scar profile measures around 100 m, with a vertical height of 40 m.

5.1.1 Crown portion:

The slide's crown area, is the uppermost part of the slope, located above the head region, has elevations varying from El ± 920 m to EL ± 910 m. It extends around 60 m in distance and encompasses roughly 0.0016 sq.km in area. The incline on this side is marked by steep angles, ranging from approximately 60° to 75° (**Figure 5.3**)

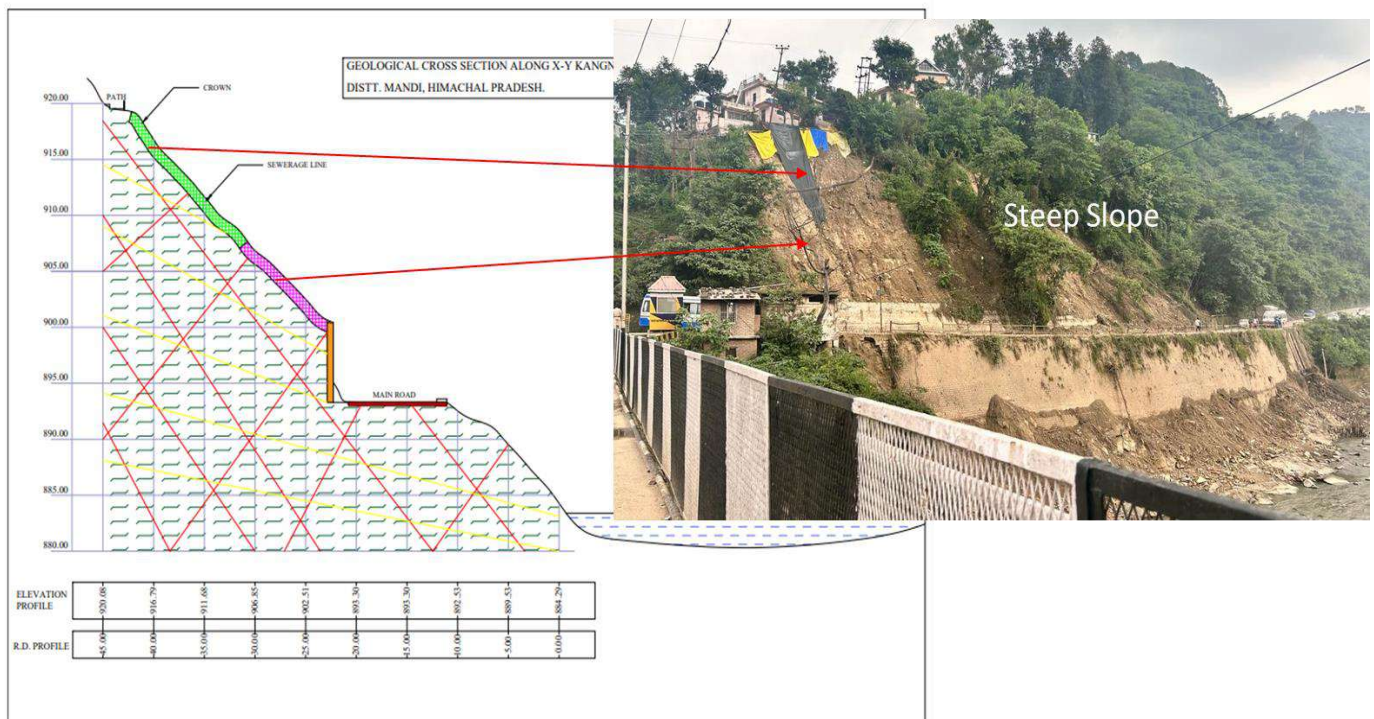

Figure 5.3 Crown characterized by steep slope, ranging from ~65° to ~75°.

The overlying material consists mostly of fines with a certain proportion of coarse cobble particles (**Figure 5.4**).



Figure 5.4 Overlying material consisting of fines and course cobble sized particles

5.1.2 Head:

The head portion of the slide is positioned right under the Crown. Extending 40 m long and 5 m high, the scar covers an area of 0.0012 sq. km. The upper part is characterized by a 3-meter thick layer of soil between elevations ± 905 m and ± 910 m (Plate-III). The slopes on this side maintain a steep angle of around 80° , facing the northwest direction. This side is filled with a substantial amount of debris, mainly fine particles with some larger cobble-sized fractions.

5.1.3 Belly Portion of landslide:

The central part of the active slide area is referred to as the belly. It is situated at an elevation ranging from El ± 900 m to El ± 905 m and spans approximately 40 m in width and 05 m in height. The prominent characteristic of this region is the existence of a substantial overburden, exceeding 5 m in thickness, which contains cobble-sized boulders composed of volcanic rocks.

The upper portion of the belly can be classified as a partial depletion zone, whereas the terminal section can be regarded as a partial accumulation zone.

5.1.4 Zone of Accumulation/ Toe Portion of Landslide

The toe region is defined as the stretch between National Highway and the Suketi *Khud*, situated at elevations ranging from approximately EL \pm 885m to EL \pm 900m. It features slopes that vary from moderately steep to gentle, with inclinations of 60-65°. The lower part of this area showcases a collection of displaced masses, comprising of sizable rock boulders, blocks, and debris. The primary constituents found in this zone are cobble-sized rocks, accompanied by sandy and silty materials that originate from higher altitudes.

5.2. Slope forming material:

The entire area is devoid of much vegetation. The primary material making up the slope ranges from large boulders to small pebbles of basaltic composition mixed with sandy and silty material. Some isolated rock outcrops were also noted.

5.3. Hydrology:

Overall, the distressed area is damp and wet. There was no channelized lined drainage in the distressed zone.

5.4 Structural details:

The structural analysis was conducted by analyzing the in-situ rock found along the right bank of Suketi *Khud* and the in-situ rock exposed along the National Highway. Three distinct sets of joints in the exposed rocks (**Figure 5.5**). These joints are predominantly characterized by their rough and undulating nature.

Table 5.1 presents the three sets of joints observed in the rock mass, including the foliation joints. These joints are categorized as follows:

- J₁ represents joints that dip into the valley.
- J₂ exhibits oblique dipping.
- J₃ shows dipping towards the hillside.

J₁ is a moderately dipping joint that runs parallel to the slope (valley dipping). It is characterized by an undulating and rough surface with calcite/clay filling, as shown in **Figure 5.6**.



Figure 5.5 Basalt outcrop exhibiting three set of joints



Figure 5.6 Joints having clay to calcite filling in joints

J₂, conversely, is a joint that dips moderately with a variable dip angle of 50°-55°. It has a somewhat rough surface and dips obliquely to the slope without any filling in the aperture openings. In contrast, J₃ is a nearly vertical joint that dips against the slope (hill ward dipping). The intersection of J₁, J₂, and J₃ creates wedges on the slope profile that could lead to failure. The observed joints all have low persistence, ranging from 1m to 2m.

Table 5.1: Joint data recorded at Landslide site.

Joint	Dip Amount	Dip Direction	Spacing	Persistence	Opening	Surface	Remarks
J ₁	30°-45°	N100°-110°	01cm-2 cm	1.5 m-2.5m	0.5 mm - .0 mm	Undulatory, slightly rough to rough, soft filling of >5mm at places.	Slightly weathered
J ₂	50°-55°	N240°-260°	01cm	1.0 m-1.5m	2.0 mm-4.0mm,	Slightly rough to smooth at places, no filling.	Slightly weathered
J ₃	75°-85°	N260°-280°	01cm-2 cm	1.5m-2m	0.2m m- 1mm	Rough, Irregular, no filling	Slightly weathered

5.5 Geological Observations:

1. The general slope angle of the slide is 65° - 75° towards 280° .
2. The landslide region primarily comprises basalt and quartz arenite from the Sundernagar Group's Mandi Volcanics. The Weathering index at the base of the landslide ranges from W4-W5, while it is classified as W5 near the upper section (ISRM, 1981a). The Geological Survey of India (GSI, 2018-2019) has already designated this area as a Moderate landslide susceptibility zone.
3. The overburden material occupies the slided area of the slide zone. The estimated thickness of the overburden ranges from 3-5 m, as visually assessed. The landslide is a result of rotational failure.
4. The slide is progressively expanding, evident from the development of ground cracks and cracks on adjacent buildings.
5. The landslide occurred due to oversaturation of the slope forming material caused by two consecutive periods of rainfall in July and August 2023. This resulted in increased pore pressure within the soil, reducing friction along potential failure surfaces.
6. The rock mass exhibits three sets of jointed formations. The joints have continuous openings and are filled/coated with clay and calcite.
7. The area is predominantly occupied by settlements, with some small patches of barren or cultivated land in terms of land use and land cover.
8. The road passing through the slide zone has a length of approximately 80 m.

5.6 Geological profile/sections:

A geological profile was observed and developed with the detailed geological map (Plate-IV). A longitudinal profile along the center line of the slide scar has been developed.

5.6.1 Geological-profile of X-Y:

A geological profile labelled X-Y (Plate-IV) has been specifically created for the landslide area, using a scale of 1:1000, with a focus on the central part of the landslide. This profile highlights the difference in elevation between El \pm 880 m and El \pm 920 m. Within the range of El \pm 905 m to El \pm 920 m, the profile demonstrates a zone of depletion that contains loose overburden material and erratic boulders of basalts in different sizes. It is worth mentioning that the NH was established at an elevation of El \pm 895 m, intersecting the profile.

Between the elevations of El \pm 885 m to El \pm 900 m, the area is mainly filled with unconsolidated to semi-unconsolidated debris material comprising Quaternary deposits.

5.7 Sample collection:

Throughout the geotechnical investigation, undisturbed soil samples were collected from different locations within the landslide zone to examine the strength and shear properties of the bedrock and soil, and to evaluate the physical attributes of the materials. In order to comprehend the role of various materials in the failure process, samples were extracted from the slope and forwarded to DDMA, Mandi, for subsequent dispatch to NIT Hamirpur HP. Following NQT and on-site evaluations, samples were gathered along the central axis of the landslide.

5.7.1 Undisturbed Soil samples

Soil sampling locations were identified during the geological field traverses conducted within and around the slide zone. The purpose was to collect undisturbed soil samples from the overburden material.

The sample collection is shown in **Figure 5.7**.



Figure 5.7 Undisturbed soil sample collection at Kanganidhar Hill Landslide

The tests carried out included the Grain size analysis, Liquid & Plastic limit (Atterberg Limit), Plasticity Index, Shear Parameters Cohesion (C) and angle of internal friction (ϕ), Triaxial of the soil samples, Bearing capacity of the soil, Specific Gravity, Natural Moisture Content (NMC), Density (Dry and Wet), Optimum Moisture Content (OMC), Void Ratio, N (Porosity). The details of the soil samples are listed in **Table 5.2** below.

Table 5.2: The details of the samples collected from Kanganidhar landslide site.

Sl. No	Sample type	Sample No	Latitude	Longitude	Elevation
1	Soil	M/KA/C/1	31°42'18"	76°56'6"	915m
2	Soil	M/KA/Toe/1	31°42'19"	76°56'7"	905m

5.8 Geotechnical properties of soil samples:

1. The engineering soil behavior and strength properties of the colluvium are influenced by various soil properties, particularly the hydrologic and mineralogical conditions. These factors play a crucial role in determining how the soil will behave under different conditions, impacting its overall stability and strength.
2. The geomorphology of the area, including the geologic and tectonic setting, slope gradient, and shape, also plays a significant role in understanding the behavior of the soil. These factors provide valuable insights into the overall landscape and how it may affect the stability of the soil in the area.
3. Hydrology, particularly soil water recharge and evapotranspiration rates, are influenced by local climate and vegetation conditions.
4. Vegetative cover, such as root systems, can reinforce soil strength, but this strength may be lost after timber harvesting or fire. Seismicity, especially the potential for liquefaction on steep slopes, is also a significant factor to consider.

A total of 02 Nos. of soil samples have been collected from distressed slopes to analyze various properties such as NMC, void ratio, porosity, permeability, cohesion, friction angle, Atterberg limits, specific gravity, dry unit weight, and wet unit weight.

5.8.1 Grain size Analysis:

An indication of a low coefficient of uniformity implies that the soil is composed of particles that are uniform in size, while a high coefficient suggests that the soil is well-graded. Attewell P.B and Farmer, I.W found that the soil sample extracted from the base of the slope exhibits a higher C_u value, signifying that it is well-graded in comparison to the other samples. Moreover, following the classification by Folk (1968) and Wentworth (1922), the soil specimens from the Kanganidhar landslide primarily consist of fine pebbles to very fine sand particles. The C_u values of these samples range from 9.16 to 13.83, with an average of 11.49, indicating that the soils are predominantly gravel to silty sand and well-graded. The grain size distribution of the soil samples is enumerated in **Figure 5.8 (a)**

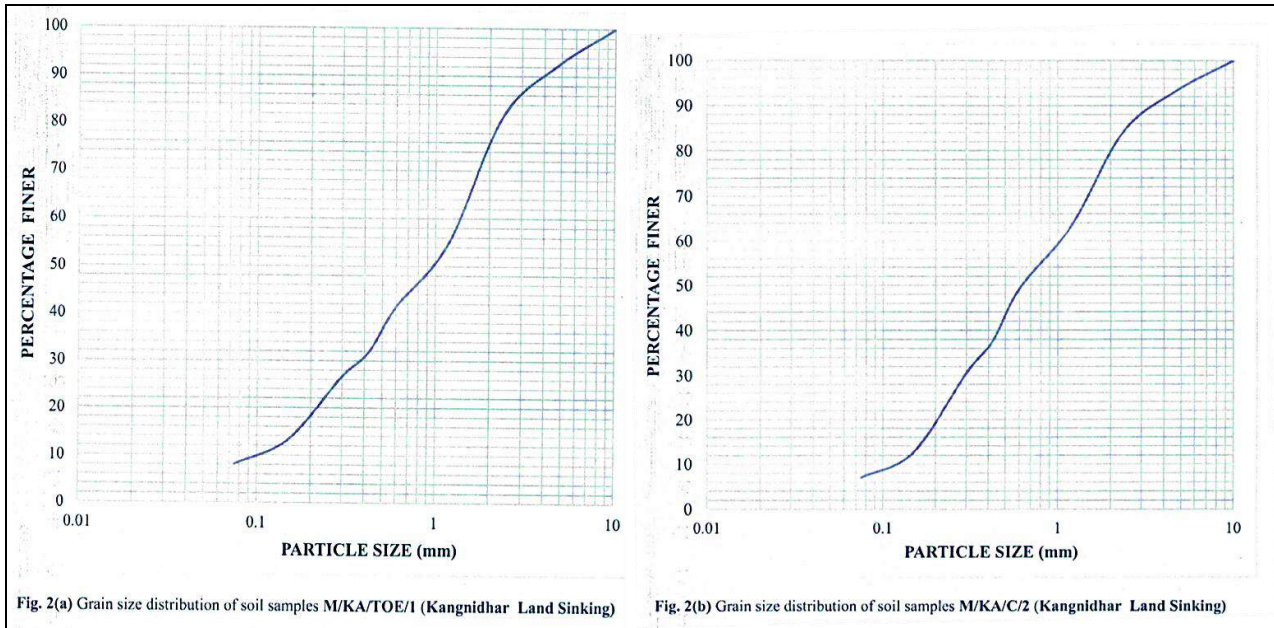

Figure 5.8 (a): Grain size distribution of soil samples

5.8.2 Density:

The soil samples collected from the site exhibit dry density values ranging between 15.00 kN/m³ and 16.32 kN/m³, with an average dry density of 15.66 kN/m³. Conversely, the wet density values of the soil samples range from 16.12 kN/m³ to 17.60 kN/m³, with an average wet density of 16.86 kN/m³.

These findings suggest that the soil composition at the location primarily consists of loose cohesionless sand and gravel, as indicated in **Table 4.3**. Additionally, there is a positive correlation between the dry and wet unit weight, as illustrated in **Figure 5.8**.

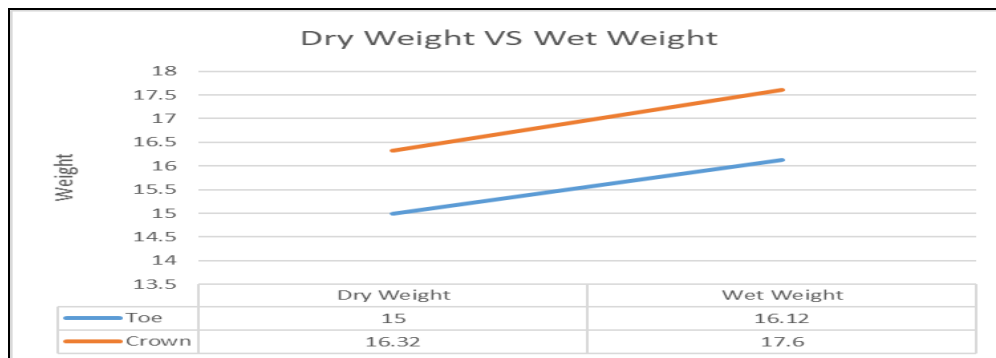

Figure 5.8 Dry and Wet unit weight relationship of soil samples

5.8.3 Natural Moisture content (NMC):

Slope failure or landslides can be attributed to the decrease in permeability of soil as its moisture content increases. The moisture content of the slide varies between 7.44% and 7.79%, with an average of 7.62%. The presence of high moisture content in the soil suggests inadequate soil packing, which further contributes to the risk of slope failure or landslides.

5.8.4 Specific Gravity:

The range of specific gravity values for the soil samples falls between 2.49 and 2.60, with an average value of 2.54. The analysis of the specific gravity of soil samples collected from the slide area suggests a lack of compact materials and suggests the potential existence of organic clay. The linear plot in **Figure 5.9** provides a visual representation of the specific gravity values for the soil samples

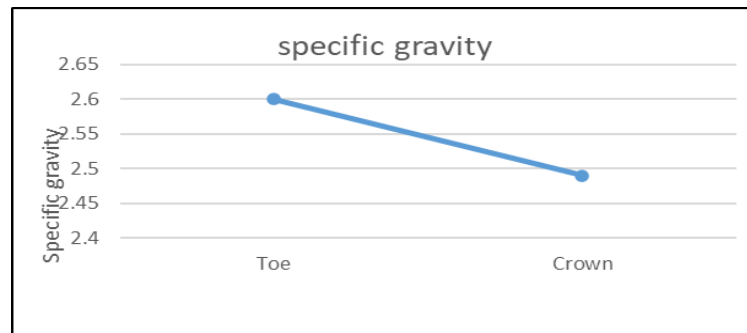

Figure 5.9 The linear plot of specific gravity the soil samples.

5.8.5 Permeability:

The Kanganidhar landslide is characterized by soil samples with a permeability ranging from 2.5×10^{-4} to 2.60×10^{-4} , indicating that it falls within the classification of medium to fine sand in terms of permeability.

5.8.6 Shear strength:

The range of cohesion (c) values usually falls between 4.9 and 6.2 kPa, whereas the angle of internal friction can vary from 30.0° to 31.0° . Sand, on the other hand, is described as lacking cohesion and being loosely packed according to **table 4.4**. **Figure 5.10** gives the relationship between the Cohesion and Friction angle.

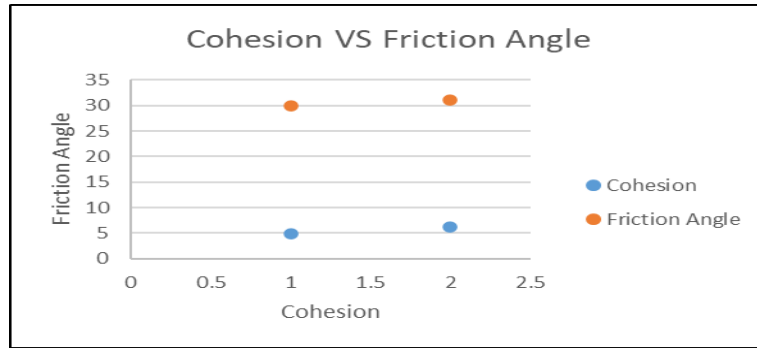

Figure 5.10. Relation between Cohesion and Friction angle

5.8.7 Atterberg limit:

The soil sample exhibits a range of liquid limits from 27.9% to 31.1%, plastic limits from 20.8% to 22.82%, and plasticity index (P.I.) values from 7.1% to 8.9%.

The Graph of Atterberg Limit Test in **Figure 5.11** illustrates the variations in liquid limit, plastic limit, and plasticity index of the soil sample.



Figure 5.11 Graph of Atterberg Limit Test of slope failure

The PI vs LL plot chart indicates that the majority of the slide soil samples belong to the CL-ML group based on their Atterberg limits. As per **Table 4.5(a)**

5.9 Rock Mass Characterization:

The road corridor underwent a slope stability analysis of the rock mass, where specific locations were chosen based on the presence of outcrops. The rock mass was thoroughly examined through field observations, which involved documenting the surface features of the rocks, the details of joints and discontinuities, and applying established equations to calculate different parameters. These parameters included the volumetric joint (J_v), Rock Quality Designate (RQD), the weathering grade of the rock mass, and the Uniaxial Compressive Strength (UCS) determined using a geological hammer. These calculations

were crucial in characterizing the rock masses.

5.9.1 Weathering Grade:

The rock mass exposed in the area falls in slightly weathered category (Grade II).

5.9.2 Determination of Rock Quality Designate (RQD):

The RQD has been assessed for a specific site. Based on the rock mass quality classification outlined by Deere et.al in 1967, as presented in Table 3.1 and 3.2, the volumetric joint count has been calculated using the standardized approach developed by A. Palmstrom in 1982. The resulting average value of J_v is 07 and RQD is 91.9% as shown in **Table 5.3**.

Table: 5.3: Volumetric joint counted at site.

Sl.No	Location	Rock types	Average J_v	Converted RQD (%)
1	01	Basalt	07	91.9
2	02	Basalt	07	91.9

5.9.3 Uniaxial Compressive Strength (UCS) of the rock mass:

The determination of the Uniaxial compressive strength (UCS) parameters for RMR_{basic} and other geotechnical properties of the rocky slope has been conducted. The Deere Miller approach has been utilized to calculate the UCS of the rock mass present in the slide zone. By striking the rock with a Geological hammer, an estimation of the UCS of the rock mass at the site has been obtained. This method categorizes the rock as falling under the R3 category of rock mass, indicating that the UCS ranges from 25-50 MPa. As shown in **Table 5.4**.

Table: 5.4-Strength of the rock mass.

Sl. No.	Location	Rock type	Category
1	Toe	Basalt	R-3 (Medium-strong)
2	Toe (River)	Basalt	R-3 (Medium-strong)

5.9.4 Rock Mass Rating (RMR):

The Rock Mass Rating (RMR) was evaluated by examining a solitary exposed rock slope at 2-3 locations to guarantee accuracy. It has been observed that each of these locations has been designated as Good because of the presence of a substantial rock mass. The RMR values fall within the range of 66 to 67, indicating that the rock in the sliding area is classified as Class II and is in satisfactory condition as calculated in **Table 5.5**.

5.10 Slope Stability Analysis:

The stability assessment has been carried out using the two methods, i.e. SMR and Kinematic analysis.

5.10.1 Slope Mass Rating (SMR):

SMR values are calculated by using the technique by Romana (1985) to assess the stability of potentially-failing rock slope and to provide suggestions of effective protection measures as shown in table 5.5.

The SMR value of the rock mass within the study area varies between 22.00 to 76.40, suggesting the rock slope ranges from Bad (Class IV) to Good condition (Class II) (**Table 5.6**).

As per the SMR assessment, the rock slope exposed along the toe falls under Class-II i.e. Good category. The recommended support measures as per SMR for Kanganidhar landslide zone is given in **Table 5.7**.

Table 5.5: Calculated RMR_{basic} for 02 locations at site (After Bieniawski; 1989).

Rock slope	UCS (MPa)	RQD (%)	Spacing (mm)	Condition of discontinuities					GW condition	RMR	Class	Description
				Persistence (m)	Separation (mm)	Roughness	Infilling (mm)	Alteration/Weathering				
	25	91.9	150	1	0.1-1	Slightly rough	Clay	slightly weathered	Dry			
Rating	4	20	8	4	4	3	4	5	15	67	II	Good
	25	91.9	70	2	0.1-1	Slightly rough	Clay	slightly weathered	Dry			
Rating	4	20	5	4	4	3	4	5	15	65	II	Good

Table 5.6 Calculation of Slope Mass Rating (SMR) values

Location	Joint sets/Dat a (J1,J2,J 3)	RMR value	Slope morphometry	Mode of failure	Trend of intersec tion plane	α_j	α_s	α_i	P (α_j - α_s)	W(α_i - α_s)	F1	β_j	β_s	β_i	P/W (β_j or β_i)	F2	P(β_j - β_s)	W(β_i - β_s)	P/W(β_i - β_s)	F3	F 4	SMR= RMR+(F1*F2*F3)+ F4	SMR CLAS S	Description
1	55°/260°	67	70/ N260E	Planar	55°/260°	0	260	260	0	0	1		70	55	55	1	0	-15	-15	-60	15	22	IV	Bad
	40°/110°			Wedge	36/N201	201	260	0	0	59	0.15	36	70	0	36	0.85	-34		-34	-60	15	74.35	II	Good
2	40°/110°	65	70/ N260E	Planar	40°/110°	0	260	110	150	0	0.15		70	40	40	0.85	0	-30	-30	-60	15	72.35	II	Good
	50°/260°			Wedge	27/N194	194	260	0	0	66	0.15	26	70	####	26	0.4	-44		-44	-60	15	76.4	II	Good

Table 5.7 Description of suggested support (Romana; et al, 2003) as per calculated SMR values

Rock slope	Class	Rock mass description	Stability	Failure Mode	Probability of Failure	Suggested Support (Romana; et al,2003)	Recommended support methods based on the field condition
1	IV	Bad	Unstable	Planar	0.6	Re-Excavation wall, Surface Drainage, Deep Drainage, Shotcrete, Dental concrete ribs and/or beams, Toe walls.	Shotcrete
1,2	II	Good	Stable	Planar and Wedge	0.2	Bolts, Anchors Toe Ditch, Toe or Slope fences,Nets	Bolts

5.10.2 Kinematic Analysis:

Kinematic analysis has been carried out at 02 RMR/SMR locations with a view to find out different modes of failures. The joint sets recorded at the site have been plotted on stereo net with angle of friction Φ taken based on RMR scheme (Bieniawski, 1979) which provides us a fair idea about the shear strength of rock mass based on the structural data's. Based on the analysis, it has been observed that 02 locations show failure condition- planar and wedge failure. Hence, both planar and wedge mode of failures have been observed in the field, which are corroborated by the kinematic checks.

The rock slopes have majority three sets of joints whose structural data has been collected by extensive field work in the study area. The valuable data of the structural discontinuities of rock mass was then kinematically analyzed to ascertain the possibilities of failure at various locations using Dips software. Most of the rock slopes appear stable on date of field observation but may be prone to slope failure as kinematic analysis performed subjected to any slope modification or naturally due to gravity. The different types of failure observed are explained in detail below. The detailed kinematic analysis of rock slopes of study area is shown in **Figure 5.12** and **Figure 5.13**.

Locations of the kinematic checks at landslide is given in **Table 5.8**.

Table 5.8: Locations of the kinematic checks.

Locations Slope & Dir	Joint sets	Intersection of J	Plunge Amou	Plunge Direc	Mode of Failure	
					Planar	Wedge
1. 70°/260°	J ₁ =40°/N110° J ₂ =55°/N260° J ₃ =75°/N280°	(J ₂ *J ₃)	36°	201°	J ₂ =55°/N260°	J ₂ *J ₃
2. 70°/260°	J ₁ =40°/N110° J ₂ =50°/N260° J ₃ =80°/N275°	(J ₂ *J ₃)	29°	194°	J ₂ =50°/N260°	J ₂ *J ₃

a. Planar Failure:

The failures in the rock slopes are generally controlled by structural discontinuities which act as a plane of weakness to induce movements in the study area. Unfavorable orientation of the moderately dipping J₂, which is more or less parallel to slope showing planar failure at some location. **Figure 5.12** demonstrate the mutual geometric relations between the topography and the most vulnerable discontinuity through stereographic projections at different slope angle.

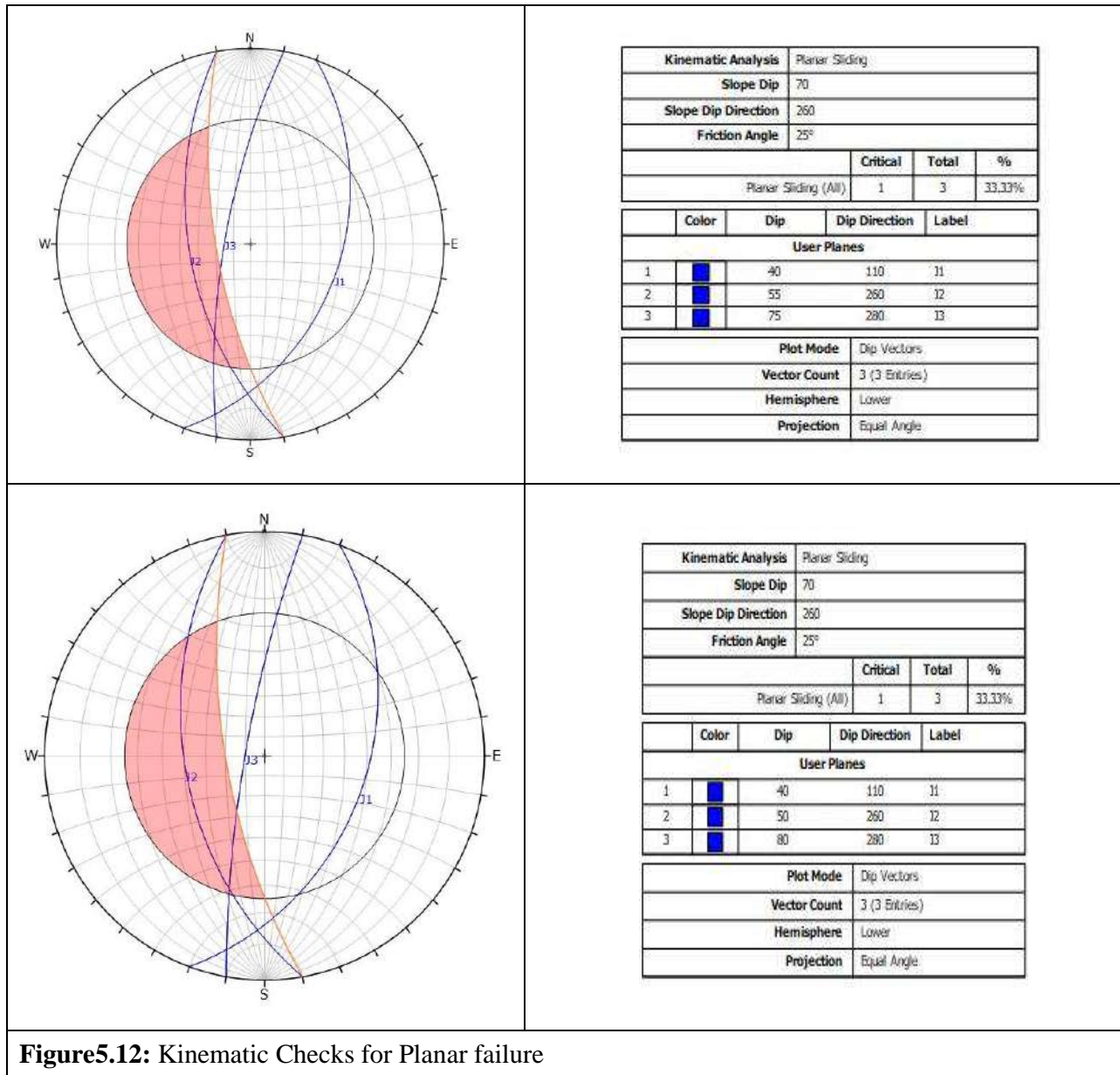

b Wedge Failure:

The intersection of planes of J₂ and J₃, (J₂∧J₃) forms unstable minor wedges, along Day lighted slope. The studies demonstrate the mutual geometric relations between the topography and the intersection discontinuity through stereographic projections as shown in **Figure 5.13**. In location 1 and 2, wedge failure is contributed by both J₂ and J₃.

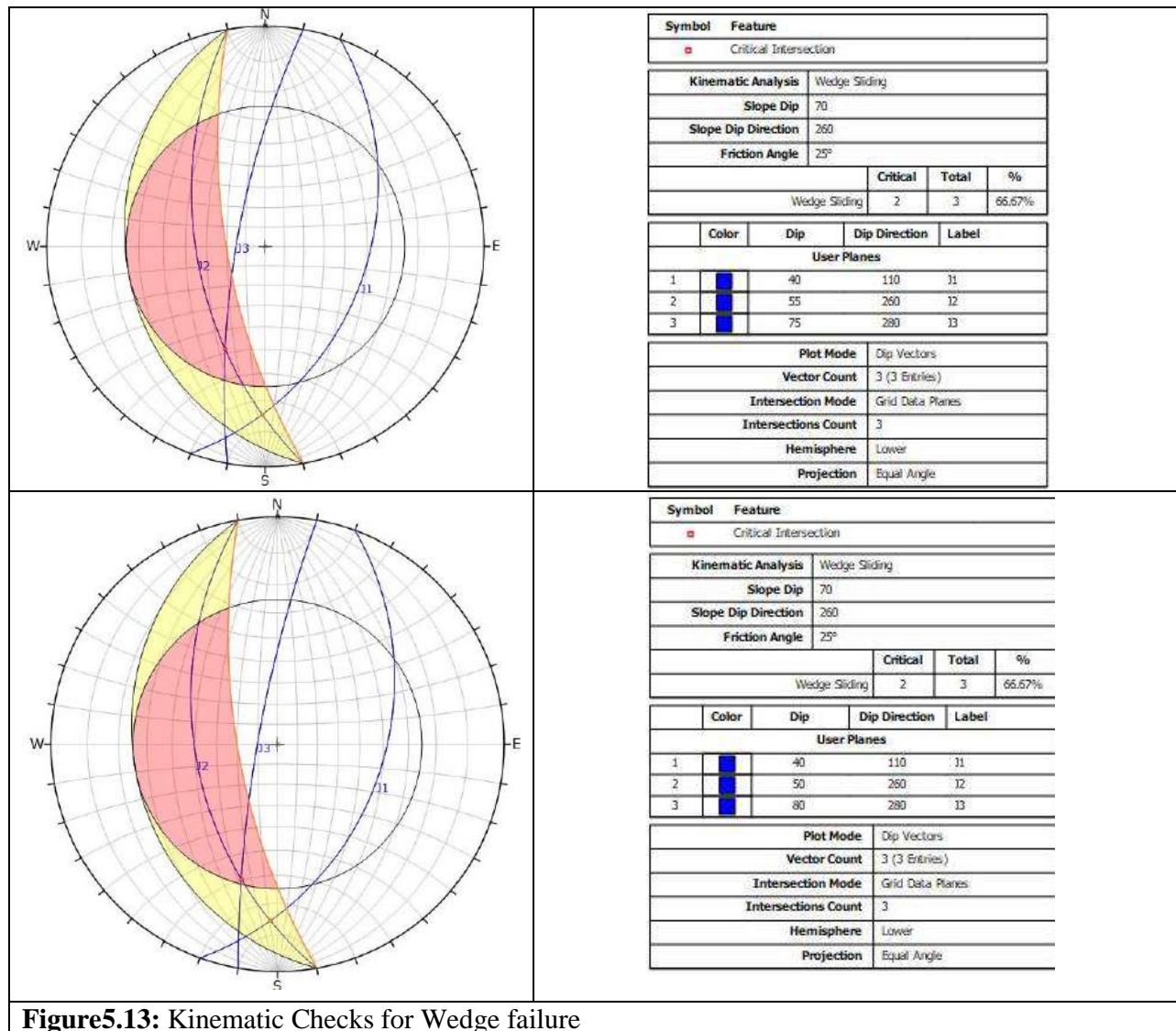

Figure 5.13: Kinematic Checks for Wedge failure

5.10.3 Results of Kinematic Checks

From the kinematic analysis, it is found that joints have played minor role in the failure of the rock mass at the site. Unfavorable orientation of the moderately dipping J_2 , which is more or less parallel to slope showing planar failure. The intersection of planes of J_2 and J_3 forms minor wedges, which are getting day lighted. Hence, both planar and wedge mode of failures have been observed in the field, which are corroborated by the kinematic checks. No joint is liable for toppling mode of failure.

5.10.4 Overall Stability Assessment

From the results of the SMR and kinematic analysis overall is assessed as unstable zone.

5.11 Geotechnical properties of the rock sample:

The geotechnical parameters of the rock are important factor which played essential role in the failure of the slope/formation of slide. However, no rock sample has been collected from the landslide for geotechnical analysis, since the distressed slope is dominated by debris material.

5.12 Discussions:

Kanganidhar landslide is located on the right bank of Suketi *Khud* along Mangwai – Rewalsar road. The elevation of the study area ranges from El ± 920 m to El ± 880 m. The dimensions of the slide were 30 m in height and 80 m in width, affecting nearly 80 meters of the National Highway road. The active scarp is very steep exposing loose unconsolidated debris material of undifferentiated quaternary deposit.

Morphometrically, the landslide site is located on a steep (65° to 75°) slope. After the landslide, the slope at the slide scar becomes modified further and is extremely steep (80°).

The slide is a led to the creation of zone of depletion in upper catchment. The detached debris material form a typical accumulated cone shaped debris deposit at the NH on the downslope.

Three sets of joints are recorded along the exposed rock mass. J₁ is a moderately dipping joint which is sub parallel to the slope face (Valley dipping). J₂ with its dip amount varying from 40°-65°. J₃ is a sub-vertical joint which dips against slope face (hill ward dipping). J₁ have potential for planar failure while J₁, J₂ & J₃ intersect each other, thus giving rise to form wedges having potential for failure on the slope profile.

A total nos. of 2 undisturbed soil samples were collected. The dry density value of soils samples varies from 15.00 kN/m³ to 16.32 kN/m³ wet density value of the soil samples varies from 16.12 kN/m³ to 17.60 kN/m³ The sample value indicates that the soil at this site is of loose, cohesionless sand and gravel. The moisture content of slide varies from 7.44 % to 7.79%. The NWC of the slide shows comparatively good packing as it contains lower moisture and indicates/expected to have lesser compaction in future. The specific gravity ranges from 2.60 and 2.49 and depicts the lack of heavy substances and may contain organic clay. The permeability of the soil sample varies from 2.5×10^{-4} to 2.6×10^{-4} i.e. It falls under medium to fine sand category.

Average value of Jv in basalts is 07-11 and RQD is 91.9%, RMR varies from 65 to 67 indicating the rock exposed at the slide zone is Class II and falls in Good Condition The SMR value of the rock mass within the study area varies between 22.00 to 76.40, suggesting the rock slope ranges from Bad (Class IV) to Good condition (Class II).

5.13 Slope stability analysis

Slope stability analysis is performed to assess the safety factor of potential and probable slope failures. The slope stability analysis was conducted for the central section of the zone and the FOS value closest to the field observations was considered as the final value.

The data incorporated to carry out the stability analysis is specified in **Table 5.8(a)**.

Table 5.8(a): Soil properties of Kanganidhar

Sl. no.	Soil properties	
1	Slope Height	35 m
2	Angle	70°
3	Cohesion	6.2 KPa
4	internal friction angle	31°
5	Dry Density	16.32 KN/m ³
6	wet density	17.6 KN/m ³

With the Circular Failure Chart (CFC), FOS is computed across several groundwater flow schemes to adjust the pore water pressure in the subsurface and stresses due to water present in tension fractures i.e. fully drained at 0% Groundwater condition to completely saturated slope due to heavy water recharge. The FOS at various ground water conditions is tabulated in Table 5.8 (b)

Table 4.10(b): Soil properties of Kanganidhar Hill

SLOPE Factor of Safety Calculated by Circular Failure Chart by Hoek and Bray Chart		
Ground water Condition	Calculated FOS Dry	Calculated <i>FOS Wet</i>
100%	0.429	0.423
75%	1.036	1.085
50%	1.114	1.176
25%	1.143	1.190
0%	0.429	0.423

These results indicate that the slope is unstable and has reached the failure condition as FOS for both wet and dry lies below 1 when completely saturated. The chart for FOS calculation at fully saturated is given in **Figure 5.13 (b)**.

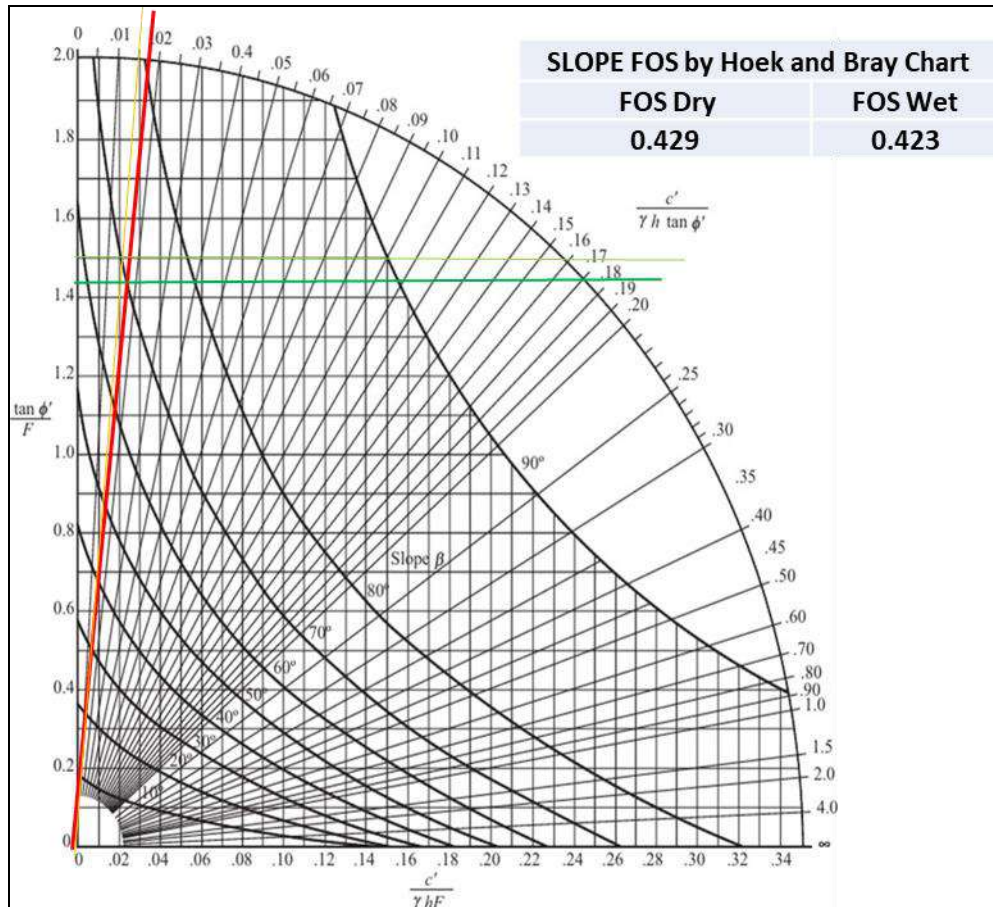

Figure 5.13 (b) Calculation of Factor of Safety at Kanganidhar Hill Landslide by Circular Failure Chart

5.14 Contributing and Causative Factors

To pinpoint the failure mechanism, it is essential to clearly pinpoint the contributing and causative factors specific to a particular site. Efforts have been made to identify both the natural (geo-genic) and human-induced (anthropogenic) factors that contribute to and cause the occurrence of this landslide.

5.15 Geo-genic Contributing Factors

1. The factors that have been identified as geo-genic contributors to the instability in the landslide zone include a steep slope with an inclination of approximately 55°-60°, which has further facilitated the rapid movement of debris material and erosion of the surrounding hill slope.

2. Another factor is the over saturation of water within the fragile and loose material of the slope forming material, particularly during heavy precipitation.

3. Additionally, the presence of open joints in the area has provided a pathway for the entrance of surficial water, which has contributed to the development of active stress in the form of piezo metric head/stress.

5.16 Anthropogenic Causative Factors

The occurrence of slope instability incidents/failures can be attributed to a range of human activities, such as the alteration or removal of hill slopes and the absence of proper drainage systems to divert domestic waste away from areas prone to landslides.

5.17 Type of Slide

This type of failure occurs when the soil mass above a certain depth rotates around a point or line, causing the ground to collapse or slide. In this case, the rotational failure was likely triggered by factors such as excessive rainfall, poor soil composition, or steep slopes. The presence of tension cracks, slumping, and other signs of movement further support the conclusion that rotational failure was the cause of the collapse. Understanding the mechanisms behind this type of failure is crucial for implementing effective mitigation measures to prevent similar incidents in the future.

From the field observations, it is clear that the failure is a typical example of rotational failure.

5.18 Recommendation/remedial measures

The landslide is situated on the right bank of the Suketi *Khud*. Following the incident, the slope has undergone significant erosion and incision, resulting in the formation of a steep slope. The active scarp is steep and exposes loose unconsolidated debris material from undifferentiated quaternary deposits, as well as a few erratic exposures of Mandi Volcanics.

To address the landslide issue in this area, several remedial measures are recommended based on detailed field observations and analytical results.

1. It is advised to construct a lined drainage parallel to the contour in the crown portion at an elevation of El±920 m. This drainage should be used to join and discharge domestic water and other drains from the upslope, preventing water saturation in the debris material.

2. The area above the crown of the landslide should be closely monitored for the development of any new ground cracks. These cracks should be sealed by filling them with clay or other impervious fill, such as Bentonite, to reduce permeability and prevent surface water from accumulating in the area.
3. The steep slope should be modified into the benches in consultation with design engineers for specification with the use of adequate retaining wall structures that incorporate weep holes. This will help in stabilizing the slope and preventing further erosion.
4. The unstable slope mass may be filled with reinforced soil fill to increase the shear strength of the soil. The type and quality of reinforced elements may be designed with the concerned design engineers.
5. The slide area should undergo bio restoration in consultation with a botanist. This can be accompanied by the installation of wire netting and debris fall barriers to enhance stability.
6. When reconstructing breast and retaining structures along the road, it is crucial to incorporate adequate filters and drainage systems, especially when dealing with debris-filled masses. These measures will contribute to the overall stability and safety of the area affected by the landslide.

5.19 INSTRUMENTATION

Landslide monitoring systems utilize crack and joint meters to precisely monitor the displacement and opening of cracks within rock masses, buildings, and structures. These instruments play a crucial role in detecting potential instability and providing early warnings to prevent disasters.

5.19.1 Subsurface Instruments: -

- 1) Inclinometers are strategically placed at various points along the retaining wall or building where they are most affected by external forces. These devices monitor any variations in the slope angle near potential weak points such as cracks and areas prone to rotational displacement.
- 2) Piezometers are used for monitoring pore water pressure variations in the landslide area.

References:

1. Attewell P.B. and Farmer, I.W. (1976). Principles of Engineering Geology.
2. Bieniawski, Z. T. (1973). Engineering classification of rock masses. Trans. S. Afr. Inst. Civ. Eng; 15.335-44.
3. Bieniawski, Z. T. (1989). Engineering rock mass classifications: a complete manual for engineers and geologists in mining, civil, and petroleum engineering. John Wiley & Sons.
4. BIS Code 14496 (Part-2) (1998) Preparation of Landslide Hazard Zonation Maps in Mountainous Terrains-Guidelines.
5. Bishop, A.W. (1955). The use of the slip circle in the stability analysis of slopes. Geotechnique, 5 (1), 7–17.
6. Central Ground Water Board (2013), Ground Water Information Booklet Mandi District, Himachal Pradesh, Ministry of Water Resources, Government of India
7. Deere D.U., and Miller R.P. (1966). Engineering classification and index properties for intact rocks. Tech Rep Air Force Weapons Lab, Wright-Patterson Air Force Base, p 301.
8. Deere, D.U., Hendron, A.J., Patton, F.D., and Cording, E.J. (1967). Design of surface and near surface construction in rock, 8th U.S. Symposium on Rock Mechanics: Failure and breakage of rock: New York, Society of Mining Engineers, American Institute of Mining, Metallurgical, and Petroleum Engineers.
9. Folk, R.L. (1968) Petrology of Sedimentary Rocks. Hemphill's, Austin Texas, 194 p.
10. Hoek E., and Bray J.W. (1981). Rock Slope Engineering, Institution of Mining and Metallurgy, Taylor & Francis; Revised 3rd edition, London.
11. IS 13365 (Part 3) 1997: Quantitative Classification System of Rock Mass – Guidelines. Part 3 Determination of Slope Mass Rating, Government of India.
12. IS 14680 (1999): Landslide Control – Guidelines, Government of India.
13. Law, K. T., & Lumb, P. (1978). A limit equilibrium analysis of progressive failure in the stability of slopes. Canadian geotechnical journal, 15(1), 113-122.
14. Look, B. G. (2014). Handbook of geotechnical investigation and design tables. CRC Press.
15. McMohan, C. A. (1882) On the traps of Drang and Mandi in the Northwestern Himalaya. Bec. Geol. Surv. India vol. Xv, pp. 34-51
16. National Centre for Seismology Ministry of Earth Sciences, Government of India, A Preliminary Report of August 05th, 2023 Hindu Kush Region, Afghanistan Earthquake (M 5.8) https://seismo.gov.in/sites/default/files/pressrelease/Earthquake_report_Afg_5.8.pdf, (Report No.: NCS-NSN-EPG-05).
17. Palmstorm, A., (1982): The volumetric joint count- A useful and simple measure of the degree of rock mass jointing. *IAEG Congress*, New Delhi, 1982. Pp. V.221-V.228.
18. Raghuvanshi, T.K., (2019). Plane failure in rock slopes – a review on stability analysis techniques. *J. King Saud Univ. Sci.* 31 (Issue 1), 101–109
19. Romana M., Seron J.B., Montalar E., (2003). SMR Geomechanics classification: Application, experience and validation. *ISRM 2003- Technology roadmap for rock mechanics*, South African Institute of Mining and Metallurgy.
20. Romana, M. (1985): A geomechanics classification for slopes: Slope Mass Rating. *Comprehensive rock engineering*, Vol. 3 Pergamon Press.

21. Setti, D.N. (1960-61). A report on the systematic geological mapping, in parts of the Chichiot, Mandi and Sundernagar tehsils, of Mandi district, Himachal Pradesh.
22. Sidle, R.C.; Pearce, A.J.; O'loughlin, C.L., 1985: Hillslope stability and land use. Water Resources Monograph 11: 140 pp
23. Singh, I. and Kulshreshta, S.K, Geoenvironmental appraisal of Mandi district F.S. 2000-2001.
24. Spencer, E. (1967). A method of analysis of the stability of embankments assuming parallel interslice forces. *Geotechnique*, 17(1), 11-26.
25. Srikantia S V 1977 The Sundernagar Group: its geology, correlation and significance as stratigraphically deepest sediment in the Peninsular of Lesser Himalaya;*J. Geol. Soc. India* 18 7–22
26. Srikantia S.V and Bhargava O.N (1998) Geology of Himachal Pradesh. Pub. Geological Society of India Bangalore.
27. Srikantia S.V. and Bhargava O.N. (1971) A note on the subsidence sink-hole at Runjh,district Mandi, Himachal Pradesh
28. Srikantia, S. V. and Sharma, R. P. (1972) The Precambrian salt deposits of the Himachal Pradesh Himalaya — its occurrence, tectonics and correlation;*Himalayan Geol.* 2 22–38
29. Srivastava, K.N. A Report on the investigation of the reported subsidence of the hill slopes carrying the penstock to the Joginder-Nagar Power House, (Field Season 1966-67 & 1967-68)
30. Vadakkedath, R. and Biswal, M. (2016). Macro-scale (1:50000) National Landslide Susceptibility mapping in parts of toposheet nos. 53A/13 & 14, parts of Kullu and Mandi districts, Himachal Pradesh. FS: 2015-16. GSI Unpublished Report
31. Vishwa B. S. Chandel & Karanjot Kaur Brar (2010) Seismicity and vulnerability in Himalayas: the case of Himachal Pradesh, India, *Geomatics, Natural Hazards and Risk*, 1:1, 69-84
32. Voulgari C., 2015. An experimental model for slope subject to weathering. Int'l. Symp. Geohazards and Geomechanics.
33. Wagner, A.A. (1957), The use of the unified soil classification system by the Bureau of Reclamation, *proc.4th Int. Conf. Soil Mech.and Found.Engg.*, London, I, pg125-134.
34. Wentworth, C.K. (1922) A Scale of Grade and Class Terms for Clastic Sediments. *Journal of Geology*,30,377-392.<https://doi.org/10.1086/622910>
35. www.imd.gov.in & <https://weathershimla.nic.in>
36. Zienkiewicz, O. C., Humpheson, C., & Lewis, R. W. (1975). Associated and non-associated visco-plasticity and plasticity in soil mechanics. *Geotechnique*, 25(4), 671-689.

भारत सरकार/Government of India
खान मंत्रालय/Ministry of Mines
भारतीय भूवैज्ञानिक सर्वेक्षण/ Geological Survey of India



हिमाचल प्रदेश के मंडी जनपद में तारना हिल्स, सर्काघाट तथा धरमपुर क्षेत्र में
हुए डेब्रिस भूस्खलन पर प्रतिवेदन

**REPORT ON THE PRELIMINARY ASSESSMENT OF DEBRIS SLIDE AT
TARNA HILLS, SARKAGHAT AND DHRAMPUR AREAS OF MANDI
DISTRICT HIMACHAL PRADESH**

टोपोशीट सं: 53A/9,10.13,14/Toposheet No.: 53A/9,10.13,14

मद संख्या: एम.4 ईजीजी/सी/एन.आर./एस.यू.पी. एच. पी. 2023/46620

Item Code No.: M4EGG/C/NR/SU-PHP/2023/46620

कार्यसत्र 2023-24
Field Season 2023-24

द्वारा
श्रेयशी महापात्रा, वरिष्ठ भूवैज्ञानिक
वांग्शितुला ओजूकुम, भूवैज्ञानिक

By
Shreyasi Mahapatra, Senior Geologist
Wangshitula Ozukum, Geologist

मिशन-IV
MISSION-IV

राज्य इकाईपंजाब :, हरियाणा एवं हिमाचल प्रदेश / State Unit: Punjab, Haryana and Himachal pradesh
उत्तरी क्षेत्र / Northern Region
चंडीगढ़ / Chandigarh

अक्टूबर, 2023
October, 2023

**REPORT ON THE PRELIMINARY ASSESSMENT OF DEBRIS SLIDE AT
TARNA HILLS, SARKAGHAT AND DHRAMPUR AREAS OF MANDI
DISTRICT HIMACHAL PRADESH**

Item code No M4EGG/C/NR/SU-PHP/2023/46620

Field Season: 2023-24

By

Shreyasi Mahapatra, Senior Geologist & Wangshitula Ozukum, Geologist

INTRODUCTION

Himachal Pradesh, a state renowned for its heavy monsoon precipitation, grapples with a heightened susceptibility to landslides in its geologically young and unstable Himalayan ranges. The region's vulnerability to slope failure has worsened in recent times due to human activities like deforestation, road construction, terracing and shifts in agricultural patterns.

In the 2023 monsoon season, Himachal Pradesh faced a notable increase in landslides, resulting in the loss of lives and damage to properties in different areas. Mandi district, in particular, saw several occurrences of landslides. In response to letter No. DC/MAN/DDMA/DEOC/3793-96 dated 29th August 2023 from DC, Mandi, HP, the Geological Survey of India (GSI), being the nodal agency for carrying out landslide related studies in India deployed a team of geoscientist from Engineering Geology Division of GSI Chandigarh, NR. This GSI team conducted a preliminary field visit to the affected areas on 04th September 2023, in coordination with the Himachal Pradesh State Disaster Management Authority (SDMA) and district authorities.

During the course of preliminary field work, necessary geological/geotechnical data in and around the affected area has been collected and attempts were made to know probable causes of slide. Besides, damage assessment has also been done and accordingly suitable remedial measures has been suggested.

LOCATION AND ACCESSIBILITY

The Mandi district of Himachal Pradesh is bounded between 31°13'50'' and 32°04'30'' north latitude and 76°37'20'' and 77°23'15'' east longitude. The Kangra district lies towards the northwest, Hamirpur & Bilaspur in the west, Arki tehsil of Solan district in the south, Shimla district in the south-west and Kullu district in the east. Mandi district covers an area of 3950 sq km and lies in the middle portion of H.P The landslide affected area, as informed by SDMA, HP and District Authorities, Mandi, are as below.

- a. Tarna Hills, Mandi
- b. Juccain, Sarkaghat, Mandi

- c. Tathi, Sarkaghat, Mandi
- d. Riyur area, Dharampur, Mandi
- e. Narera Cloudburst, Dharampur, Mandi
- f. Phagwaon, Dhanotu, Sundernagar, Mandi

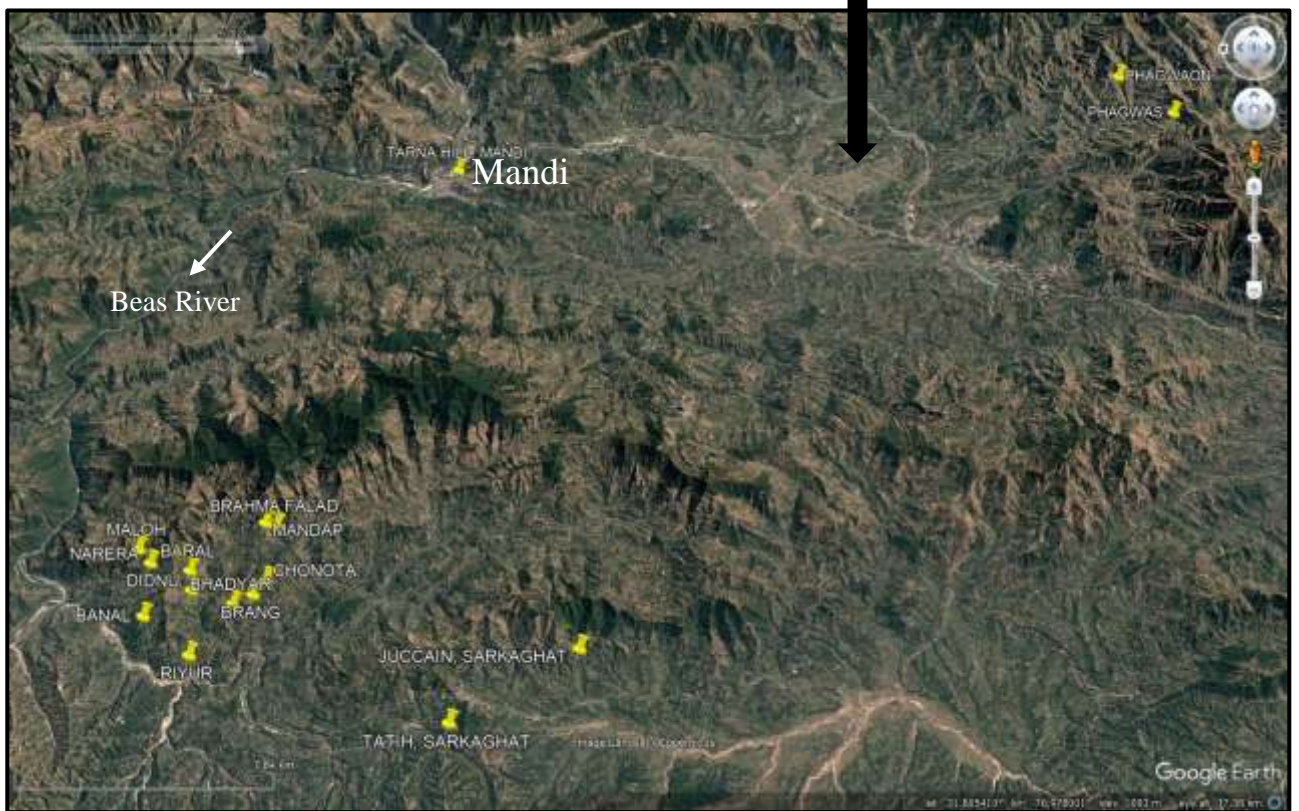
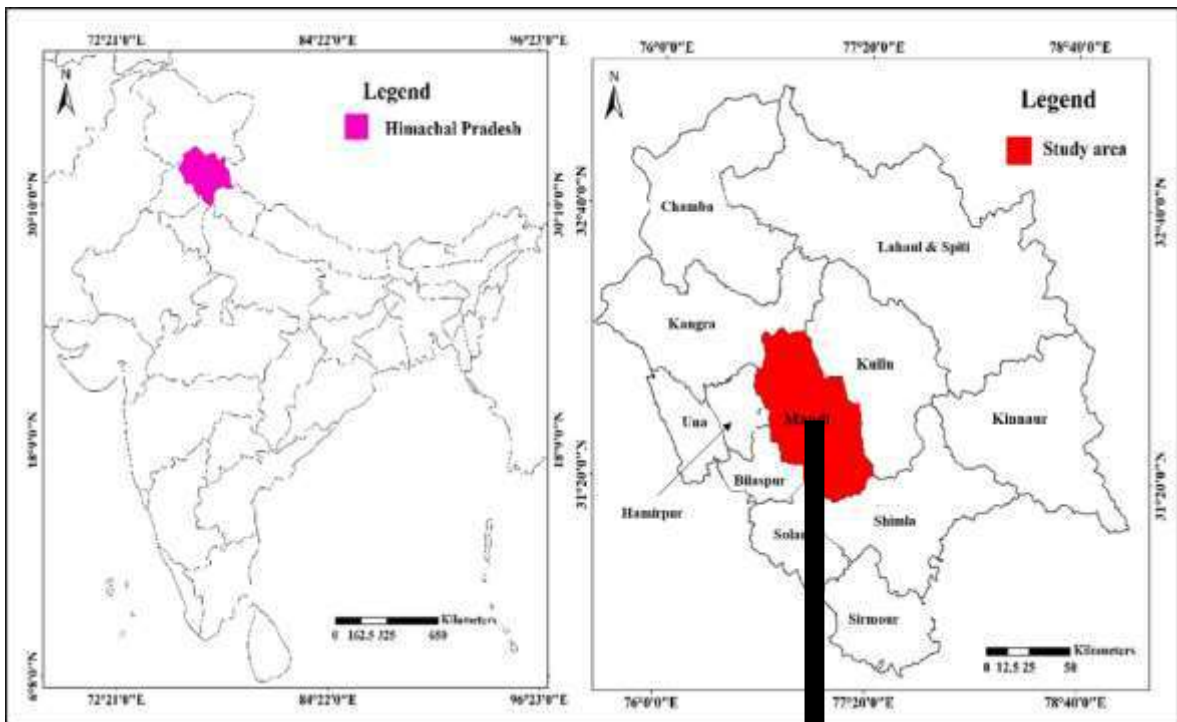

Figure 1: Location map of the landslide locations in Mandi district, Himachal Pradesh. (Satellite Imagery from Google Earth Pro.)

The location map of the landslide effected areas is shown in Figure 1. The general elevation of areas affected by the landslide incidences ranges from 700m to 1400m msl.

Mandi is one of the largest cities of Himachal Pradesh and is well connected to all major cities of Himachal Pradesh, Punjab and Delhi. The area is approachable by all-weather road and can be accessed from Chandigarh and Shimla via Chandigarh - Mandi - Manali NH-21 up to Mandi and Shimla - Bilaspur -Mandi respectively. The nearest airport to Mandi is the Kullu Airport at Bhuntar, about 75 km from Mandi city. This is a small domestic airport. There is currently no railway connectivity to Mandi. The nearest railway station currently is the Jogindernagar Railway Station (Narrow Gauge) almost 50 km from the Mandi city.

CLIMATE AND RAINFALL

The climate of Mandi is composite having hot summers and cold winters. Mandi generally experiences rainfalls during end of summer season. Mandi city falls in the lower most climatic zone of the Himalayas. These regions enjoy a Wet-sub temperate climate of the foothills (450–900 m) as against the Dry-cold alpine climate with snow fall at higher altitudes (2400 m – 4800 m). Temperatures typically range from 6.7 to 39.6 °C (44.1 to 103.3 °F) over the course of a year. The average temperature during summer is between 18.9 and 39.6 °C (66.0 and 103.3 °F), and between 6.7 and 26.2 °C (44.1 and 79.2 °F) in winter. Monthly precipitation varies between 25.4 millimetres (1.00 in) in November to 228.6 millimetres (9.00 in) in August. It is typically around 58.3 millimetres (2.30 in) per month during winter and spring and around 101.6 millimetres (4.00 in) in June as the monsoon approaches. The average total annual precipitation is 832 millimetres (32.8 in) (CGWB, 2013)

In the year 2023, the state witnessed an unprecedented high rainfall, intestifying both landslide and erosion activities throughout the city. The heavy precipitation is supplemented by quantifying the total rainfall recorded at different locations, based on IMD data analysis during the period 2014- 2023, from April to August. Based on the plotting of IMD data, it was observed that during 2023, heavy rainfall was recorded at all locations, with the total recorded rainfall varying from 186 mm, 254 mm, 287 mm, 529 mm and 694 mm respectively, from April to August 2023, and was considerably on the higher side in comparison to the total rainfall during the preceding years in Mandi district. Further analysis also revealed that although the total rainfall has increased in each month, the number of rainy days have decreased in each month, reflecting heavy spells of rainfall in 2023.

During the initial week of July, the region experienced extended periods of intense, unrelenting

spells of torrential rainfall, saturating the soil. This pre-soaked condition was compounded by another spell of heavy persistent rainfall over the weekend of August 13-15, 2023, which caused havoc in the hilly region of Mandi (<http://hydro.imd.gov.in>).

GEOMORPHOLOGY AND SEISMICITY OF THE AREA

Mandi district presents an intricate mosaic of mountain ranges, hills and valleys. It is primarily a hilly district with altitudes ranging from 550 m near Sandhol where the Beas River leaves the district, to about 3960 m msl near Kullu border. There is a general increase in elevation from west to east and from south to north. Master slope is south-westerly. The south western part consists of Siwalik ranges having scarp slopes.

There are few small intermontane valleys; located in the lesser Himalayan ranges, having an average altitude of about 790 m msl and have a general slope towards NNE. The valley floor is undulating and is marked by low hillocks and terraces fringing the hills and intervening low alluvial plain.

The Beas and Satluj Rivers form the major drainage system in the district. The River Beas and its tributaries, drain about 70% of the district area in the northern part, whereas the area in the south is drained by the River Satluj. The Suketi *khad* maintains a perennial flow, because of effluent seepage from groundwater. There are three important lakes in the district, namely Rewalsar, Prasher and Kamrunag.

The Mandi area is seismically very active and one of the deepest and most active intracontinental subduction zones on Earth, originated due to a collision between the Indian and Eurasian lithospheric plates at the western Himalayan margin. The preliminary fault plane solution derived from moment tensor inversion suggests a thrust fault.

In addition to the above, it is mention that the occurrence of earthquakes in the region is attributed mainly to the tectonic settings of Main Boundary Thrust (MBT), Main Central Thrust (MCT) and several local faults and geological demarcated lineaments. Mandi falls in seismic zone IV, which has been classified as high damage risk zone MSK VIII (Source: BMPTC Earthquake Hazard Map, HPSDMA website).

Three epicenters have been recorded in Mandi so far. The locations of the epic centre is given in the hazard map below in Fig 2 (Source: Natural Hazard Map of Mandi District, Himachal Pradesh, Geo Data Division, GSI, Chandigarh prepared from Seismotectonic Atlas, 1995).

As per the data of National Centre for Seismology (NCS), an earthquake of magnitude M 5.8 occurred on 5th August 2023, with its epicenter in Hindu Kush Region, Afghanistan. The

earthquake is widely felt in Himachal Pradesh, Jammu and Delhi-NCR region. Aftershocks events also occurred on 05th August and 06th August 2023. (NCS, Report No.: NCS-NSN-EPG-05)

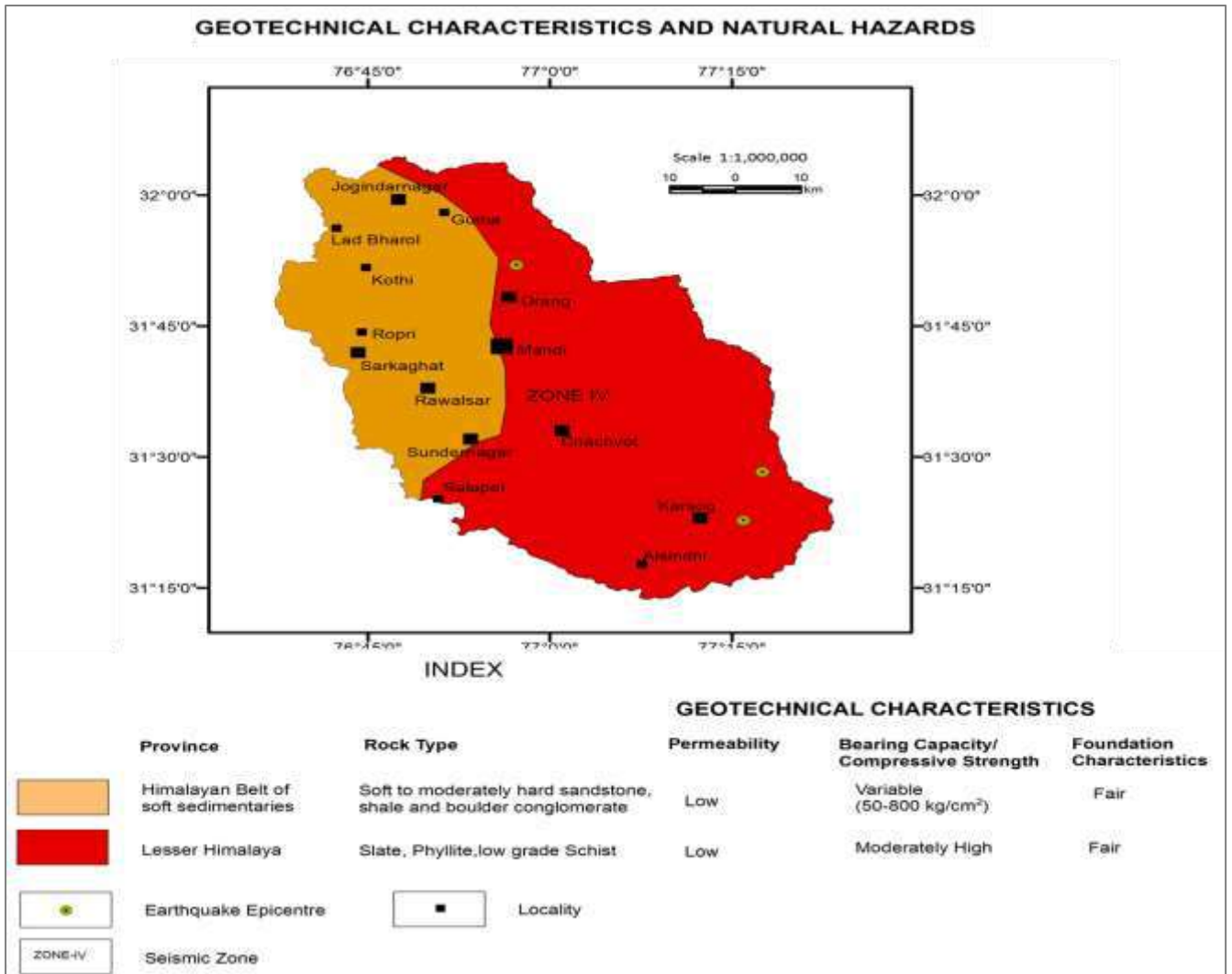

Figure 2: Natural Hazard Map of Mandi District, Himachal Pradesh, showing the epicenter locations as marked from Seismotectonic Atlas, 1995 (Source: Geo-data Division, GSI Chandigarh)

GENERAL GEOLOGY OF THE AREA

Geologically, the area is occupied by the rocks of Palaeo-proterozoic to Holocene age. The Paleoproterozoic rocks are represented by the Kullu, Vaikrita, Sunder Nagar Groups, the Mesoproterozoic comprises Shali Group and Neo-proterozoic includes the Manjir, Katarigali and Guma Formations. The Palaeogene and Neogene are constituted of the Sirmaur and Siwalik Groups respectively. Newer alluvium group of the Holocene age represents the Quarternaries.

The rocks in the area have undergone polyphase deformation NW-SE trending regional folds are responsible for repetition of various lithounits which at places are disrupted by thrusts or faults.

The area is marked by number of thrusts and faults of regional dimensions which include Palampur thrust.

Overall, the area is covered by a thick overburden comprising of moderately compacted soil and palaeo- debris material having an approx. thickness of 3-5m.

The Geological Map of the area and the landslide location under study is given in Figure 3.

THE LANDSLIDE INCIDENCE:

The details of the landslide incidence studies carried out at various sites are as below.

1. SUKETI *KHAD* BRIDGE LANDSLIDE, TARNA HILL, MANDI

The landslide zone is situated at coordinates 31.705220 N and 76.933442 E, along Mangwai Road on the left bank of Suketi *Khad* River. It is approximately 1.8 Km southwest from Mandi town and falls in Survey of India Toposheet no. 53A/14. The slide lies at an elevation of 860 m MSL. The dimension of the slide measures 70 m high and 50 m wide affecting nearly 30-m stretch of the Mangwai road causing significant disruption in vehicular traffic. The schematic diagram and the section of the slide is given below in Figure 4.

Since, the first week of August, 2023, the hill has displayed signs of structural deterioration due to continuous heavy rains in July, 2023. Consequently, residents vacated their houses as a precautionary measure. The situation worsened following relentless rains on 12th and 13th August, ultimately the hill gave way on 14th of August 2023. The slide resulted in the collapse of one building and substantial damage to several others. Fortunately, due to prompt action by district authorities, no casualties were reported. The pathway connecting the houses was obliterated by the slide, along with the drainage pipes/ channels. Notably, numerous diagonal cracks were observed on the walls and floors on the adjacent building indicating an enlarging nature of the slide.

These houses appears to be in unstable condition. In the crown portion of the slide, tension cracks trending N 80° were identified. These cracks were filled with clay and covered with impervious plastics sheets offering a temporary measure to mitigate the situation. The electric poles and trees have also been uprooted due to the slide. Three natural springs were observed at the crown portion of the slide as shown in figure below. The water from the domestic drains have been diverted to the nearest *nala*. Figure no. 5 shows the morphometry of the slide.

The observations revealed the landslide to be a debris slide, which is a deep rotational failure presently triggered due to slope saturation. The landslide is active with its toe terminating in mid hill part at the Mangwai Road. The area exhibits generally moderate to steep slope. The debris

slide is attributed to weakened slope debris due to water ingress and subsequent slope saturation by heavy rain.

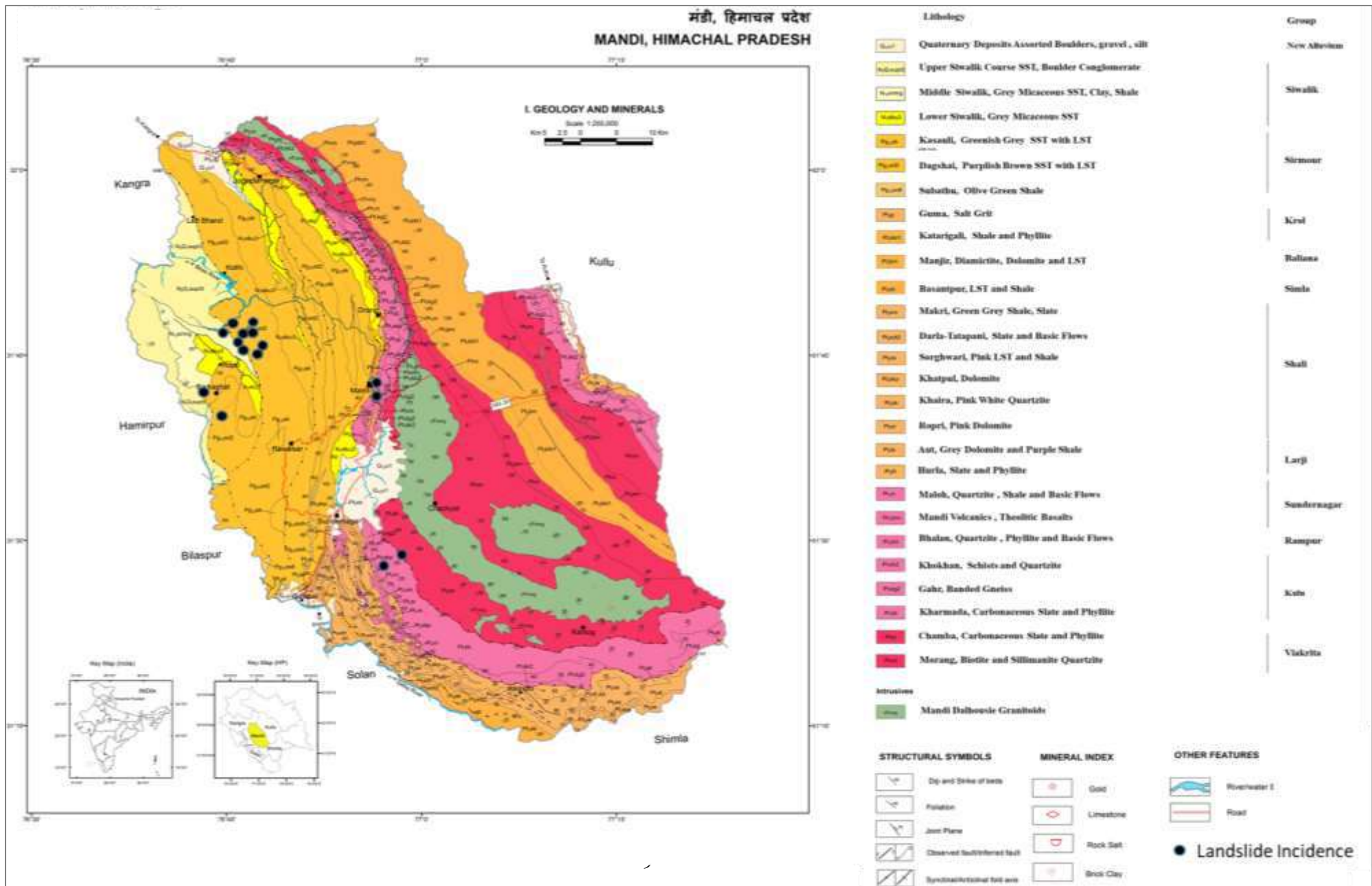

Figure 3: Geological Map of study area, Mandi District, Himachal Pradesh.

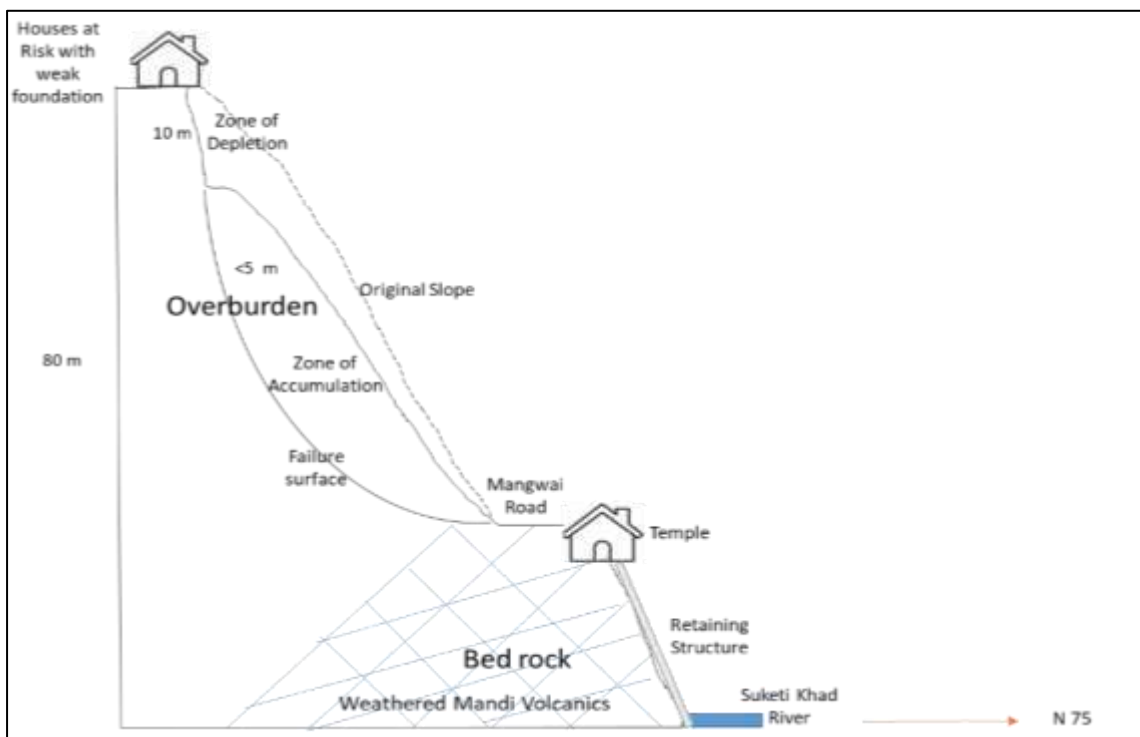
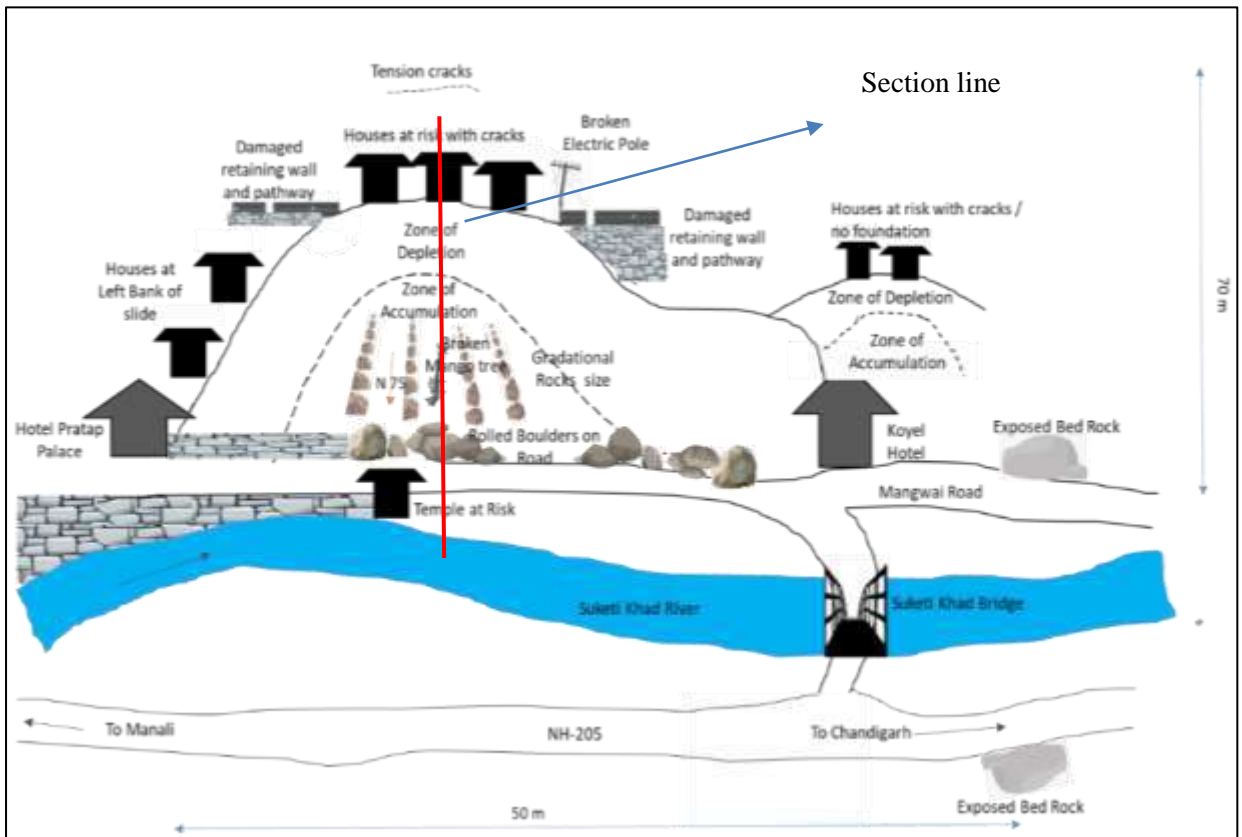

Figure 4: a) Schematic Diagram and b) profile section of the Tarna Landslide, Mandi District, Himachal Pradesh.



Figure 5 : Morphometry of Tarna slide near Suketi *Khad* bridge

The landslide area mostly comprises of basalt and quartz arenite of Mandi Volcanics of Sundernagar Group. The area is in close proximity to Kullu Thrust and Mandi-Sundernagar Thrust and hence the rocks are highly jointed and fractured. The Weathering index at the toe of the slide ranges from W_4 - W_5 and W_5 (ISRM, 1981a) near the crown portion. The area has already been identified as moderate landslide susceptibility zone by Geological Survey of India (GSI, 2018-2019). No out crop was observed on the slide area, however, outcrop was observed near the left bank of the slide. Three set of joints were observed. The details of the joints as observed at the site is tabulated in Table 1.

Joint	Strike	Dip Amount and Direction	Persistence (m)	Apperture (cm)	Hydrological Condition
J ₁	N350 ⁰	30°/N260°	<1	0.1	Dry
J ₂	N120 ⁰	70°/N210	<1	0.3	Dry
J ₂	N160 ⁰	85°/N250°	<1	0.2	Dry

Table 1. Details of joints at Tarna Hill area, Mandi District, Himachal Pradesh.

The presence of outcrop has provided adequate support to Koyal Hotel and thus it has suffered minimal damage. The hotel premises were checked thoroughly for any cracks/ damage. The structure seems stable without any signs of damage due to the slide. The debris material and other abandoned civil structures overhead need to be removed precariously to protect the hotel.



Figure 5 (a) showing Tarna hill debris slide material comprising of loose boulders of Sandstone of various sizes embedded in a matrix of silt to clay.

Figure 5 (b) showing debris slide on opposite of Tarna Hill Slide on National Highway.



Figure 5 (c) Cracks on floor and houses located at the crown of the slide.



Figure 5 (d) Showing unscientifically constructed civil structures over unconsolidated material.



Figure 5 (e) Ground cracks on the top sealed by clay and covered by plastic sheets

Figure 5 (f) Ground cracks trending N 10° on the crown of the slide

The salient features of the landslide have been enumerated below-

1. Landslide is a result of shallow rotational failure.
2. The slide is enlarging in nature and is confirmed by observing the development of ground cracks as well as cracks on the buildings of adjacent houses. Some cracks also developed on the 15th August after the incidence.
3. The causative cause of the landslide is due to oversaturation of the slope forming material along the slope due to two spell of continuous rainfall in the month of July and August 2023 which lead to increase in pore pressure within the soil reducing friction along the potential failure surfaces.
4. Unscientific construction of buildings with poor foundation has further worsened the condition.

Future Menace

The terrain generally exhibits moderate to steep valley slope. In view of presence of loose debris,

the stretch is seemed to remain unstable and required to be dealt carefully and scientifically.

Geoscientific Causes

The Geoscientific factors attributed to the cave-in of the road are as follows:

- 1) The steep slope having an inclination of approx. 45°-50° further facilitated the rapid movement of debris material and erosion of surrounding hill slope.
- 2) Flood like situation of the Suketi *Khad* river in month of July triggered toe cutting of the slope. The pillars and the retaining structures have also been damaged by the flood
- 3) Over Saturation of water within the fragile and loose material of slope forming material during heavy precipitation.
- 4) It was also observed that due to various anthropogenic activities like construction of buildings, civil structures and other infra-structure development activities in unplanned/less-planned manner, cutting/modification of hill slopes lead to possibilities of slope instability incidences/failures.

Recommendations

The following remedial measures have been suggested to contain the road to cave in further:

- i. Sealing of ground cracks wherever possible by impervious material (impervious clay, tar etc.) to restrict water infiltration. Area above the crown of landslide needs to be monitored for development of any new ground cracks. The cracks must be sealed either by filling them with clay or other impervious fill to reduce further permeability to ensure surface water does not pond in the area.
- ii. Several loose boulders present on the slope area between crown and Mangwai road corridor can be removed manually and modified slope in to terraces for multi levels using adequate retaining wall structure with a provision of weep holes.
- iii. Construction of proper lined drainage at the crown portion to intercept/collect surface run-off into distressed zone.
- iv. Ensuring construction of the Civil Structures strictly following building BIS codes.
- v. Site specific detail investigation should be carried out.

In addition to the slide near Suketi *Khad* Bridge, several landslides have been recorded in the Tarna Hills area. Notable incident occurred near the HPPWD Circuit house in Mandi. The slide zone (latitude 31.700833 N and 76.92722 E longitude) falls in Survey of India, Toposheet no 53A/14. This slope failure was reported on 14th August 2023, resulting in the complete collapse of a building and causing foundational damage to multiple structures. An uphill track towards the crown was made by the authors to assess the ground cracks. Figure 6 (c) depicts the tension cracks above the slide area.

The dimensions of the slide are approximately 80 m in length and 80 m in width.

The observations suggest that this landslide is a debris slide, characterized by shallow rotational failure which was triggered by intense rainfall which lead to over saturation of the underlying slope forming material. The landslide is active and is progressively widening. The pathway has developed numerous wide cracks which are continuously sinking as on date of study. The maximum subsidence has been measured to be >2m. These cracks are depicted in figure 6 (d). The pathway connecting the houses completely caved in due to the slide. The area features generally steep slope. The schematic diagram of the slide is given in Figure 6 (a).

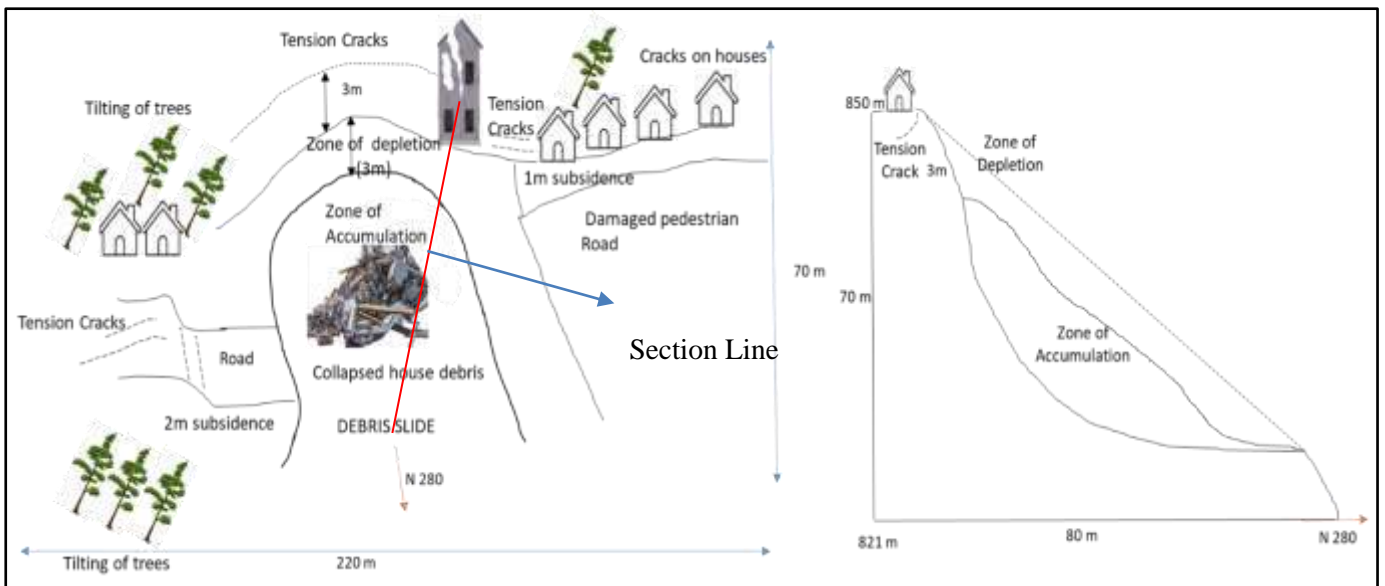

Figure 6: a) Schematic Diagram and section of the slide near Circuit house, Mandi District, Himachal Pradesh.

The prospective view of the slide is given in Figure 6 (b)



Figure 6: (b) Prospective view of the slide near Circuit house, Mandi District, Himachal Pradesh



Figure 6 (c) showing Tension cracks above slide area. Cracks nearly 2 m deep and 3 m in length.



Figure 6 (d) showing damage to roads, active subsidence > 2-3m, cracks 26 cm wide, 3 m long and 40 cm deep.



Figure 6(e) showing tilting of trees, cracks and subsidence in road indicating shallow continuous downward motion	Figure 6 (f) showing damage and cracks on buildings/ floors on left bank of slide
---	---

Field observations and causative factors:

- i. The heavy rainfall spell had led to the sliding of this overburden cover comprising of soil and rock fragments.
- ii. A steep slope (approx. 60°-70°) has been observed at the landslide affected area.
- iii. The tilting of trees along the slide region has been observed suggesting slow downward motion. [Figure 6 (e)]
- iv. The pedestrian pathway has been damaged and large ground cracks have been observed. The road has been settling since the incidence of the landslide. The road has approximately subsided over 2m after the landslide incidence. Several ground cracks have been observed in the area.
- v. No *in-situ* rock cover at the foundation level of the civil structures has been observed.
- vi. A number of houses have developed cracks and the foundation of the civil structures have been damaged [Figure 6(f)].

RECOMMENDATIONS:

- i. The retrofitting of the affected building can be considered in due consultation with the design engineers.
- ii. Clearing out of the collapse building material from the slope.
- iii. Green colour Building located adjacent to incidence zone should be demolished. Cracks on the houses developed along the crown portion should be sealed by consulting geotechnical engineers.
- iv. Catch water drains or chute drains may be provided above the crown of the landslide to divert or channelize the water away from the slided area. Proper Drainage management system should be implemented around the settlements.
- v. Geojute/Geotextile may be used to protect the overburden face from further weathering and erosion on the slope affected by the incidence.
- vi. People should be educated about the ill-effects of unscientific slope modifications to avoid slope failures in future.
- vii. Tilt meters to be installed in one or more locations of the retaining wall/building falling within zone of influence. It measures any change in slope inclination near cracks and

areas of maximum anticipated rotational movement.

A slide was also observed at the Judge House, Mandi, Himachal Pradesh. The slide was caused by shallow rotational failure of the debris on super saturation of the overburden material owing to unprecedented rainfall during the preceding days. Construction of suitable retaining structures to provide support to the foundation is suggested in consultation with the design engineers. The tension cracks observed needs to be filled up with impervious materials like clay so that further seepage of the water may be avoided.

The debris part should be treated with geo textiling methods to contain further sliding of the area. The cracks and the slide as observed at the house of Judge, Mandi are shown in Figure 6 (g) and 6(h) respectively.



Figure 6 (f) Debris Slide at Judge House, Mandi with tension cracks covered by plastic sheets to avoid further percolation of water



Figure 6 (g) Cracks on floor of house repaired by filling by cement/ other cementing materials

An inventory of landslides at Tarna Hill, Mandi listing landslide investigations as first information is given with this report as Annexure-I.

Visit to the IPH building was also made. During the visit, it was found that the abandoned structure building was constructed over the unconsolidated debris material comprising silty sand matrix. No hard rock / in-situ rock was observed in the nearby area. There were many cracks observed on the wall as well as beam of the abandoned building. The major and wide were found

on the ground (Fig. 6 (h) and (i)) and subsidence was also observed in the form of displacement between the beam and the wall of the building as shown in Fig. 6 (k). The ground cracks were also observed in the pathway reaching the IPH building as shown in Fig. 6 (j)

CONCLUSION AND RECOMMENDATIONS

- i. The overall area is covered with very thick debris/overburden comprising mostly silty clay with organic soil. It should be ensured that foundation in the soft ground does not undergo shear failure during or under the loading the structure especially in the saturated wet conditions.
- ii. Future constructions will necessitate lightweight structures, and their foundations will be enhanced with the expertise of a structural engineer if applicable.
- iii. The type of joints which were seen on the building, whether they are contraction joints, construction joints or sliding joints are to be filled with strip of compressible material and to be sealed by suitable material as per the IS Code.
- iv. Providing insulating surfaces on top of the slab to reduce and delay penetration of heat into the structure; such insulated slabs shall be provided with expansion joints, at suitable intervals.
- v. The Tell-tales crack monitoring gauge is also suggested to be installed between the cracks to observe the vertical and horizontal movement across a crack.
- vi. It is suggested to prevent any infiltration of surface water or rainwater into the building, as it could deteriorate the foundation's condition.
- vii. The office of GSI, SU: P, H & HP, Chandigarh may please be contacted further during the construction activities, in case of any slope stability problem, if required



Figure 6 (h) showing wide ground cracks observed in the IPH building

Figure 6 (i) showing wide cracks on the walls of the IPH building



2. JUCCAIN SLIDE, SAKRAGHAT TEHSIL, MANDI

The area is located nearly 59 km from Mandi district and is approachable by all-weather metal road via Sanardh Road and Tarna Road. The falls in Survey of India Toposheet no 53A/10 at latitude 31.66694 N and 76.74722 E longitude. The area lies at an elevation of 930 m above MSL.

A catastrophic slide occurred on early morning hours of 14th August 2023, where debris material charged with large boulders brought down by a flash flood washing away a major portion of the Gor road, several houses and cow sheds, a village school and vehicles on the downslope. The debris material brought down by flash floods from the upslope area was triggered by head ward landslide due to incessant heavy rainfall during previous nights of 12th and 13th August, 2023. The incidence at the Juccain village can precisely be describe as a debris flow hit. The runout distance extends around 400 metres with a maximum spread of approximately 100 metres. The general slope of the flash flood debris flow in the down slope varies from 30° to 40° to steep > 45° in the upslope part. The google imagery showing the spread of the debris flow is shown in figure 7 (a).



Figure 7 (a) The google imagery showing the spread of the Juccain debris flow, Mandi District, Himachal Pradesh.

The flash flood area owing to its location in proximity to major tectonic plates like Main Boundary Thrust and Vaikrita Thrust approx. 3.5km west, exhibits highly jointed nature of bedrock. The rocks exhibited three set of joints. Figure 7 (c) exhibits the outcrop.

The details of the joints are as below in Table 2.

Table 2: Details of the joints of Juccain Village, Sarkaghat, Mandi

Joint	Strike	Dip Amount and Direction	Persistence (m)	Apperture (cm)	Hydrological Condition
J ₁	N20 ⁰	80 ⁰ → 110 ⁰	<1	0.1	Damp
J ₂	N260 ⁰	38 ⁰ → 170 ⁰	<1	0.3	Damp
J ₂	N140 ⁰	85 ⁰ → 230 ⁰	<1	0.2	Damp

The surrounding bedrocks, as a consequence, are highly fractured and deeply weathered attesting the easy supply of bouldery material for various kinds of valley fills. It was observed that the houses and the school were built alongside/on a first order stream, exacerbating the situation as well as the water flowed continuously. The water was in flowing condition. The figure 7(b) shows damage to school, Road, pathway and houses downslope.



Figure 7(b) I. showing damage to Gor Road and Govt. School, Juccain, Sarkaghat, Mandi



Figure 7(b) II. Damaged Govt. School, Juccain, Sarkaghat, Mandi premises





Figure 7(b) III. Damaged house on downslope of *nala* due to heavily charged boulders during flash floods.

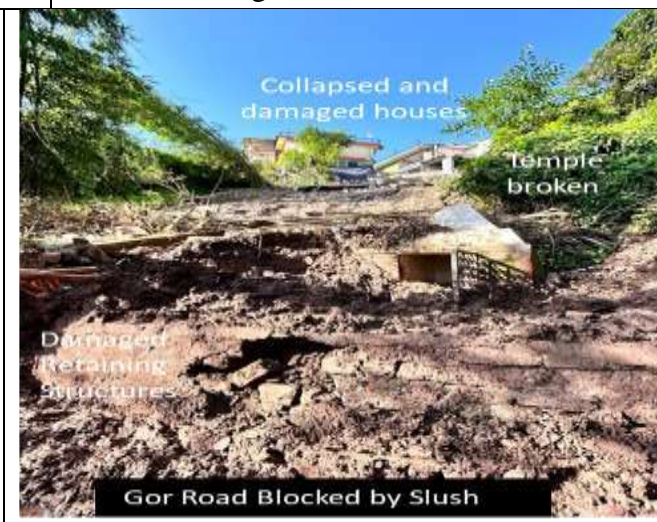
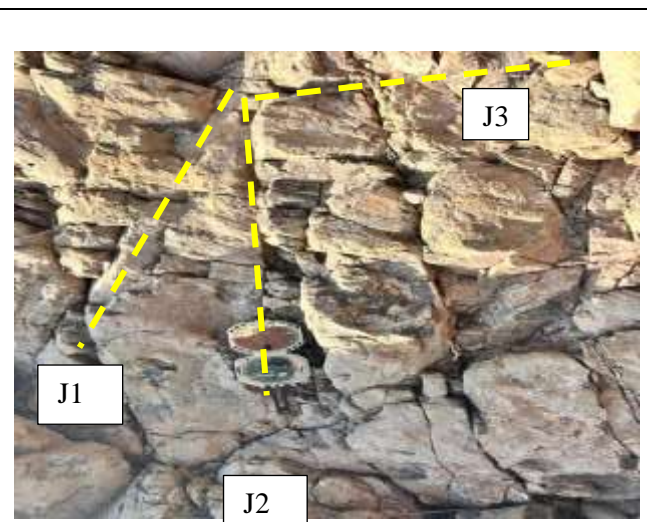

Figure 7(b) IV. Damaged Pathway connecting houses due to heavily charged boulders during flash floods.



<p>Figure 7 (c) Three set of joints exposed on sandstone outcrop</p>	<p>Figure 7 (d) The slide on the left bank of Juccain cloudburst site bringing down a house and damaging several others</p>
	
<p>Figure 7 (e). Cracks observed on the walls of effected buildings</p>	
	
<p>Figure 7 (f) Landslide on right bank of cloudburst site, damaging a house and completely burying 15 no. of goats</p>	

The adjoining landmasses on right and left banks have also been disturbed due the incidence of flash flood. It has been observed that the adjoining hill masses also suffered moderate landslides disrupting the communication at places.

A landslide on the left bank of site of cloud burst, approx. 65 m west, took away a major portion of hill mass and even though no casualties took place, the slide brought down a major building in the area and damaging several buildings in the proximity.

The slide also effected the road underneath and the retaining walls along with the drainage pipes/ channels and a small temple (Figure 7 (d)). Cracks have been observed on the walls of many buildings (Figure 7 (e)). The observations revealed the landslide to be a debris slide presently

triggered due to slope saturation. Landslide is a result of deep rotational mass failure occurred due to slope failure of unconsolidated slope material and saturation due to rainwater ingress and excessive erosion by the *nalas*. A retrogressive rotational failure is confirmed by presence of tension cracks at the crown of the slide as confirmed by the locals.

The landslide is 30m in length, 20m in width and nearly 20m in height. The landslide is active and single. Area exhibits generally moderate to steep slope of around 50°. Another landslide triggered due to the heavy rainfall on 14th, August, 2023 on the left bank of the cloud burst incidence. The slide even though on a much smaller scale caused widespread destruction. The slide was 15 m in length and 10 m wide, caused injury to two persons, death of 15 goats and a 1 buffalo, damage to a building and cow shed. The slide is debris slide and retrogressive in nature. The landslide is active, single with its toe terminating in mid hill part at the Gor road. The area exhibits generally moderate slope. The figure 7 (f) shows the landslide effected area.

The debris slides in Jucaain area is attributed to weakened slope debris due to water ingress and subsequent slope saturation by heavy rain. The absence of proper drainage network has played a crucial role in inducing the slope failure.

It has been observed that increased anthropogenic activities, such as ill planned construction of buildings, civil structures, and other infrastructure projects, have contributed to hill slope cutting and modification in recent years. This raises concerns about potential slope instability incidents or failures in the future, particularly if these activities are taken up without thorough geoscientific studies. The landslide area mostly comprises of sandstone, clay and purple shale of Dagshai Formation.

The Future Menace:

The observations along the *nala* revealed presence construction along first order stream which yielded of lot of bed load material comprising of precariously disposed large boulders. In view of the steep gradient of the upstream *nala*/gully, unstable side slope material and landslide prone upstream most part of the *nala*, the recurrence of debris flow/ flash flood incidence cannot be ruled out. In this effect and in view of rainy season still remaining ahead, it is suggested that the dwellers in the immediate downslope area on the left bank may be shifted to a safer place for the time being.

The buildings built on tension cracks may be stabilized with proper treatments. The area due to its close proximity to the major tectonic plane, the slides in future cannot be ruled out. Future constructions in the area may be constructed following BIS building codes.

Remedial Measures:

ALONG THE AREA OF FLASH FLOOD DEBRIS HIT AREA:

- i. Rehabilitation for time being of affected inhabitants of Juccain Village on the left bank of the downslope of the cloud burst area to a safer place in view of destabilized ground conditions and possible recurrence of incidence at the village.
- ii. Provision of barriers along the upstream *nala* on various levels.
- iii. The reclamation of the land mass after proper applications of ground stabilization measures like compaction, channelizing out the seepage, provisions of drainage outlet, provisions to check ground settling and retaining structure to confine the ground mass, protection wall from *nala* side etc.
- iv. Concrete retaining structure all along the road stretch terrace/debris cone material with adequate drainage holes.
- v. Settlement/construction for dwelling may be avoided along *nala*/khad/river banks or flood plain area and along the *nala* banks and dormant courses.
- vi. Suitable plantation/afforestation for the stabilization of *nala* banks.

ALONG THE DEBRIS SLIDE AREA:

- i. Immediate filling of transverse and contour parallel tension cracks with appropriate impervious material immediately.
- ii. Proper channelization for water to avoid its further ingress at the earliest away from the sliding zone.
- iii. No further construction, loading, tampering of slope with heavy civil structures in/adjoining failure affected zone.
- iv. Appropriately designed guide walls along *nala* courses, to prevent erosion and damage to civil structures (houses, road, culvert etc. below the lower level of road).
- v. Appropriately designed retention structures at suitably identified locations at lower levels as support to failing mass.
- vi. Biotechnical stabilization/ Plantation of suitably identified species that can hold the soil in the failure affected zone.
- vii. Vigil should be maintained by concerned authorities and local residents reg. slope instability phenomena/ development of slope instability signatures (e.g. bulging, cracks, land slips etc.) and timely intimation to concerned.
- viii. A landslide/ slope instability programme for local authorities/residents/students would be helpful.

An inventory of landslide at Juccain, Mandi listing landslide investigations as first information is given with this report as Annexure-II.

3. TATIHLANDSLIDE, SARKAGHAT, MANDI

The Tatihl landslide is a debris slide (Geographical coordinates: Latitude: 31.704166 N and 76.723511 E) located 0.5 km away from Sarkaghat Village, district Mandi, Himachal Pradesh. The study area falls in the Survey of India Toposheet No. 53A/13 and lies at an elevation of 960m MSL.

The landslide took away a major portion of hill mass without any known casualty. However, loss of property (connecting village roads, electric network, residential civil structures, cow sheds, car parking and vehicles) and fertile land have been reported. Several houses have developed cracks in the walls as shown in figure 8 (b). The transverse cracks in the adjoining parts of the slide can be indicate that the slide is retrogressive in nature with deep rotational failure of slope debris.

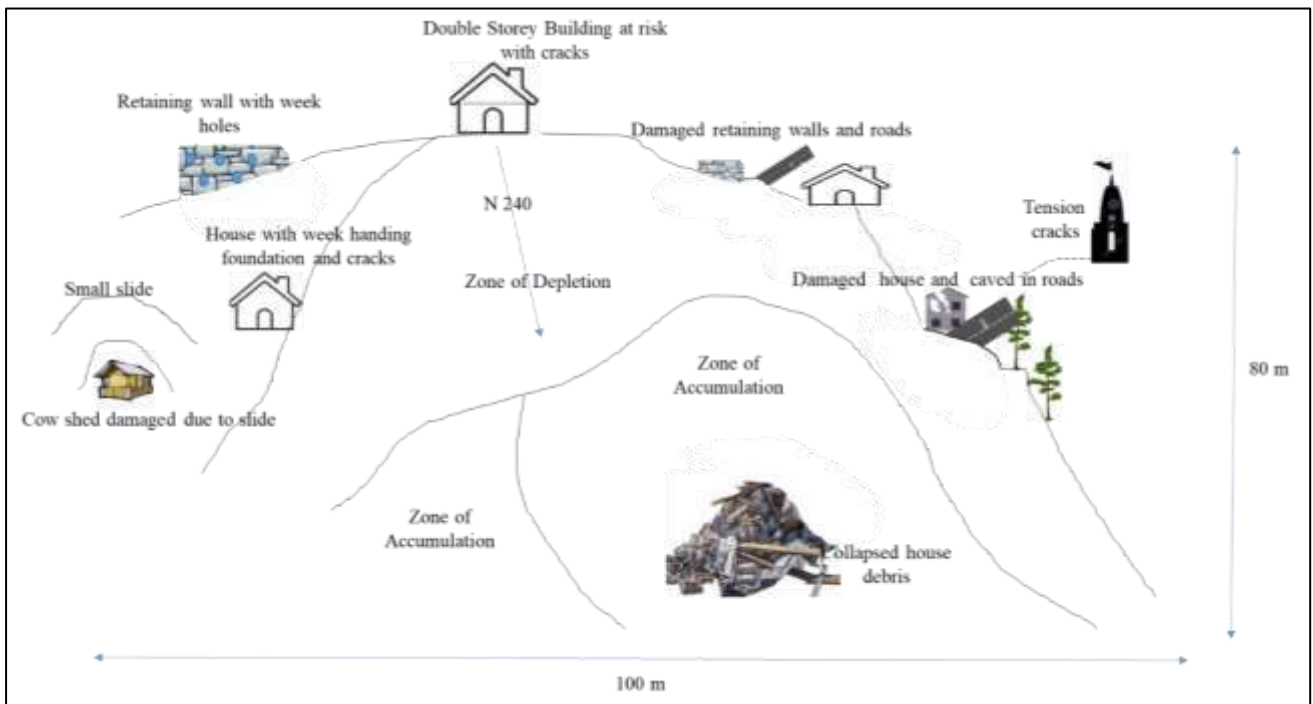

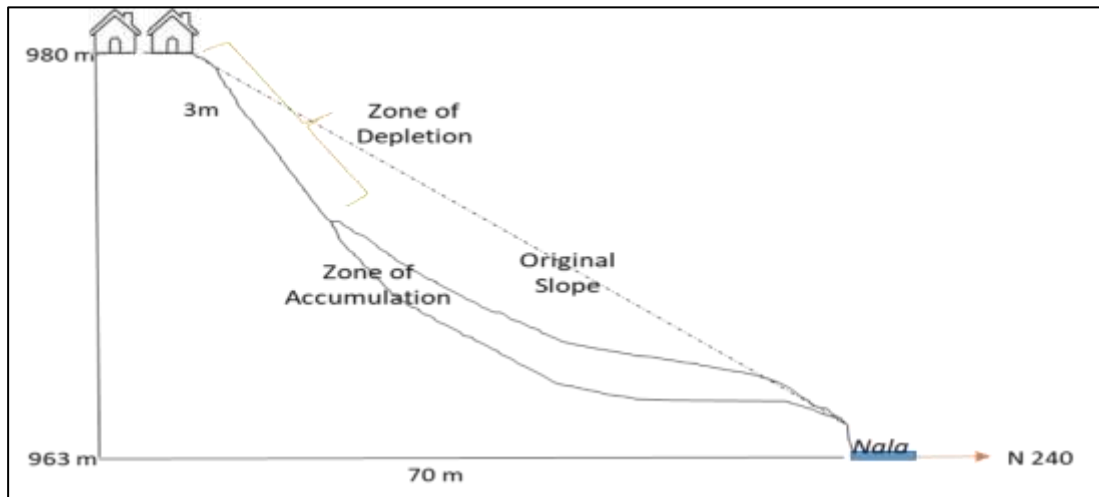

Figure 8 i) Schematic Diagram and ii) profile section of the Tatih Landslide, Mandi District, Himachal Pradesh.

The dimension of the slide is 80m in length, 40m in width and nearly 70m in height with steep slope. Figure 8 (a) demarcate the morphometry of the debris slide. Fig 8 (i) shows the schematic diagram of the slide and 8 (ii) shows the profile section of the slide.





The landslide exhibits a retrogressive nature with its toe terminating approximately 80 m downslope in a *nala*. The underlying bed rock primarily comprises of sandstone and siltstone belonging to Dagshai Formation of Sirmur Group. The study revealed the landslide to be a debris slide triggered by slope saturation due to infiltration of rain water on the crown portion. This infiltration led to differential stress at the hill top inducing slope instability. Absence of adequate drainage network, coupled with prolonged and intense rainfall in the area in past few days have drastically worsened the situation deteriorating the slope stability and ultimately causing the slope failure.

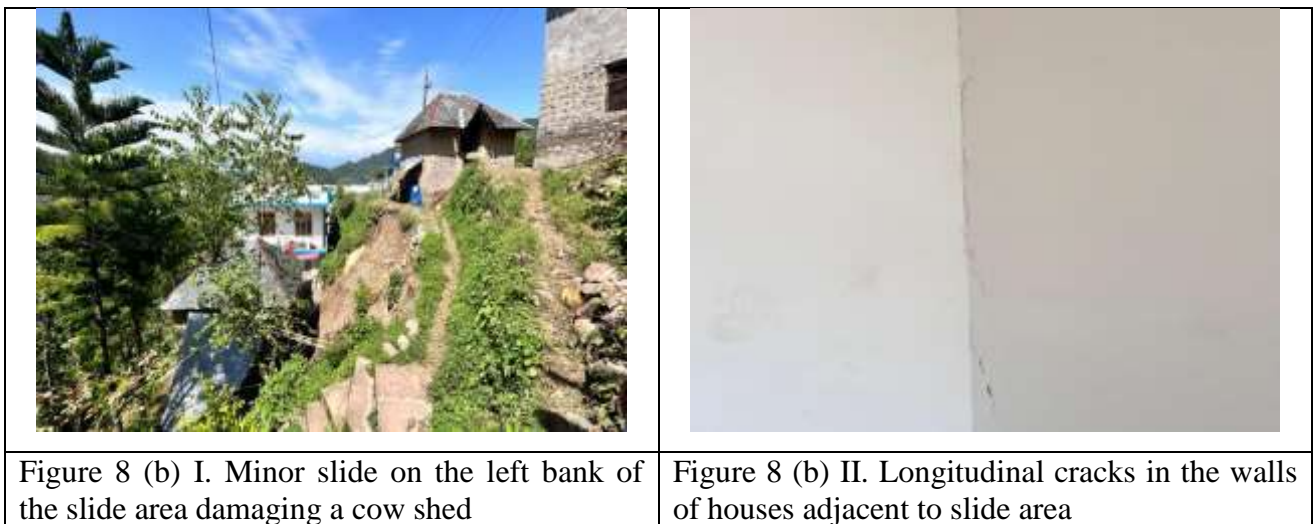

The present and future menace:

The landslide is expected to remain unstable if uphill masses are not dealt carefully and scientifically. Also, prima facie, the village establishment in further uphill area, appears to be on stable ground/slope, however, the uphill mass including the village establishments must to put to frequent

observations for any ground signatures of slope instability such as development of tension cracks, land sinking, tilting of tree, sudden appearance or disappearance of any *nala* etc. The downstream shoulder of landslide appears a slumped mass. The new road alignment must avoid this distress rock mass stretch.

Remedial Measures

- i. Proper channelization for water to avoid its further ingress at the earliest away from the sliding zone.
- ii. The benching in uphill debris mass as well as in rock mass, may be carried out very carefully, scientifically along with their simultaneous effective stabilization.
- iii. The up-slope hill mass and village establishments must be put to frequent observations with regards to any ground signature of instability such as developments of tension crack, joint openings/ widening, land sinking, development of crack in building, collapse of soil along slope or *nala*, tilting of trees, sudden appearance or disappearance of surface stream or reduction in water volume etc.
- iv. Immediate filling of transverse and contour parallel tension cracks with appropriate impervious material immediately.
- v. Altering the geometry of the steep slope by flattening and benching along with draining out any ingressing *nala* or rain water.
- vi. Use of soil nailing, grouting, wire mesh draping, biotechnical slope stabilization measures (plantation of suitable trees with deep rooted species, application of geo-jute/geo-mats etc) in the slope debris mass of the uphill and downhill (road/ dump filling).
- vii. The suitable retaining structures must be provided with adequate filter and drainage, in particular, when constructed in debris filled mass.
- viii. The retrofitting of the affected building can be considered in due consultation with the design engineers
- ix. People should be educated about the ill-effects of unscientific slope modifications to avoid slope failures in the future.

An inventory of landslide at Tathi, Sarkaghat, Mandi listing landslide investigations as first information is given with this report as Annexure-III.

4. NARERA CLOUDBURST SLIDE, MANDAP TESHIL, MANDI

The area is located nearly 55 km from Mandi district and is approachable by all-weather metal road via Una - Jahu - Ner Chowk Road. The Narera area located at EL 900 m MSL. The slide area falls in Toposheet no. 53 A/13. The geographical co-ordinates of the slide area lies at 31.793055 N and

76.780555 E.

The area is marked by presence of several boulder colluviums, slope debris and debris cone as the main geomorphic constituent present in the foothill zone hosting nearly all the village establishments. The village is also located at the foothill debris cone of a major hill spur. The hill mass is moderately dissected and forested. The perspective view of the slide is given in figure 9 (a).



Figure 9 (a) Prospective view of the Cloud burst triggered debris slide, Narera Village, Dharampur, Mandi District, Himachal Pradesh.

Geologically, the slide area located itself within the sandstone and purple shale of Dakshai Formation, Sirmur Group and exposes the major tectonic feature of Vaikrita Thrust in downslope proximity. The surrounding bedrocks, as a consequence, are highly fractured and deeply weathered attesting the easy supply of bouldery material for various kinds of valley fills. Figure 9 (c) shows the boulder material brought by the flash flood triggered debris slide.

The catastrophic slide occurred at 06.30 hrs (approx.) on 14.09.2023 at Narera village resulting in loss of live-stock and washing away of several major houses and cow sheds, 90 m stretch of NH-03, village roads and 50 bigah of agricultural lands. The damaged houses, village roads and NH-03 are shown in Figure 9 (b).

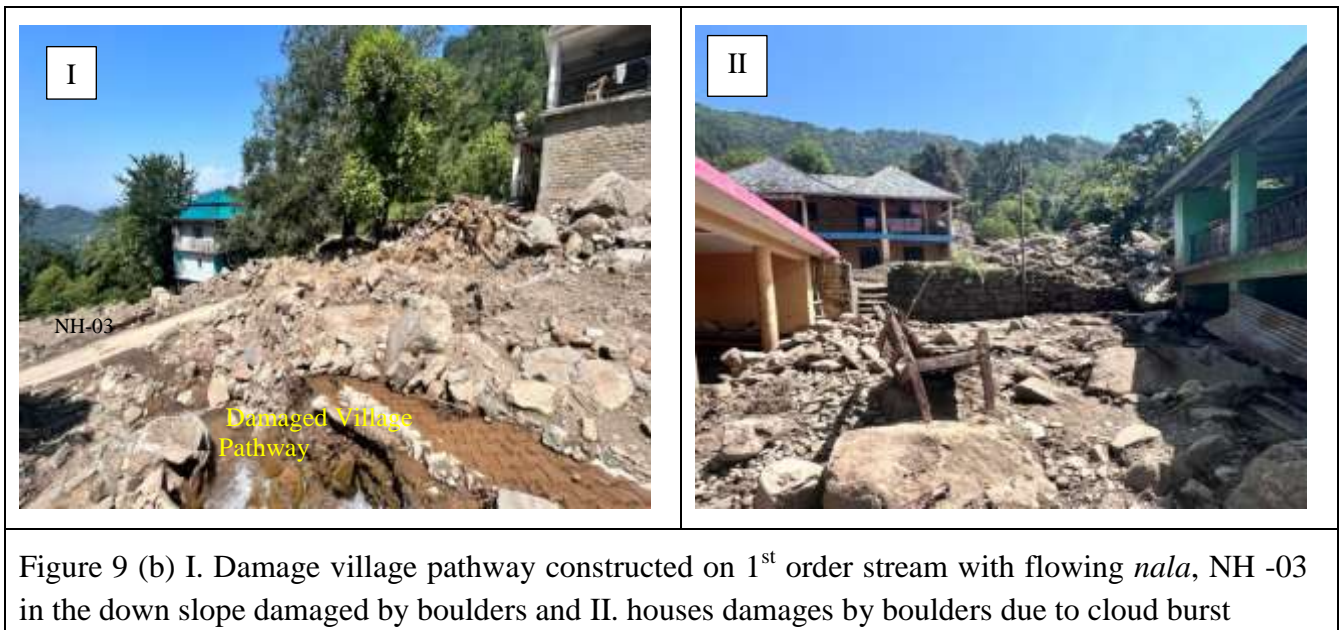

Figure 9 (b) I. Damage village pathway constructed on 1st order stream with flowing *nala*, NH -03 in the down slope damaged by boulders and II. houses damages by boulders due to cloud burst

A similar incidence of flash flood on a smaller scale had occurred in 2014. The recent incidence also made the adjoining areas unstable effecting the 25 families living in the village. The damage was caused by a flash flood charged with debris flow in the upslope incised gully triggered by head ward landslide due to incessant heavy rainfall during previous nights of 12th and 13th August, 2023. Therefore, the incidence at the Narera village can precisely be describe as a debris flow hit. The *nala* course split into three sublets at the downstream end, possibly facilitated the spread of debris flow over the entire village establishment. The *nala* splitting into three units can be seen in figure 9 (a). As on date of visit, the entire village landmass is destabilized and can be reclaimed only after proper ground stabilization applications.



Figure 9c. Boulders consisting of sandstone, siltstone, volcanics and quartzites on the village pathway brought down by the flash floods.

The Future Menace:

The observations along the *nala* revealed presence of lot of bed load material comprising of precariously disposed large boulders. In view of the steep gradient of the upstream *nala*/gully, unstable side slope material and landslide prone upstream most part of the *nala*, the recurrence of debris flow/ flash flood incidence cannot be ruled out. In this effect and in view of rainy season still remaining ahead, it is suggested that the dwellers in and surrounding area may be shifted to a safer place. The above pursuit of safety may also be followed in other villages/ habitats, in particular for those living along *nala* banks and dormant *nala* courses.

Remedial Measures:

- i. Rehabilitation of affected inhabitants of Narera and adjoining area to a safer place in view of destabilize ground condition and possible recurrence of incidence at the village.
- ii. The reclamation of the land mass after proper applications of ground stabilization measures like compaction, channelizing out the seepage, provisions of drainage outlet, provisions to check ground settling and retaining structure to confine the ground mass, protection wall from *nala* side etc.
- iii. Prohibition of flow barriers all along upstream *nala* course at suitable distances
- iv. Provision of concrete lined spacious *nala* course with a provision of culvert on the road ensuring the easy passage of debris flow.

- v. Concrete retaining structure all along the road stretch terrace/debris cone material with adequate drainage holes
- vi. Launch of landslide safety (vulnerability identification) programs in villages/habitat located in such fragile Geo-environmental area
- vii. Conducting regular contact programs for public awareness of landslide and related incidences in particular during pre-monsoon.
- viii. Settlement/construction for dwelling may be avoided along *nala/khad*/river banks or flood plain area and along the *nala* banks and dormant courses.
- ix. Suitable plantation/afforestation for the stabilization of *nala* banks and disturbed ground
- x. Implementation of safe and scientific methods of slope modification and stabilization.
- xi. Identification of stable ground for safe construction and urbanization with proper drainage outlets and protection wall.
- xii. Widespread advance communication/warning to the dwellers regarding heavy rainfall.

An inventory of landslide at Narera, Mandi listing landslide investigations as first information is given with this report as Annexure-IV.

5. LANDSLIDE/ LAND SUBSIDENCE ALONG RIYUR AND ADJOINING VILLAGES:

Riyur village falls in survey of India Toposheet no.53 A/13 and can be reached by the all weathered road via Mandi - Dharmpur National Highway, NH-03.

During the months of July, August and September 2023 following heavy spells of rainfall, a large number of reactivated and fresh landslides with subsidence developed at several places all along the Riyur area of Mandap, Dharmampur, Mandi causing damage to human settlements, communication network, cultivated land and forests. Creeping and tilting of trees at many locations were observed (Fig. 10 s) during the preliminary studies.

Geologically, the area is occupied by the rocks of Palaeo-Meso-Proterozoic succession represented by the Kulu, Vaikrita, Sundernagar and Shali Groups, Palaeogene and Neogene are constituted of Sirmur and Siwalik Groups of rocks respectively. Undifferentiated Quaternary deposits of late Pleistocene to Holocene age along with Palaeozoic Mandi Granitoid are also exposed in the area

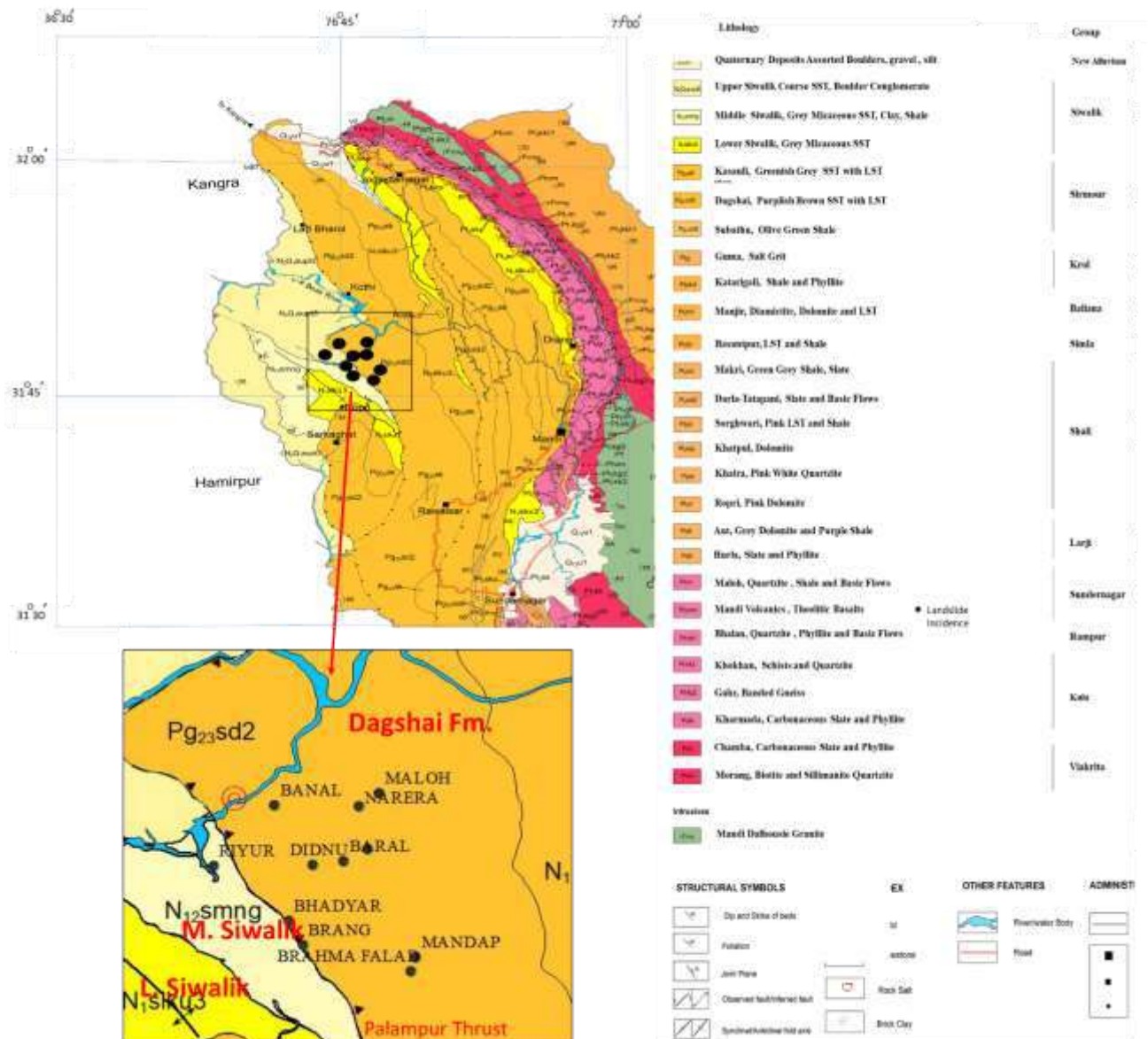

Figure 10: Geological Map of landslide effected areas near Riyur and adjoining villages, Dharampur, Mandi

Geomorphologically, the area, forms a part of Lesser Himalaya characterized by rugged and mountainous topography that in turn is controlled by the lithology and structure. The location coordinates of landslide incidences have been given in Figure 10.

The landslide affected area is occupied by the sandstone and shale of Dakshai Formation, Sirmur Group. The elevation of the area varies from 700 -900 m MSL.



Figure 10 (a) Prospective view of Banal landslide, Dharampur, Mandi



Figure 10 (b) Prospective view of Mandap landslide, Dharampur, Mandi



Figure 10 (c) 1) Prospective view of Maloh landslide, Dharampur, Mandi
2) Debris slide at Maloh landslide, Dharampur, Mandi and development of ground cracks >1m



Figure 10 (d) Cracks observed on walls and floors of buildings and displacement of stairway due to landslide near Riyur and Collapsed building near Riyur village, Mandi district, HP



Figure 10 (e) Landslide at Badiyar village, Dharampur, Mandi charged with heavy boulders



Figure 10 (f) Prospective view of Didnu landslide, Mandi



Figure 10 (g) Damage to house due to boulders from landslide at Brahmfalad, Dharampur, Mandi



Figure 10 (h) Ground cracks on roads of Badhiyar village, Dharampur, Mandi



Figure 10 (i) Caving of road due to landslide at Banal village



Figure 10 (j) Caving of road due to landslide at Banal village



Figure 10 (k) Ground cracks observed on road due to landslide at Mandap village, Mandi



Figure 10 (l) Major slide observed in Banal Village, Mandi effecting the road and putting houses at risk



Figure 10 (m) Subsidence observed near road at Brahmfalad village



Figure 10 (n) Observance of ground craks on raod near Chanauta Village



Figure 10 (o) Subsidence of land >5m near Banal village, Mandi district. HP



Figure 10 (p) Ground cracks and subsidence of land observed around Riyur and adjoining villages



Figure 10 (q) Subsidence of land >1m on road near Brahamfalad village, Mandi



Figure 10 (r) Broken retaining structure due to silde near Riyur village



Figure 10 (s) Creeping and titling of trees showing continuous downward movement at Barang Village



Figure 10 (t) Debris slide observed at Baral village, Mandi district, HP



Figure 10 (u) Caving of road and development of tension cracks om roads near Barouti village



Figure 10 (v) Land Subsidence and tension cracks observed near Badhiyar village



Figure 10 (w) Collapsed house at Barouti Village, Mandi district, HP



Figure 10 (x) Damaged retaining wall and electric pole at the ITI Building Landslide near Riyur village.



Figure 10 (y) Damaged houses due to slide at Didnu Village



Figure 10 (z) Cracks observed on walls and floors of buildings and displacement of beam of buildings

Investigation and mitigations/ remedial measures

The study and assessment of affected sites reveals that steep slopes, high relief, thick slope wash material/overburden and glacio-fluvial deposits, complex structural fabrics and proximity to Main Central Thrust (MCT), and Vaikrita Thrust have rendered the slopes highly vulnerable to mass movements. Further, anthropogenic activities like widening and construction of new road and varied unfavourable geological (highly weathered and jointed rocks), hydrogeological condition, slope erosion have created conditions for numerous rock and debris slides/falls. The most important causative factor for the triggering and development of landslide is the continuous heavy rainfall. It

has led to the saturation of thick slope wash debris material/highly weathered rock.

A total of 9 landslide effected villages covering an area of 21 Km² have been examined. GSI, Chandigarh would take up a meso-scale landslide susceptibility mapping project in the Riyur and its adjoining villages on priority during FS 2024-25.

The list of areas examined area as below:

- 1) Riyur (Figure 10 d)
- 2) Mandap (Figure 10 b)
- 3) Chanouta (Figure 10 n)
- 4) Barang (Figure 10 l)
- 5) Badiyar (Figure 10 e)
- 6) Banal (Figure 10 a)
- 7) Maloh (Figure 10 c)
- 8) Didnu (Figure 10 f)
- 9) Brahmafalad (Figure 10 q)
- 10) Barouti (Figure 10 w)

The Badiyar and Baral villages are the worst effected by serious of disastrous slides disrupting the communication all together. Subsidence in form of ground cracks figure 10 p), displacement of beam of houses (Fig 10 z) , caving of roads (Fig 10 I & J) etc were observed in a number of places. Large number of houses with major cracks were also recorded (Fig 10 w and y).

Generalized suggestions and recommendations have been given for mitigation of this problem so that the recurrence of damages caused by similar incidences in future can be minimised. Attention is required to arrest the recurrence of major landslides. Suitable mitigation measures / remedial measures have been suggested including provision of drainage by providing contour and longitudinal drains, plantation, channeling of perennial streams, construction of check-walls and retaining-cum-breast wall, river training works etc. The slopes of these slides can also be moderated by benching of failed slopes at less than 15°.

An inventory of Riyur landslide investigations as first information is given with this report as Annexure-V.

6. PHAGWAON, DHANOTU, SUNDERNAGAR, MANDI

The study and assessment of affected sites around Phagwaon and Phagwas village were carried out in

response to the request by Deputy Commissioner Letter No DC/MAN/DDMA/DEOC/ 3526-27 dated 19th August 2023 regarding sinking of Phagwaon village after a significant rift developed along Nalani-Phagwaon road. The area is located approximately 50 km from Mandi district and is approachable by all-weather metal road via Sundernagar- Mandi Highway (SH-13). Physiographically, the area falls within the Lesser Himalaya. Geologically, the area is occupied by rocks of Khokan Formation, Kulu Group.

The Palaeo-Proterozoic Kulu Group is characterised by chlorite schist and quartzite.

The study revealed that steep slopes, high relief, and thick slope wash material/overburden complex structural fabrics and proximity to Vaikrita Thrust (Phagwaon village) and Kullu Thrust (Phagwas village) rendered the slopes highly vulnerable to mass movements. The surrounding bedrocks, as a consequence, are highly fractured and deeply weathered attesting the easy supply of boulder material for various kinds of valley fills. The Phagwaon village is situated in between two major hill spurs. The hill mass is moderately dissected and forested with scattered settlements.

The study and assessment of affected sites around revealed varied unfavourable geological (highly weathered rocks due to its proximity to two thrust zones) and hydrogeological conditions. The most significant causative factor for the triggering and development of landslide is the continuous heavy rainfall leading to saturation of thick slope wash debris material/highly weathered rock and poor drainage system.

No crown could be located on the day of field studies but several ground cracks along settlements and road corridor was observed. According to the Pradhan of Phagwaon village, the ground cracks developed on 14.08.2023 along three buildings and road corridors as shown in figure 11. This lead to the evacuation of the buildings, and since then and the ground cracks have been widening ($\pm 30-50\text{cm}$) affecting about $\pm 2.5\text{m}$ road stretched. Fortunately, no casualties were recorded. The 42 point parameters of Phagwaon and Phagwas (Doldhar) Village is given in annexure VI.

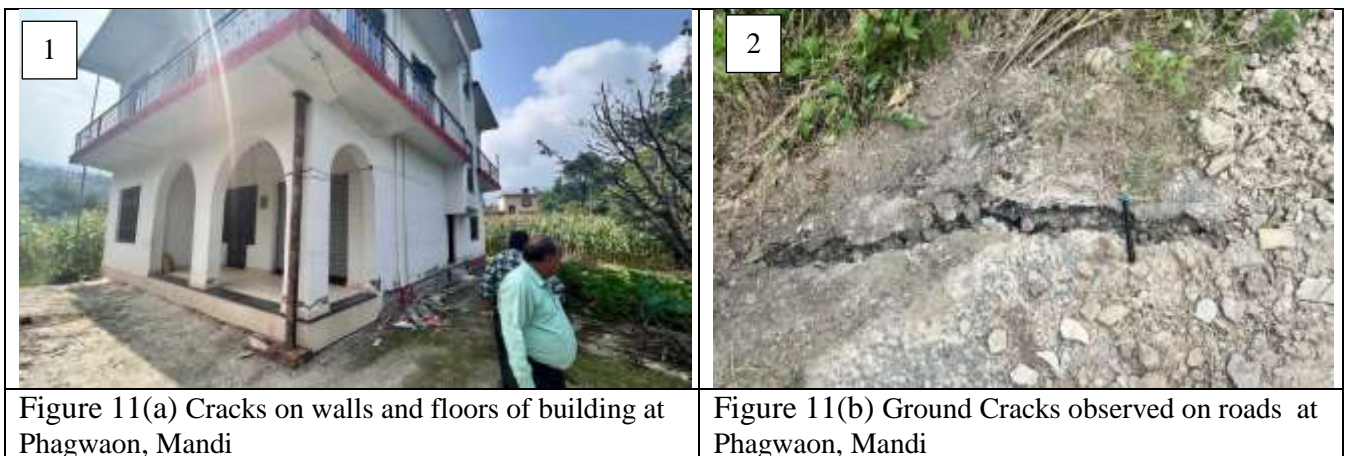



The Future Menace:

The observations along Phagwaon village reveal the presence of highly weathered *in-situ* rock mass and a significant amount of precariously disposed schist boulders in the debris. Considering the village's close proximity to Vaikrita and Kulu thrusts, any seismic activity or intense rainfall could potentially trigger a landslide. In this effect and in view of rainy season in the coming years, it is highly recommended to design an effective drainage system. This will aid in mitigating the risk associated with slope instability and prioritize the safety of the village residents. This safety-oriented approach should also be extended to other villages/ habitats, especially to those in proximity to thrust zones, to ensure comprehensive hazard mitigation and community well-being.

Remedial Measures:

- i. Removal of loose and precarious boulders along the road bench to enhance safety.
- ii. Provision of sturdy retaining structures with staggered drains and weep holes at the hillside road level to prevent soil erosion.
- iii. Sealing of ground cracks with impervious material to minimize water infiltration and further damage.
- iv. Retrofit and reinforce existing structures in the village, including roads and buildings to improve their resistance to seismic events or ground movements thereby enhancing their structural integrity.
- v. Installation of monitoring devices to constantly track ground movements, slope stability and soil moisture levels for timely intervention and hazard mitigation.
- vi. Implement early warning systems to promptly alert residents and authorities about potential landslide events, enabling swift evacuation and response efforts.

- vii. Improve drainage system to efficiently manage surface water runoff, mitigating the risk of slope destabilization. Design proper drainage channels to divert water away from vulnerable regions.
- viii. Establish and enforce stringent zoning regulations and land use plans that limit construction in high-risk areas. Ensure new construction adheres to building codes that account for geo-environmental hazards and incorporate appropriate setback distances.
- ix. Conduct community awareness programs to educate residents about the geological risks associated with living near a thrust zone. Promote disaster preparedness, conduct drills, and provide information on evacuation procedure.

An inventory of landslides listing Phagwaon Village investigations as first information is given with this report as Annexure-VI

---Sd---

(Wangshitula Ozukum)

Geologist

---Sd---

(Shreyasi Mahapatra)

Sr. Geologist

ANNEXURE I

**42 POINT GEOPARAMETRIC DATASHEET FOR TARNA HILL
DIST.MANDI, HP**

No	Field	Description
1	Slide No	HP/MAN/53A14/2023/
2	State	Himachal Pradesh
3	District	Mandi
4	Toposheet No	53A/14
5	Slide Name	Tarna Hill debris slide
6	NH/SH Location	Near Hotel Koyal, Mangwai Road
7	Latitude	31.705220 N
8	Longitude	76.933442 E
9	Length	±80 m (Max. as on date of field observation)
10	Width	±50 m (Max. as on date of field observation)
11	Height	±70 m (Max. as on date of field observation)
12	Area	±4000 m ² (Max. as on date of field observation)
13	Depth	>5m
14	Volume	±20000 m ³ (Max. as on date of field observation)
15	Run out distance	---
16	Type of Material	Debris
17	Type of movement	Slide
18	Rate of movement	Rapid
19	Activity	Active
20	Distribution	Enlarging
21	Style	Single
22	Failure mechanism	Deep rotational failure
23	History	Initiated on 14 th August 2023 (Morning)
24	Geomorphology	Lowly dissected hill
25	Geology	Basalt and quartz arenite, Mandi volcanics, Sundernagar Group.
26	Structure	S ₀ // J ₁ =30°/N170°, J ₂ =70°/N290°, J ₃ =85°/N340° The slide is situated in close proximity to Kullu thrust and Mandi-Sundernagar Thrust.
27	Land use/land cover	Settlement
28	Hydrological condition	Damp
29	Triggering factor	Rainfall
30	Death of persons	---
31	People affected	Settlement on the crown portion and right and left flank of the incidence zone.
32	Live-stock loss	---
33	Communication	Mangwai road affected, local pavement on the crown portion destroyed
34	Infrastructure	Electric pole on the crown portion at risk.
35	Agriculture/forest /barren	---

36	Geoscientific Causes	The most important causative factor for the triggering and development of landslide is the continuous heavy rainfall and oversaturation of water within the fragile and loose material of slope forming material leading to slope failure.
37	Remedial measures	<ul style="list-style-type: none"> i. Sealing of ground cracks wherever possible by impervious material (impervious clay, tar etc.) to restrict water infiltration. Area above the crown of landslide needs to be monitored for development of any new ground cracks. The cracks must be sealed either by filling them with clay or other impervious fill like Bentonite to reduce further permeability to ensure surface water does not pond in the area. ii. Several loose boulders present on the slope area between crown and Mangwai road corridor can be removed manually and modified slope in to terraces for multi levels using adequate retaining wall structure with a provision of weep holes. iii. Construction of proper lined drainage at the crown portion to arrest maximum infiltration of water surface water into distressed zone. iv. Ensuring construction of the Civil Structures strictly following building BIS codes. v. Site specific detail investigation should be carried out.
38	Remarks, if any	---
39	Photos. Sketch of Plan & section of the slide	 <p style="text-align: center;">Fig 1: Debris slide near Koyal Hotel.</p>

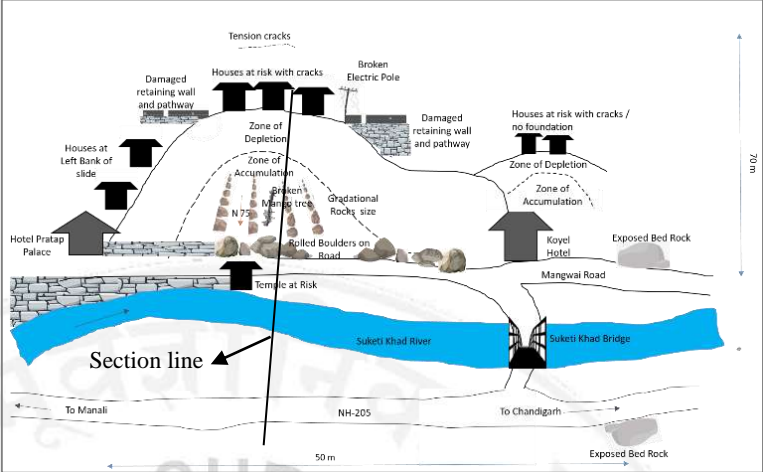
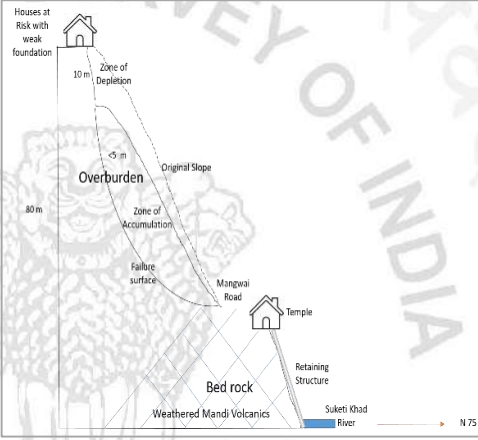
		 <p style="text-align: center;">Fig 2: Schematic Plan of the slide zone</p>  <p style="text-align: center;">Fig 3: Section along the central portion of the slide zone.</p>
40	Summary/Abstract	<p>Since the first week of August 2023, Tarna Hill has shown signs of structural deterioration due to continuous heavy rainfall in July 2023. The situation worsened following the relentless rains on 12th and 13th August, culminating in a slide on 14th August 2023. This event resulted in the collapse of one building and significant damage to several others, prompting residents to evacuate. Fortunately, prompt action by district authorities averted casualties. It is a debris slide triggered due to oversaturation of debris material due to heavy rainfall. This slide obliterated pathways, drainage systems and disrupted essential services like electricity. Various diagnostic signs revealed the slide’s enlarging nature, presenting an imminent threat to nearby structures. The crown portion exhibited tension cracks and the presence of natural springs. The areas geology and its proximity to thrusts and high grade of weathering indices contributed to its susceptibility to landslides. The assessment emphasizes the importance of proper construction practices and effective mitigation strategies to address the looming threat of landslides in the area.</p>
41	Pdf	Attached
42	Landslide alert category	Category I

No	Field	Description
1	Slide No	HP/MAN/53A14/2023/
2	State	Himachal Pradesh
3	District	Mandi
4	Toposheet No	53A/14
5	Slide Name	---
6	NH/SH Location	Near HPPWD Circuit house, Tarna Hill
7	Latitude	31.700833 N
8	Longitude	76.927222 E
9	Length	±80 m (Max. as on date of field observation)
10	Width	±80 m (Max. as on date of field observation)
11	Height	±70 m (Max. as on date of field observation)
12	Area	±6400 m ² (Max. as on date of field observation)
13	Depth	>5m
14	Volume	±38400 m ³ (Max. as on date of field observation)
15	Run out distance	---
16	Type of Material	Debris
17	Type of movement	Slide
18	Rate of movement	Rapid
19	Activity	Active
20	Distribution	Enlarging
21	Style	Single
22	Failure mechanism	Deep rotational failure
23	History	Initiated on 14 th August 2023 (Morning)
24	Geomorphology	Lowly dissected hill
25	Geology	Quartzite and shale, Maloh Formation, Sundernagar Group.
26	Structure	---
27	Land use/land cover	Settlement on the crown and Moderate vegetation
28	Hydrological condition	Damp
29	Triggering factor	Rainfall
30	Death of persons	---
31	People affected	Settlement on the crown portion and right and left flank of the incidence zone.
32	Live-stock loss	---
33	Communication	Local pavement along the crown portion destroyed
34	Infrastructure	Electric pole on the crown portion at risk. Cracks developed along 6 buildings located on the left flank of the incidence.
35	Agriculture/forest /barren	---
36	Geoscientific Causes	i. The most important causative factor for the triggering and development of landslide is the continuous heavy rainfall and oversaturation of water within the fragile and loose

		<p>material of slope forming material leading to slope failure.</p> <p>ii. Foundation failure</p>
37	Remedial measures	<p>i. Clearing out of the collapse building material from the slope.</p> <p>ii. Green colour Building located adjacent to incidence zone should be demolished. Cracks on the houses developed along the crown portion should be sealed by consulting geotechnical engineers.</p> <p>iii. Catch water drains or chute drains may be provided above the crown of the landslide to divert or channelize the water away from the slided area. Proper Drainage management system should be implemented around the settlements.</p> <p>iv. Geojute/Geotextile may be used to protect the overburden face from further weathering and erosion on the slope affected by the incidence.</p> <p>v. People should be educated about the ill-effects of unscientific slope modifications to avoid slope failures in future.</p> <p>vi. Tilt meters to be installed in one or more locations of the retaining wall/building falling within zone of influence. It measures any change in slope inclination near cracks and areas of maximum anticipated rotational movement.</p>
38	Remarks, if any	
39	Photos. Sketch of Plan & section of the slide	 <p>Fig: Prospective view of the collapse structure site.</p>

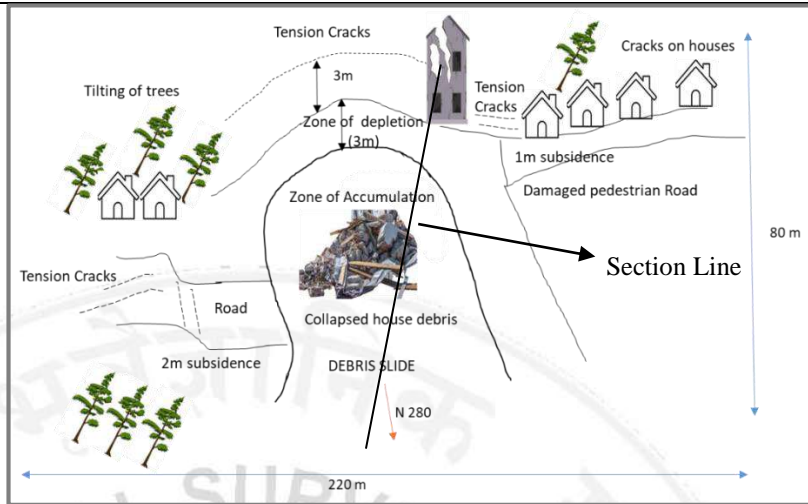

Fig 2: Schematic plan view of the affected area

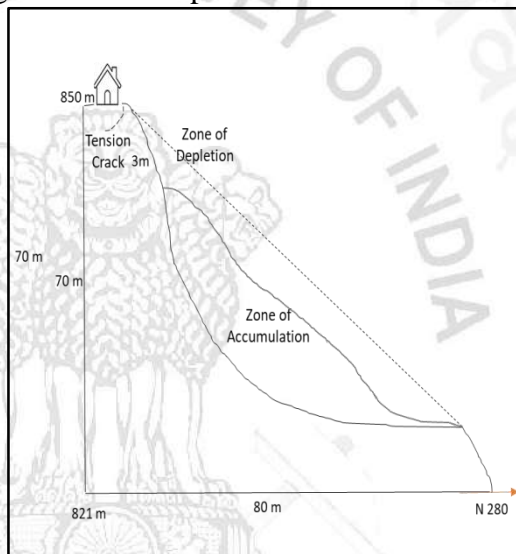

Fig 3: Section along the central portion of the affected zone.

40	Summary/Abstract	The debris slide near HPPWD Circuit house in Tarna Hill was reported on 14 th August 2023 which resulted in the complete collapse of a building and foundational damage to nearby structures. Tension cracks were identified above the slide area. This slide is progressively widening as indicated by the continuous subsidence of the pathway situated in the middle of the slide zone. The preliminary assessments underscore the urgency for effective mitigation measures and appropriate land use planning to mitigate landslide risks in the area.
41	Pdf	Attached
42	Landslide alert category	Category I

ANNEXURE-II

**42 POINT GEOPARAMETRIC DATASHEET FOR JUCCAIN CLOUDBURST,
DIST.MANDI, HP**

No	Field	Description
1	Slide No	HP/MAN/53A10/2023/
2	State	Himachal Pradesh
3	District	Mandi
4	Toposheet No	53A/10
5	Slide Name	Juccain Cloudburst
6	NH/SH Location	Juccain Village
7	Latitude	31.66694 N
8	Longitude	76.74722 E
9	Length	±400 m (Max. as on date of field observation)
10	Width	±100 m (Max. as on date of field observation)
11	Height	±380 m (Max. as on date of field observation)
12	Area	±40000 m ² (Max. as on date of field observation)
13	Depth	>5m
14	Volume	±200000 m ³ (Max. as on date of field observation)
15	Run out distance	---
16	Type of Material	Debris
17	Type of movement	Flow
18	Rate of movement	Extremely Rapid
19	Activity	Active
20	Distribution	Widening
21	Style	Single
22	Failure mechanism	Deep rotational failure
23	History	Initiated on 13 th August 2023 (06:00AM)
24	Geomorphology	Lowly dissected hillslope
25	Geology	Sandstone and purple shale, Dakshai Formation, Sirmur Group
26	Structure	S ₀ // J ₁ =80°/N110°, J ₂ =38°/N165°, J ₃ =85°/N230°
27	Land use/land cover	Settlement (Right and left flank) and Moderate to dense vegetation
28	Hydrological condition	Flowing
29	Triggering factor	Rainfall/ cloudburst
30	Death of persons	---
31	People affected	Locals residing along the right and left flank of the incidence zone.
32	Live-stock loss	
33	Communication	Local Bridge washed out
34	Infrastructure	1 house, 1 car and 1 bike damaged
35	Agriculture/forest/b arren	Agriculture
36	Geoscientific Causes	<ul style="list-style-type: none"> i. Saturation of water within the fragile and loose material of slope forming material during heavy precipitation. ii. The damage was caused by a flash flood charged with debris flow in the upslope incised gully triggered by head ward landslide due to incessant heavy rainfall during

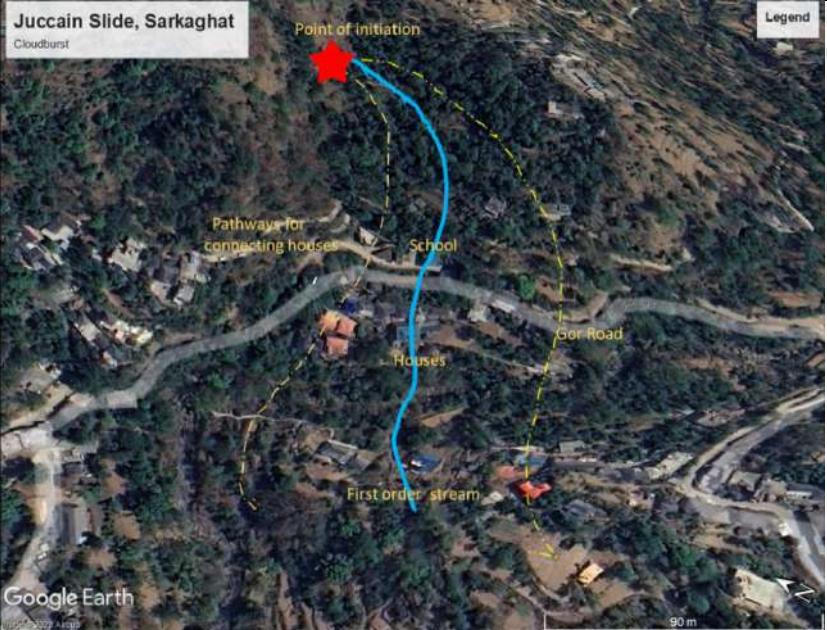
		previous days (i.e 12 & 13 th August 2023).
37	Remedial measures	<ol style="list-style-type: none"> i. The reclamation of the land mass at Juccain village after proper applications of ground stabilisation measures like compaction, channelizing out the seepage, provisions of drainage outlet, provisions to check ground settling and retaining structure to confine the ground mass, protection wall from <i>nala</i> side etc. ii. Provision of flow barriers all along upstream <i>nala</i> course at suitable distances iii. Provision of concrete lined spacious <i>nala</i> course with a provision of culvert on the road ensuring the easy passage of debris flow. iv. Concrete retaining structure all along the road stretch terrace/debris cone material with adequate drainage holes. v. Suitable plantation/afforestation for the stabilization of <i>nala</i> banks and disturbed ground vi. To the degree possible, straighten and channelize flow paths through the settlement, stacking sandbag walls parallel to the direction of flow as a temporary measures and building Earthen and concrete deflection and terminal berms where necessary to better confine the flow as a permanent measures.
38	Remarks, if any	---
39	Photos. Sketch of Plan & section of the slide	 <p>The image is a satellite view from Google Earth showing a landslide area. A red star marks the 'Point of initiation' at the top. A blue line traces the path of the debris flow down the slope. Yellow dashed lines indicate 'Pathways for connecting houses'. Other labeled features include 'School', 'Houses', 'Gor Road', and 'First order stream'. The text 'Juccain Slide, Sarkaghat' and 'Cloudburst' is in the top left, and 'Google Earth' is in the bottom left. A scale bar for 90m is in the bottom right.</p>
40	Summary/Abstract	In the early morning of 14 th August 2023, a catastrophic debris flow event struck Juccain village which was triggered by headward landslide from incessant heavy rainfall on the nights of 12 th and 13 th August 2023 greatly impacting the community. The landslide characterised by debris material carrying large boulders was further exacerbated by flash floods sweeping away a significant portion of Gor road, numerous houses, cow sheds, a village school and vehicles. Critical observations revealed inadequate construction practices, notably building structures near first order streams, exacerbating the impact. The damage

		extended beyond the direct impact zone, affecting adjoining land masses and causing moderate landslides, disrupting communication in various areas. The study emphasizes the need for improved construction guidelines and early warning systems in vulnerable regions to mitigate the devastating effects of such disasters.
41	Pdf	Attached
42	Landslide alert category	Category II



ANNEXURE III

**42 POINT GEOPARAMETRIC DATASHEET FOR TATIH VILLAGE
DIST.MANDI, HP**

No	Field	Description
1	Slide No	HP/MAN/53A13/2023/
2	State	Himachal Pradesh
3	District	Mandi
4	Toposheet No	53A/13
5	Slide Name	Tatih debris slide
6	NH/SH Location	Tatih Village
7	Latitude	31.704166 N
8	Longitude	76.723611 E
9	Length	±80 m (Max. as on date of field observation)
10	Width	±120 m (Max. as on date of field observation)
11	Height	±70 m (Max. as on date of field observation)
12	Area	±9600 m ² (Max. as on date of field observation)
13	Depth	>5m
14	Volume	±48000 m ³ (Max. as on date of field observation)
15	Run out distance	---
16	Type of Material	Debris
17	Type of movement	Slide
18	Rate of movement	Rapid
19	Activity	Active
20	Distribution	Enlarging
21	Style	Single
22	Failure mechanism	Deep rotational failure
23	History	Initiated on 14 th August 2023 (Morning)
24	Geomorphology	Lowly dissected hill
25	Geology	Brown sandstone and shale, Upper Siwalik Group
26	Structure	----
27	Land use/land cover	Settlement and Moderate vegetation
28	Hydrological condition	Damp
29	Triggering factor	Rainfall
30	Death of persons	---
31	People affected	Settlement on the crown portion and right and left flank of the incidence zone.
32	Live-stock loss	---
33	Communication	Local pavement and road located on the crown and toe portion damaged
34	Infrastructure	1 building collapse
35	Agriculture/forest /barren	---
36	Geoscientific Causes	i. The most important causative factor for the triggering and development of landslide is the continuous heavy rainfall

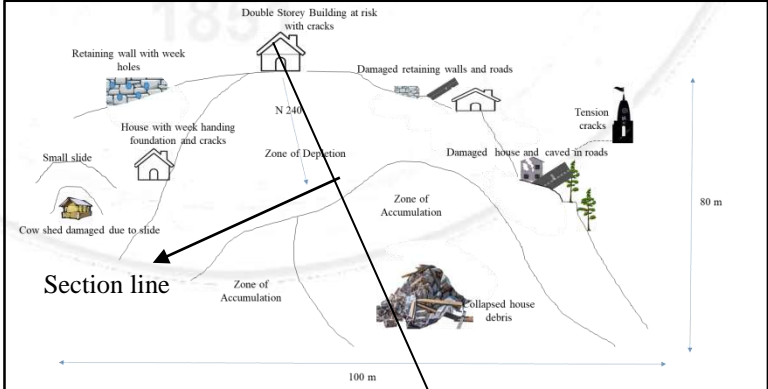
		and oversaturation of water within the fragile and loose material of slope forming material leading to slope failure.
37	Remedial measures	<ul style="list-style-type: none"> i. Proper channelization for water to avoid its further ingress at the earliest away from the sliding zone. ii. The up-slope hill mass and village establishments must be put to frequent observations with regards to any ground signature of instability such as developments of tension crack, joint openings/ widening, land sinking, development of crack in building, collapse of soil along slope or <i>nala</i>, tilting of trees, sudden appearance or disappearance of surface stream or reduction in water volume etc. iii. Immediate filling of transverse and contour parallel tension cracks with appropriate impervious material immediately. iv. Use of soil nailing, grouting, wire mesh draping, biotechnical slope stabilization measures (plantation of suitable trees with deep rooted species, application of geo-jute/geo-mats etc) in the slope debris mass of the uphill and downhill (road/ dump filling). v. People should be educated about the ill-effects of unscientific slope modifications to avoid slope failures in the future.
38	Remarks, if any	Tensional cracks developed on both the flanks of the slide zone.
39	Photos. Sketch of Plan & section of the slide	 <p style="text-align: center;">Fig 1:Debris slide</p>  <p style="text-align: center;">Fig 2: Schematic plan view of the slide zone.</p>

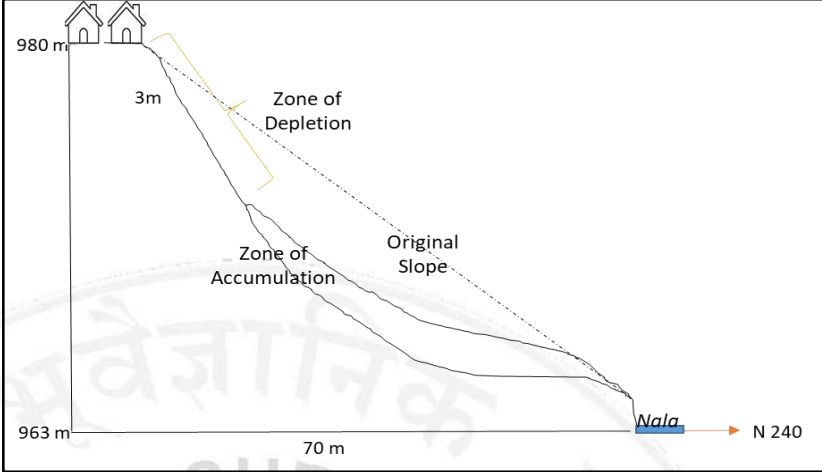
		 <p style="text-align: center;">Fig 3: Schematic section</p>
40	Summary/Abstract	<p>Tatih slide is a significant debris slide which resulted in loss of property, including roads, electrical infrastructure, residential structures, cow sheds etc. although there were no reported casualties, various houses experienced structural damage with visible cracks in their walls. The slide exhibits a retrogressive nature showcasing deep rotational failure of slope debris, as evidenced by transverse cracks in adjacent part of the slide zone. The slide was triggered by oversaturation of slope debris caused due to infiltration at the crown portion. Prolonged and intense rainfall coupled with the absence of drainage networks exacerbated the slope instability, ultimately leading to the slope failure. The preliminary studies indicate the critical importance of proper slope management and drainage systems to mitigate landslide risks in vulnerable regions.</p>
41	Pdf	Attached
42	Landslide alert category	Category I

ANNEXURE IV

**42 POINT GEOPARAMETRIC DATASHEET FOR NARERI CLOUDBURST,
DIST.MANDI, HP**

No	Field	Description
1	Slide No	HP/MAN/53A/13/2023/
2	State	Himachal Pradesh
3	District	Mandi
4	Toposheet No	53A/13
5	Slide Name	Narera Cloudburst
6	NH/SH Location	Narera Village
7	Latitude	31.793055 N
8	Longitude	76.780555 E
9	Length	±110 m (Max. as on date of field observation)
10	Width	±460 m (Max. as on date of field observation)
11	Height	±90 m (Max. as on date of field observation)
12	Area	---
13	Depth	>5m
14	Volume	---
15	Run out distance	---
16	Type of Material	Debris
17	Type of movement	Flow
18	Rate of movement	Extremely Rapid
19	Activity	Active
20	Distribution	Widening
21	Style	Single
22	Failure mechanism	Deep rotational failure
23	History	Initiated on 14 th August 2023 (06:30 hrs)
24	Geomorphology	Lowly dissected hill slope
25	Geology	Sandstone and purple shale, Dakshai Formation, Sirmur Group
26	Structure	--
27	Land use/land cover	Settlement (Right and left flank) and Moderate to dense vegetation
28	Hydrological condition	Flowing
29	Triggering factor	Cloudburst
30	Death of persons	---
31	People affected	Locals residing along the right and left flank of the incidence zone.
32	Live-stock loss	1 Buffalo and 4 Goats
33	Communication	NH-03 washed out (Nala flowing along NH)
34	Infrastructure	Washing away of several major houses and agricultural land located on the vicinity of the slide zone.
35	Agriculture/forest /barren	Agriculture.
36	Geoscientific Causes	<ul style="list-style-type: none"> i. Saturation of water within the fragile and loose material of slope forming material during heavy precipitation. ii. The damage was caused by a flash flood charged with

		debris flow in the upslope incised gully triggered by head ward landslide due to incessant heavy rainfall during previous days (i.e 12 & 13 th August 2023).
37	Remedial measures	<ol style="list-style-type: none"> i. Rehabilitation of affected inhabitants of Narera village and adjoining area to a safer place in view of destabilize ground condition and possible recurrence of incidence at the village. ii. Provision of concrete lined spacious <i>nala</i> course with a provision of culvert on the road ensuring the easy passage of debris flow. iii. Concrete retaining structure all along the road stretch terrace/debris cone material with adequate drainage holes iv. Launch of landslide safety (vulnerability identification) programs in villages/habitat located in such fragile Geo-environmental area v. Settlement/construction for dwelling may be avoided along <i>nala/khad</i>/river banks or flood plain area and along the <i>nala</i> banks and dormant courses. vi. Suitable plantation/afforestation for the stabilization of <i>nala</i> banks and disturbed ground. vii. Identification of stable ground for safe construction and urbanization with proper drainage outlets and protection wall.
38	Remarks, if any	---
39	Photos. Sketch of Plan & section of the slide	 <p>Fig: Narera debris flow.</p>
40	Summary/Abstract	The debris flow on 14 th August 2023 at Narera village led to the loss of livestock, destruction of major houses and cow sheds and damage to a 90m stretch of NH-03, village roads and 50 bigah of agricultural lands. The event was triggered by heavy rainfall in the preceding nights, resulting in a flash flood charged with a debris flow in the upslope incised gully. The village experienced a similar flash flood incident on a smaller scale in 2014. The recent occurrence rendered adjoining areas unstable, affecting 25 families residing in the village. The flash flood split into three



		sublets at the downstream end, likely facilitating the spread of the debris flow across the village. The entire village landmass remains destabilised and necessitates proper ground stabilisation measures for reclamation. The preliminary study underscores the urgency of stabilizing and reclaiming the affected land to ensure the safety and livelihoods of the community.
41	Pdf	Attached
42	Landslide alert category	Category I



ANNEXURE V

**42 POINT GEOPARAMETRIC DATASHEET FOR RIYUR VILLAGE AND
ADJOINING AREA, DIST.MANDI, HP**

No	Field	Description
1	Slide No	HP/MAN/53A13/2023/
2	State	Himachal Pradesh
3	District	Mandi
4	Toposheet No	53A/13
5	Slide Name	Banal Slide
6	NH/SH Location	Banal village
7	Latitude	31.79333 N
8	Longitude	76.76222 E
9	Length	±80 m (Max. as on date of field observation)
10	Width	±50 m (Max. as on date of field observation)
11	Height	±70 m (Max. as on date of field observation)
12	Area	±4000 m ² (Max. as on date of field observation)
13	Depth	2-5m
14	Volume	±16000 m ³ (Max. as on date of field observation)
15	Run out distance	---
16	Type of Material	Debris
17	Type of movement	Slide (circular) and subsidence
18	Rate of movement	Rapid
19	Activity	Active
20	Distribution	Retrogressive and widening
21	Style	Multiple
22	Failure mechanism	Shallow rotational failure
23	History	Initiated on 14 th August 2023 (Morning)
24	Geomorphology	Lowly dissected hillslope
25	Geology	Sandstone and purple shale, Dakshai Formation, Sirmur Group
26	Structure	--
27	Land use/land cover	Moderate vegetation
28	Hydrological condition	Damp
29	Triggering factor	Rainfall
30	Death of persons	---
31	People affected	Settlements along Banal Village
32	Live-stock loss	---
33	Communication	Road subsidence (Broken/ damaged at places)
34	Infrastructure	Cracks on houses
35	Agriculture/forest /barren	Agriculture
36	Geoscientific Causes	i. Over saturation of water within the fragile and loose material of slope forming material due to heavy precipitation,

		<ul style="list-style-type: none"> ii. The surface indications of ground deformation in the form of ground cracks and bulging of gabion wall indicate that the whole slope mass is in distress.
37	Remedial measures	<ul style="list-style-type: none"> i. Removal of loose precarious boulders from the slide zone and at road level. i. Provision of retaining structure with staggered drains with weep holes at road level and cleaning of drains at regular interval. ii. It is observed that surface water seeps/ infiltrate into the slide zone so every effort should be made to ensure that the surface water is diverted from the slide slope face. Hence series of contour parallel drains should be placed above the crown so that ideally no water will be permitted to flow into the slide zone and a series of interconnected cross drains will help in flushing out the excess water during rainy days. iii. Sealing of fractures or cracks with impervious materials
38	Remarks, if any	.
39	Photos. Sketch of Plan & section of the slide	 <p>The photograph shows a dirt road that has significantly subsided on the right side, creating a deep, uneven depression. A black arrow points from the text 'To Banal Village' towards the road. The surrounding area is lush with green trees and vegetation.</p> <p>Fig 1: Road subsidence</p>  <p>The photograph shows a steep, rocky slope with a large area of exposed earth and rocks, indicating a debris slide. A red dashed line traces the top edge of the slide, with a red arrow pointing to it and the word 'Crown' written in yellow. A person is standing at the bottom left of the slope for scale.</p> <p>Fig 2: Debris Slide</p>
40	Summary/Abstract	<p>The signs of instability in the vicinity of Banal Village is evident by recurring road subsidence and debris slides occurring at an interval of approximately 100-200m. The causative cause is attributed towards the oversaturation of water due to intense precipitation. To mitigate these issues, initial measures are</p>

		recommended. These include the removal of loose and precarious boulders from the slide-prone areas and at road level. Additionally it is advisable to construct retaining structures equipped with staggered drains featuring weep holes at road level. Moreover, a regular maintenance schedule should be established for cleaning the drains to ensure their optimal functionality and prevent future incidents.
41	Pdf	Attached
42	Landslide alert category	Category II

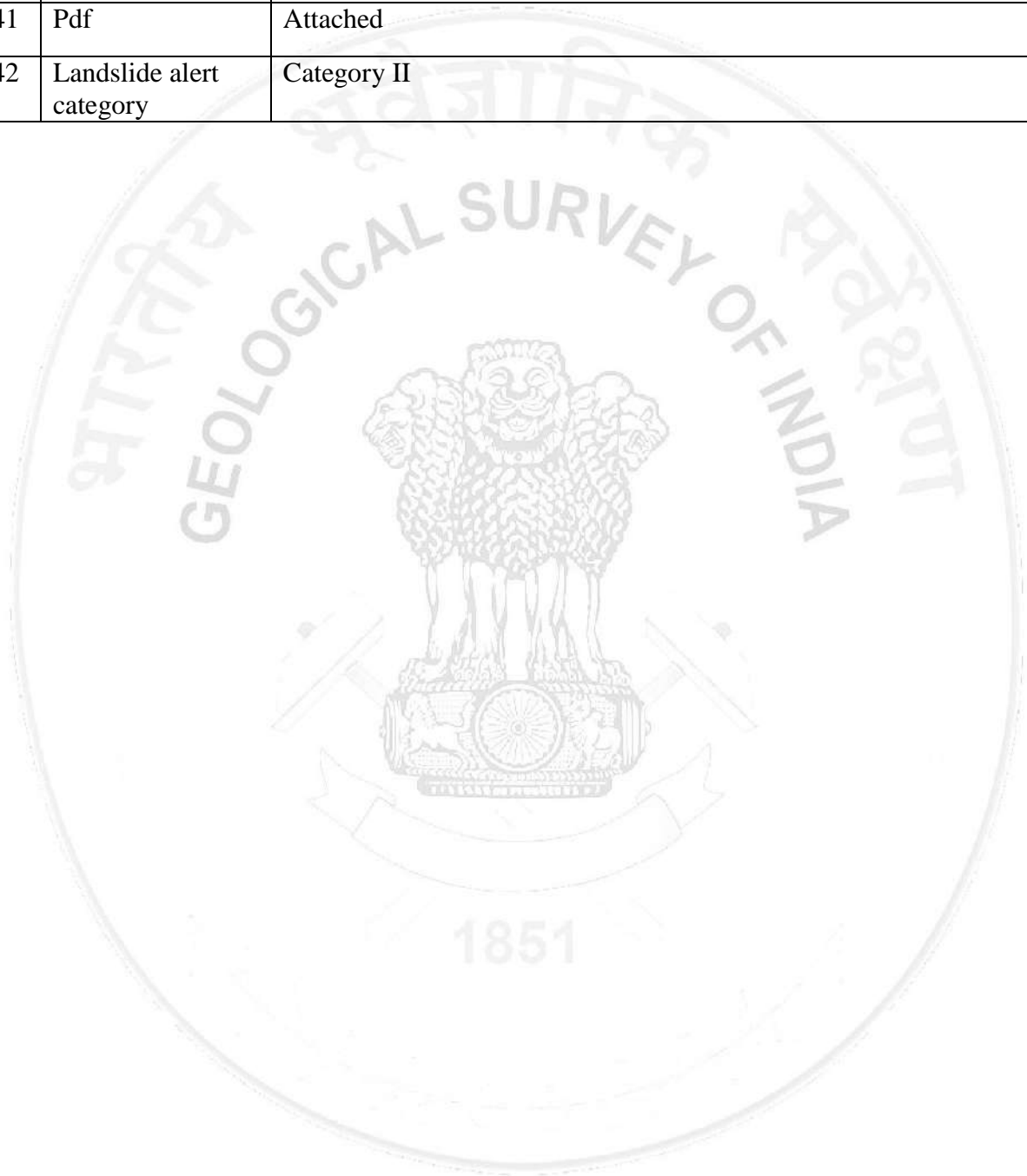

No	Field	Description
1	Slide No	HP/MAN/53A13/2023/
2	State	Himachal Pradesh
3	District	Mandi
4	Toposheet No	53A/13
5	Slide Name	---
6	NH/SH Location	Banal village
7	Latitude	31.78944 N
8	Longitude	76.75555 E
9	Length	±60 m (Max. as on date of field observation)
10	Width	±80 m (Max. as on date of field observation)
11	Height	±50 m (Max. as on date of field observation)
12	Area	±4800 m ² (Max. as on date of field observation)
13	Depth	2-5m
14	Volume	±24000 m ³ (Max. as on date of field observation)
15	Run out distance	---
16	Type of Material	Debris
17	Type of movement	Slide (circular) and road subsidence
18	Rate of movement	Rapid
19	Activity	Active
20	Distribution	Retrogressive
21	Style	Single
22	Failure mechanism	Shallow rotational failure
23	History	Initiated on 13 th and 14 th August 2023 (Morning)
24	Geomorphology	Lowly dissected hillslope
25	Geology	Sandstone and purple shale, Dakshai Formation, Sirmur Group
26	Structure	--
27	Land use/land cover	Settlement and Agriculture
28	Hydrological condition	Damp
29	Triggering factor	Rainfall
30	Death of persons	--
31	People affected	Banal residence
32	Live-stock loss	---
33	Communication	Road damaged every 10m
34	Infrastructure	Cracks on houses
35	Agriculture/forest/barren	Agriculture
36	Geoscientific Causes	<ul style="list-style-type: none"> i. Over saturation of water within the fragile and loose material of slope forming material due to heavy precipitation, ii. The surface indications of ground deformation in the form of ground cracks and bulging of gabion wall indicate that the whole slope mass is in distress.
37	Remedial measures	<ul style="list-style-type: none"> i. Removal of loose precarious boulders from the slide zone and at road level. ii. Provision of retaining structure with staggered drains with weep holes at road level and cleaning of drains at regular interval.

		<p>iii. It is observed that surface water seeps/ infiltrate into the slide zone so every effort should be made to ensure that the surface water is diverted from the slide slope face. Hence series of contour parallel drains should be placed above the crown so that ideally no water will be permitted to flow into the slide zone and a series of interconnected cross drains will help in flushing out the excess water during rainy days.</p> <p>iv. Sealing of fractures or cracks with impervious materials.</p>
38	Remarks, if any	In every 10m interval around the village, there is occurrence of slide and road subsidence.
39	Photos. Sketch of Plan & section of the slide	 <p>Fig 1: Road damaged</p>

		 <p data-bbox="571 1137 798 1171">Fig 2:Debris slide</p>
40	Summary/Abstract	<p>The signs of instability in the vicinity of Banal Village is evident by recurring road subsidence and debris slides occurring at an interval of approximately 100-200m. The causative cause is attributed towards the oversaturation of water due to intense precipitation. To mitigate these issues, initial measures are recommended. These include the removal of loose and precarious boulders from the slide-prone areas and at road level. Additionally it is advisable to construct retaining structures equipped with staggered drains featuring weep holes at road level. Moreover, a regular maintenance schedule should be established for cleaning the drains to ensure their optimal functionality and prevent future incidents.</p>
41	Pdf	Attached
42	Landslide alert category	Category II

No	Field	Description
1	Slide No	HP/MAN/53A13/2023/
2	State	Himachal Pradesh
3	District	Mandi
4	Toposheet No	53A/13
5	Slide Name	---
6	NH/SH Location	Banal village
7	Latitude	31.789722 N
8	Longitude	76.754722 E
9	Length	±80 m (Max. as on date of field observation)
10	Width	±30 m (Max. as on date of field observation)
11	Height	±70 m (Max. as on date of field observation)
12	Area	±2400 m ² (Max. as on date of field observation)
13	Depth	>5m
14	Volume	±12500 m ³ (Max. as on date of field observation)
15	Run out distance	---
16	Type of Material	Debris
17	Type of movement	Slide (circular)
18	Rate of movement	Rapid
19	Activity	Active
20	Distribution	Retrogressive
21	Style	Single
22	Failure mechanism	Deep rotational failure
23	History	Initiated on 14 th August 2023 (Morning)
24	Geomorphology	Lowly dissected hillslope
25	Geology	Sandstone and purple shale, Dakshai Formation, Sirmur Group
26	Structure	---
27	Land use/land cover	Moderate Vegetation and Agriculture
28	Hydrological condition	Damp
29	Triggering factor	Rainfall
30	Death of persons	---
31	People affected	Banal residence
32	Live-stock loss	---
33	Communication	Road damaged
34	Infrastructure	Cracks on houses
35	Agriculture/forest/barren	Agriculture
36	Geoscientific Causes	<ul style="list-style-type: none"> i. Over saturation of water within the fragile and loose material of slope forming material due to heavy precipitation, ii. The surface indications of ground deformation in the form of ground cracks and bulging of gabion wall indicate that the whole slope mass is in distress.
37	Remedial measures	<ul style="list-style-type: none"> i. Removal of loose precarious boulders from the slide zone and at road level. ii. Provision of retaining structure with staggered drains with weep holes at road level and cleaning of drains at regular interval.

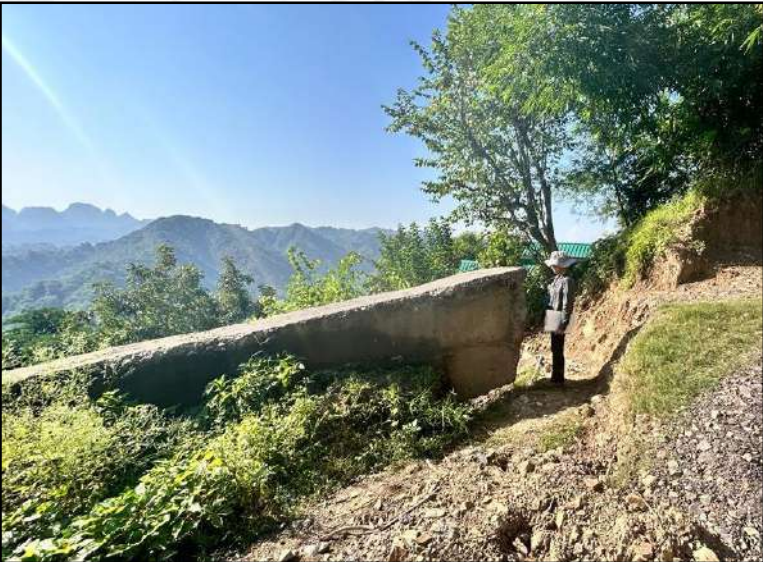
		<p>iii. It is observed that surface water seeps/ infiltrate into the slide zone so every effort should be made to ensure that the surface water is diverted from the slide slope face. Hence series of contour parallel drains should be placed above the crown so that ideally no water will be permitted to flow into the slide zone and a series of interconnected cross drains will help in flushing out the excess water during rainy days.</p> <p>iv. Sealing of fractures or cracks with impervious materials.</p>
38	Remarks, if any	House damaged and cracks developed in some settlement. Subsidence of retaining wall given below road bench.
39	Photos. Sketch of Plan & section of the slide	 <p>Fig 1: Damaged concrete retaining wall.</p>
40	Summary/Abstract	<p>Instability is evident through structural damage to houses and the formation of cracks in certain settlements. Additionally, there has been subsidence of the retaining wall beneath the road bench. Furthermore, surface water infiltration into the slide zone has been observed emphasizing the need to divert surface water from the slope face to mitigate potential damage. To achieve this, it is recommended to implement a system of contour-parallel drains above the crown which will prevent any surface water infiltration from entering the slide zone. Moreover, a network of interconnected cross drains will aid in effectively channeling excess water out of the area, particularly during rainy season.</p>
41	Pdf	Attached
42	Landslide alert category	Category II

No	Field	Description
1	Slide No	HP/MAN/53A13/2023/
2	State	Himachal Pradesh
3	District	Mandi
4	Toposheet No	53A/13
5	Slide Name	---
6	NH/SH Location	Riyur village
7	Latitude	31.782631 N
8	Longitude	76.755115 E
9	Length	±80 m (Max. as on date of field observation)
10	Width	±30 m (Max. as on date of field observation)
11	Height	±70 m (Max. as on date of field observation)
12	Area	±24000 m ² (Max. as on date of field observation)
13	Depth	2-5m
14	Volume	±9600 m ³ (Max. as on date of field observation)
15	Run out distance	---
16	Type of Material	Debris
17	Type of movement	Slide (circular) and subsidence
18	Rate of movement	Rapid
19	Activity	Active
20	Distribution	Advancing
21	Style	Multiple
22	Failure mechanism	Shallow rotational failure
23	History	Initiated on 14 th August 2023 (Morning)
24	Geomorphology	Lowly dissected hillslope
25	Geology	Sandstone and purple shale, Dakshai Formation, Sirmur Group
26	Structure	---
27	Land use/land cover	Settlement
28	Hydrological condition	Damp
29	Triggering factor	Rainfall
30	Death of persons	---
31	People affected	Settlements
32	Live-stock loss	---
33	Communication	Road damaged
34	Infrastructure	Cracks on houses
35	Agriculture/forest/b arren	Agriculture
36	Geoscientific Causes	<ul style="list-style-type: none"> i. Over saturation of water within the fragile and loose material of slope forming material due to heavy precipitation, ii. The surface indications of ground deformation in the form of ground cracks and bulging of gabion wall indicate that the whole slope mass is in distress.
37	Remedial measures	<ul style="list-style-type: none"> i. Removal of loose precarious boulders from the slide zone. ii. Provision of retaining structure with staggered drains with weep holes at road level and along vulnerable part of

		<p>the slope and cleaning of drains at regular interval</p> <p>iii. It is observed that surface water seeps/ infiltrate into the slide zone so every effort should be made to ensure that the surface water is diverted from the slide slope face. Hence series of contour parallel drains should be placed above the crown so that ideally no water will be permitted to flow into the slide zone and a series of interconnected cross drains will help in flushing out the excess water during rainy days.</p> <p>iv. Sealing of fractures or cracks with impervious materials.</p> <p>v. Installation of Rain gauge and monitoring devices to constantly track ground movements, slope stability and soil moisture levels for timely intervention and hazard mitigation.</p> <p>vi. Improve drainage system to efficiently manage surface water runoff, mitigating the risk of slope destabilization. Design proper drainage channels to help direct water away from vulnerable areas.</p>
38	Remarks, if any	House damaged and cracks developed in some settlement.
39	Photos. Sketch of Plan & section of the slide	 <p>Fig 1: Cracks on settlements .</p>



Fig 2: Road subsidence (± 2.5 feet)



Fig 3: House damaged by slide.

40	Summary/Abstract	<p>The slope instability in Riyur village is indicated by visible cracks in numerous houses lining the slope, with one residence near the crown suffering significant damage. Geoscientifically, this instability is attributed to the oversaturation of water within the slope forming material .to address these concerns and proactively manage potential hazards, the following preliminary measures are recommended- installation of rain gauge and other monitoring devices to track ground movements, slope stability and soil moisture levels. Secondly, by enhancing the existing drainage system to efficiently handle surface water runoff thus mitigating the risk of slope destabilization.</p>
41	Pdf	Attached
42	Landslide alert category	Category II

No	Field	Description
1	Slide No	HP/MAN/53A13/2023/
2	State	Himachal Pradesh
3	District	Mandi
4	Toposheet No	53A/13
5	Slide Name	---
6	NH/SH Location	Near Kamksha Devi Temple, Didnu road
7	Latitude	31°46'56"N
8	Longitude	76°45'2"E
9	Length	±60 m (Max. as on date of field observation)
10	Width	±50 m (Max. as on date of field observation)
11	Height	±45 m (Max. as on date of field observation)
12	Area	±3000 m ² (Max. as on date of field observation)
13	Depth	2-5m
14	Volume	±12000 m ³ (Max. as on date of field observation)
15	Run out distance	---
16	Type of Material	Debris
17	Type of movement	Slide (circular) and subsidence
18	Rate of movement	Rapid
19	Activity	Active
20	Distribution	Retrogressive
21	Style	Single
22	Failure mechanism	Shallow rotational failure
23	History	14 th August 2023 (Morning)
24	Geomorphology	Lowly dissected hillslope
25	Geology	Sandstone and purple shale, Dakshai Formation, Sirmur Group
26	Structure	---
27	Land use/land cover	Moderate vegetation
28	Hydrological condition	Damp
29	Triggering factor	Rainfall
30	Death of persons	---
31	People affected	---
32	Live-stock loss	---
33	Communication	Road damaged
34	Infrastructure	---
35	Agriculture/forest/b arren	---
36	Geoscientific Causes	<ul style="list-style-type: none"> i. Over saturation of water within the fragile and loose material of slope forming material due to heavy precipitation, ii. The surface indications of ground deformation in the form of ground cracks and bulging of gabion wall indicate that the whole slope mass is in distress.
37	Remedial measures	<ul style="list-style-type: none"> i. Removal of loose precarious boulders from the slide zone and at road level. ii. Provision of retaining structure with staggered drains

		<p>with weep holes at road level and cleaning of drains at regular interval.</p> <p>iii. It is observed that surface water seeps/ infiltrate into the slide zone so every effort should be made to ensure that the surface water is diverted from the slide slope face. Hence series of contour parallel drains should be placed above the crown so that ideally no water will be permitted to flow into the slide zone and a series of interconnected cross drains will help in flushing out the excess water during rainy days.</p> <p>iv. Sealing of fractures or cracks with impervious materials.</p>
38	Remarks, if any	Concrete retaining wall damaged, water pipeline passing through the slide zone damaged.
39	Photos. Sketch of Plan & section of the slide	 <p>Fig 1 :Debris slide</p>
40	Summary/Abstract	This slide is caused due to over saturation of water within the fragile and loose material of slope forming material due to heavy precipitation which has damaged the concrete retaining wall and water pipeline passing through the slide zone. For preliminary measures removal of loose precarious boulders from the slide zone and at road level and provision of retaining structure with staggered drains with weep holes at road level and cleaning of drains at regular interval has been recommended.
41	Pdf	Attached
42	Landslide alert category	Category II

No	Field	Description
1	Slide No	HP/MAN/53A13/2023/
2	State	Himachal Pradesh
3	District	Mandi
4	Toposheet No	53A/13
5	Slide Name	---
6	NH/SH Location	Didnu road
7	Latitude	31.781418 N
8	Longitude	76.756217 E
9	Length	±20 m (Max. as on date of field observation)
10	Width	±20 m (Max. as on date of field observation)
11	Height	±15 m (Max. as on date of field observation)
12	Area	±400 m ² (Max. as on date of field observation)
13	Depth	2-5m
14	Volume	±2000 m ³ (Max. as on date of field observation)
15	Run out distance	---
16	Type of Material	Debris
17	Type of movement	Slide
18	Rate of movement	Rapid
19	Activity	Active
20	Distribution	Retrogressive
21	Style	Multiple
22	Failure mechanism	Shallow rotational failure
23	History	14 th August 2023 (Morning)
24	Geomorphology	Lowly dissected hillslope
25	Geology	Sandstone and purple shale, Dakshai Formation, Sirmur Group
26	Structure	S ₀ // J ₁ =70°/N261°, J ₂ =85°/N003°, J ₃ =60°/N96°
27	Land use/land cover	Settlement and Moderate vegetation
28	Hydrological condition	Damp
29	Triggering factor	Rainfall
30	Death of persons	---
31	People affected	Residence around the slide zone
32	Live-stock loss	---
33	Communication	Road damaged
34	Infrastructure	Cracks on houses
35	Agriculture/forest/barr en	Agriculture
36	Geoscientific Causes	i. Over saturation of water within the fragile and loose material of slope forming material due to heavy precipitation,
37	Remedial measures	i. Removal of loose precarious boulders from the slide zone and at road level. ii. Provision of retaining structure with staggered drains with weep holes at road level and cleaning of drains at regular interval.
38	Remarks, if any	Cracks on houses situated above the crown

39	Photos. Sketch of Plan & section of the slide	 <p data-bbox="587 640 1171 674">Fig: House damaged due to debris slide zone.</p>
40	Summary/Abstract	<p data-bbox="587 678 1399 857">This is a debris slide of smaller dimension, but it has inflicted significant damage on the nearby settlements. The causative factor is due to Over saturation of water within the fragile and loose material of slope forming material due to heavy precipitation.</p>
o4 1	Pdf	Attached
42	Landslide alert category	Category II

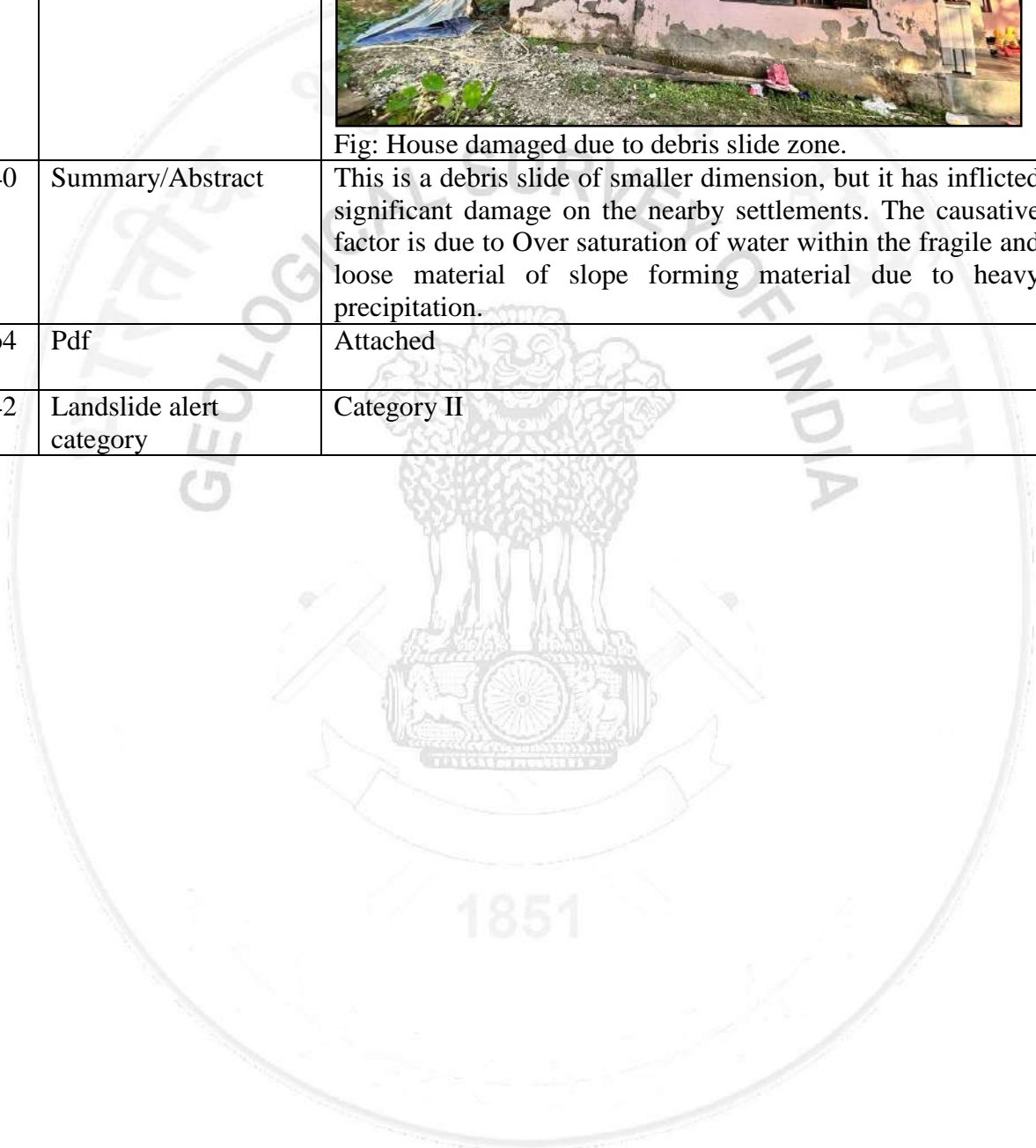

No	Field	Description
1	Slide No	HP/MAN/53A13/2023/
2	State	Himachal Pradesh
3	District	Mandi
4	Toposheet No	53A/13
5	Slide Name	Didnu Debris Slide
6	NH/SH Location	Didnu road
7	Latitude	31.78000 N
8	Longitude	76.77055 E
9	Length	±150 m (Max. as on date of field observation)
10	Width	±100 m (Max. as on date of field observation)
11	Height	±140 m (Max. as on date of field observation)
12	Area	±15000 m ² (Max. as on date of field observation)
13	Depth	>5m
14	Volume	±75000 m ³ (Max. as on date of field observation)
15	Run out distance	±200 m (Max. as on date of field observation upto river)
16	Type of Material	Debris
17	Type of movement	Slide
18	Rate of movement	Rapid
19	Activity	Active
20	Distribution	Enlarging
21	Style	Multiple
22	Failure mechanism	Deep rotational failure
23	History	14 th August 2023 (Morning)
24	Geomorphology	Lowly dissected hillslope
25	Geology	Sandstone and purple shale, Dakshai Formation, Sirmur Group
26	Structure	S ₀ // J ₁ =10°/N300°, J ₂ =85°/N100°, J ₃ =65°/N175°
27	Land use/land cover	Settlement and Moderate vegetation
28	Hydrological condition	Damp and flowing <i>nala</i> within the slide zone (As observed during field studies)
29	Triggering factor	Rainfall
30	Death of persons	---
31	People affected	Settlements around the slide zone
32	Live-stock loss	---
33	Communication	Road damaged (±5 feet road subsided)
34	Infrastructure	2 house damaged and cracks on houses situated above the crown
35	Agriculture/forest /barren	Agriculture
36	Geoscientific Causes	i. Over saturation of unconsolidated slope material due to heavy precipitation.
37	Remedial measures	i. It is observed that surface water seeps/ infiltrate into the slide zone so every effort should be made to ensure that the surface water is diverted from the slide slope face. Hence series of contour parallel drains should be placed above the crown so that ideally no water will be



		<p>permitted to flow into the slide zone and a series of interconnected cross drains will help in flushing out the excess water during rainy days.</p> <ul style="list-style-type: none"> ii. Provision of retaining wall with weep holes and toe train along the road. iii. It is recommended to modify the slope by benching. iv. Sealing of fractures or cracks with impervious materials.
38	Remarks, if any	
39	Photos. Sketch of Plan & section of the slide	 <p>Fig 1: House damaged</p>  <p>Fig 2: Cracks and sinking of settlement</p>



Fig 3: Prospective view of Didnu slide zone.

40	Summary/Abstract	It is a debris slide of larger dimension. The enlarging activities of the slide are mainly triggered by infiltration of rainwater resulting in increase in the pore water pressure and reduce in the shear strength. The debris material which is further aggravated by the presence of first order streams flowing within the slide zone causing deep rotational failure as per field observations.
41	Pdf	Attached
42	Landslide alert category	Category I

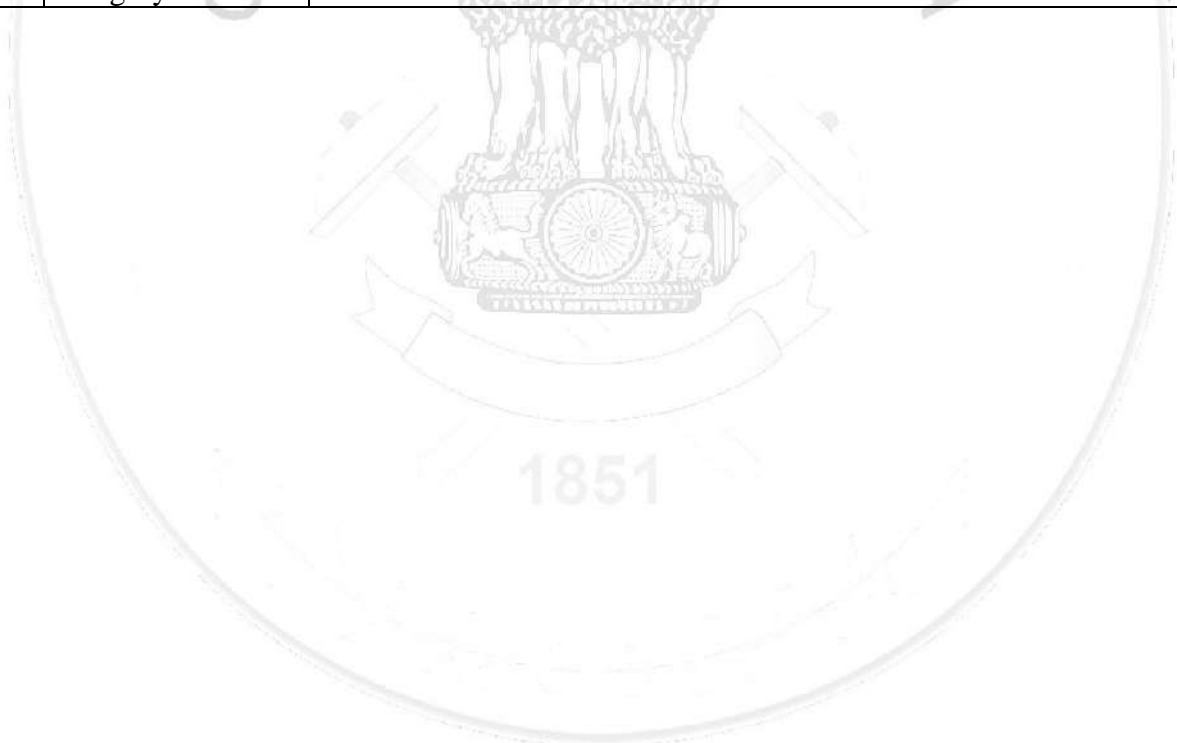

No	Field	Description
1	Slide No	HP/MAN/53A13/2023/
2	State	Himachal Pradesh
3	District	Mandi
4	Toposheet No	53A/13
5	Slide Name	Baral Slide
6	NH/SH Location	Baral Village, Riyur-Baroti Road
7	Latitude	31.78083 N
8	Longitude	76.77722 E
9	Length	±80 m (Max. as on date of field observation)
10	Width	±100 m (Max. as on date of field observation)
11	Height	±70 m (Max. as on date of field observation)
12	Area	±8000 m ² (Max. as on date of field observation)
13	Depth	>5m
14	Volume	±43000 m ³ (Max. as on date of field observation)
15	Run out distance	±50 m (Max. as on date of field observation upto river)
16	Type of Material	Debris
17	Type of movement	Slide and subsidence
18	Rate of movement	Rapid
19	Activity	Active
20	Distribution	Enlarging
21	Style	Multiple
22	Failure mechanism	Deep rotational failure
23	History	14 th August 2023 (Morning)
24	Geomorphology	Lowly dissected hillslope
25	Geology	Sandstone and purple shale, Dakshai Formation, Sirmur Group
26	Structure	S ₀ // J ₁ =10°/N300°, J ₂ =85°/N100°, J ₃ =65°/N175°
27	Land use/land cover	Settlement and Moderate vegetation
28	Hydrological condition	Damp and flowing <i>nala</i> within the slide zone (As observed during field studies)
29	Triggering factor	Rainfall
30	Death of persons	---
31	People affected	Settlements located along the vicinity of the slide zone.
32	Live-stock loss	
33	Communication	Road subsided and blocked at places around Baral Village
34	Infrastructure	School building damaged.
35	Agriculture/forest /barren	Forest
36	Geoscientific Causes	i. Over saturation of unconsolidated slope material due to heavy precipitation.
37	Remedial measures	i. Removal of loose precarious boulders from the slide zone and at road level. ii. Provision of gabion wall all along the road bench and cleaning of drains at regular interval.
38	Remarks, if any	



39	Photos. Sketch of Plan & section of the slide	 <p data-bbox="531 1144 762 1173">Fig 1:Debris slide</p>
40	Summary/Abstract	<p data-bbox="531 1180 1398 1688">The signs of instability in the vicinity of Baral Village is evident by recurring road subsidence and debris slides occurring at an interval of approximately 200m interval. The causative cause is attributed towards the oversaturation of water due to intense precipitation. The multiple crown of the slide are mainly triggered by infiltration of rainwater resulting in increase in the pore water pressure and reduce in the shear strength. To mitigate these issues, initial measures are recommended. These include the removal of loose and precarious boulders from the slide-prone areas and at road level. Additionally it is advisable to construct retaining structures equipped with staggered drains featuring weep holes at road level. Moreover, a regular maintenance schedule should be established for cleaning the drains to ensure their optimal functionality and prevent future incidents.</p>
41	Pdf	Attached
42	Landslide alert category	Category II

No	Field	Description
1	Slide No	HP/MAN/53A13/2023/
2	State	Himachal Pradesh
3	District	Mandi
4	Toposheet No	53A/13
5	Slide Name	---
6	NH/SH Location	Near PWD Guest house, Baroti
7	Latitude	31°47'07"N
8	Longitude	76°46'59"E
9	Length	±50 m (Max. as on date of field observation)
10	Width	±20 m (Max. as on date of field observation)
11	Height	±40 m (Max. as on date of field observation)
12	Area	±100 m ² (Max. as on date of field observation)
13	Depth	2-5m
14	Volume	±500 m ³ (Max. as on date of field observation)
15	Run out distance	---
16	Type of Material	Debris
17	Type of movement	Slide
18	Rate of movement	Rapid
19	Activity	Active
20	Distribution	Retrogressive
21	Style	Single
22	Failure mechanism	Shallow rotational failure
23	History	14 th August 2023 (Morning)
24	Geomorphology	Lowly dissected hillslope
25	Geology	Sandstone and purple shale, Dakshai Formation, Sirmur Group
26	Structure	S ₀ // J ₁ =10°/N300°, J ₂ =85°/N100°, J ₃ =65°/N175°
27	Land use/land cover	Settlement and Moderate vegetation
28	Hydrological condition	Damp (As observed during field studies)
29	Triggering factor	Rainfall
30	Death of persons	---
31	People affected	Settlements located within the vicinity of the slide zone.
32	Live-stock loss	---
33	Communication	---
34	Infrastructure	House situated above the crown damaged.
35	Agriculture/forest/b arren	Forest
36	Geoscientific Causes	i. Over saturation of unconsolidated slope material due to heavy precipitation.
37	Remedial measures	i. Removal of loose precarious boulders from the slide zone ii. Construction of interconnected surface drains/ proper drainage system.
38	Remarks, if any	

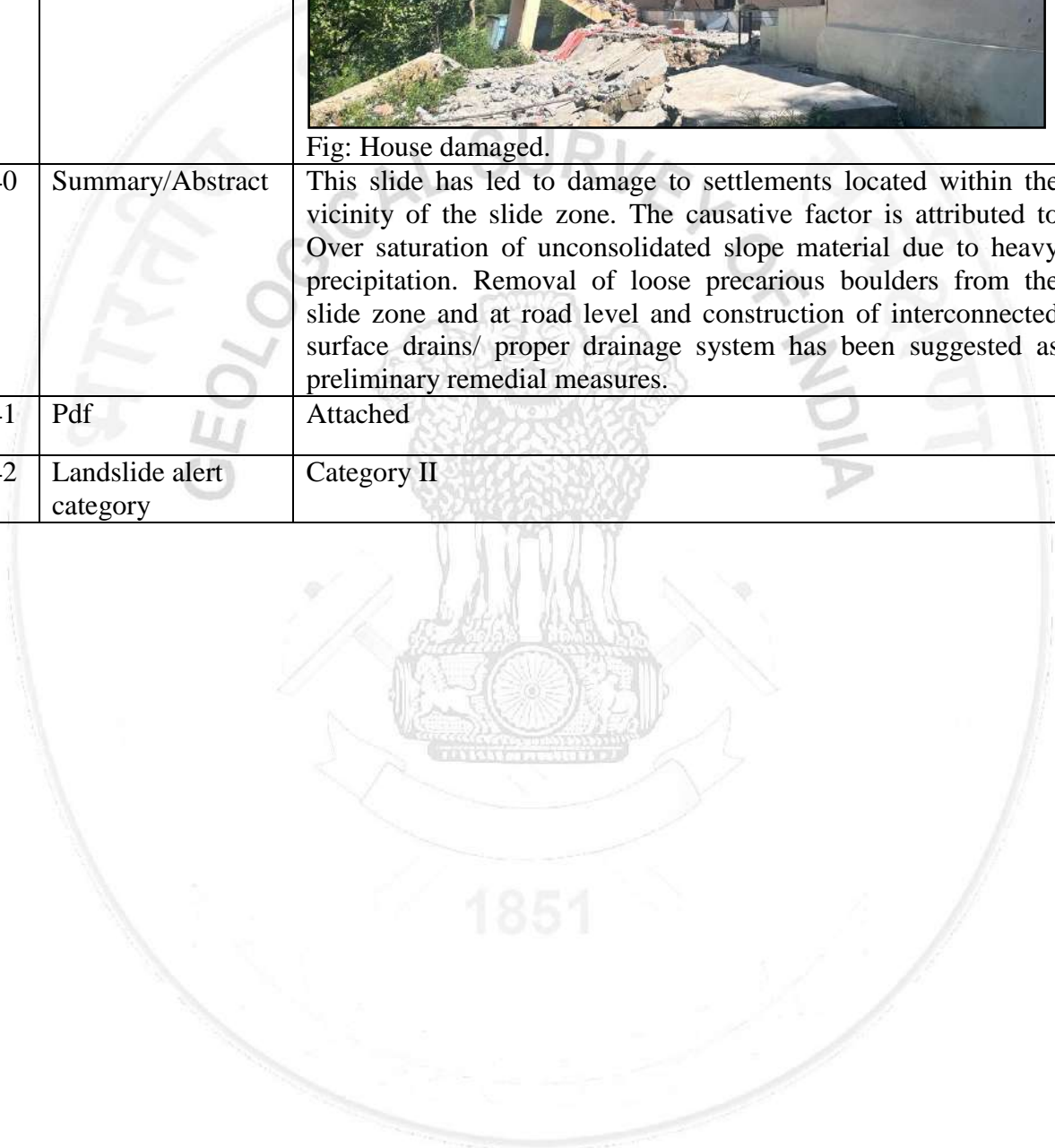
39	Photos. Sketch of Plan & section of the slide	 <p data-bbox="552 663 823 696">Fig: House damaged.</p>
40	Summary/Abstract	<p data-bbox="552 701 1398 954">This slide has led to damage to settlements located within the vicinity of the slide zone. The causative factor is attributed to Over saturation of unconsolidated slope material due to heavy precipitation. Removal of loose precarious boulders from the slide zone and at road level and construction of interconnected surface drains/ proper drainage system has been suggested as preliminary remedial measures.</p>
41	Pdf	Attached
42	Landslide alert category	Category II





No	Field	Description
1	Slide No	HP/MAN/53A13/2023/
2	State	Himachal Pradesh
3	District	Mandi
4	Toposheet No	53A/13
5	Slide Name	Maloh Slide
6	NH/SH Location	Maloh Village, NH-03
7	Latitude	31.79611 N
8	Longitude	76.78500 E
9	Length	±150 m (Max. as on date of field observation)
10	Width	±100 m (Max. as on date of field observation)
11	Height	±140 m (Max. as on date of field observation)
12	Area	±15000 m ² (Max. as on date of field observation)
13	Depth	>5m
14	Volume	±75000 m ³ (Max. as on date of field observation)
15	Run out distance	±60 m (Max. as on date of field observation)
16	Type of Material	Debris
17	Type of movement	Slide and subsidence
18	Rate of movement	Rapid
19	Activity	Active
20	Distribution	Enlarging
21	Style	Single
22	Failure mechanism	Deep rotational failure
23	History	14 th August 2023 (Morning)
24	Geomorphology	Lowly dissected hillslope
25	Geology	Sandstone and purple shale, Dakshai Formation, Sirmur Group
26	Structure	---
27	Land use/land cover	Moderate vegetation
28	Hydrological condition	Damp and flowing <i>nala</i> within the slide zone (As observed during field studies)
29	Triggering factor	Rainfall
30	Death of persons	---
31	People affected	Settlements located around the vicinity of the slide zone
32	Live-stock loss	---
33	Communication	Road subsided and blocked at places around Maloh Village
34	Infrastructure	Cracks on houses located in vicinity to the slide zone.
35	Agriculture/forest/barren	Agriculture
36	Geoscientific Causes	i. Over saturation of unconsolidated slope material due to heavy precipitation.
37	Remedial measures	i. Removal of loose precarious boulders from the slide zone and at road level. ii. Sealing of all ground cracks by impervious material such as clay, or placing jute clothe moistened with coal tar inside the cracks, so that surface water is prevented to a large extent to enter into the cracks. iii. Provision of proper retaining structure with staggered drains with weep holes on the slopes along the right flank of the slide zone.

38	Remarks, if any	---
39	Photos. Sketch of Plan & section of the slide	 <p>Fig 1: Prospective view of Maloh landslide.</p>  <p>Fig 2: Transverse cracks on the right flank of the slide zone.</p>
40	Summary/Abstract	<p>This is a major debris slide which has led to road subsidence at places around Maloh Village. The enlarging activities of the slide are mainly triggered by infiltration of rainwater resulting in increase in the pore water pressure and reduce in the shear strength. Ground cracks were observed on the right flank of the slide zone. Removal of loose precarious boulders from the slide zone and at road level, provision of gabion wall all along the road bench and cleaning of drains at regular interval and sealing of all ground cracks by impervious material has been suggested as preliminary remedial measures.</p>
41	Pdf	Attached
42	Landslide alert category	Category II

No	Field	Description
1	Slide No	HP/MAN/53A13/2023/
2	State	Himachal Pradesh
3	District	Mandi
4	Toposheet No	53A/13
5	Slide Name	Langerh Slide
6	NH/SH Location	Langerh Village, Baroti-Langerh road.
7	Latitude	31.783611 N
8	Longitude	76.78250 E
9	Length	±70 m (Max. as on date of field observation)
10	Width	±100 m (Max. as on date of field observation)
11	Height	±60 m (Max. as on date of field observation)
12	Area	±7000 m ² (Max. as on date of field observation)
13	Depth	>5m
14	Volume	±35000 m ³ (Max. as on date of field observation)
15	Run out distance	---
16	Type of Material	Debris
17	Type of movement	Slide
18	Rate of movement	Rapid
19	Activity	Active
20	Distribution	Enlarging
21	Style	Single
22	Failure mechanism	Shallow rotational failure.
23	History	14 th August 2023 (Morning)
24	Geomorphology	Lowly dissected hillslope
25	Geology	Sandstone and purple shale, Dakshai Formation, Sirmur Group
26	Structure	---
27	Land use/land cover	Agriculture
28	Hydrological condition	Damp (As observed during field studies)
29	Triggering factor	Rainfall
30	Death of persons	---
31	People affected	Settlements
32	Live-stock loss	---
33	Communication	---
34	Infrastructure	Cracks on houses
35	Agriculture/forest/b arren	Agriculture
36	Geoscientific Causes	i. Over saturation of unconsolidated slope material due to heavy precipitation.
37	Remedial measures	i. Removal of loose precarious boulders from the slide zone and at road level. ii. Attempts should be made to seal all ground cracks above by impervious material such as clay, or placing jute clothe moistened with coal tar inside the cracks, so that surface water is prevented to a large extent to enter into the cracks. iii. Provision of proper retaining structure with staggered

		drains with weep holes on the slopes along the right flank of the slide zone.
38	Remarks, if any	---
39	Photos. Sketch of Plan & section of the slide	 <p>Fig: Ground crack.</p>
40	Summary/Abstract	The instability along Langerh Village is evident by the presence of transverse cracks along the agricultural land .The enlarging activities of the slide are mainly triggered by infiltration of rainwater resulting in increase in the pore water pressure and reduce in the shear strength. Sealing of all ground cracks by impervious material has been suggested as preliminary remedial measures.
41	Pdf	Attached
42	Landslide alert category	Category II

No	Field	Description
1	Slide No	HP/MAN/53A13/2023/
2	State	Himachal Pradesh
3	District	Mandi
4	Toposheet No	53A/13
5	Slide Name	Brahma Falad Slide
6	NH/SH Location	Brahma Falad Village, Mandap road
7	Latitude	31.756241 N
8	Longitude	76.791823 E
9	Length	±100 m (Max. as on date of field observation)
10	Width	±80 m (Max. as on date of field observation)
11	Height	±90 m (Max. as on date of field observation)
12	Area	±8000 m ² (Max. as on date of field observation)
13	Depth	2-5m
14	Volume	±45000 m ³ (Max. as on date of field observation)
15	Run out distance	---
16	Type of Material	Debris
17	Type of movement	Slide and subsidence
18	Rate of movement	Rapid
19	Activity	Active
20	Distribution	Enlarging
21	Style	Single
22	Failure mechanism	Shallow rotational failure
23	History	14 th August 2023 (Morning)
24	Geomorphology	Lowly dissected hillslope
25	Geology	Sandstone and purple shale, Dakshai Formation, Sirmur Group
26	Structure	---
27	Land use/land cover	Moderate vegetation and settlement
28	Hydrological condition	Damp (As observed during field studies)
29	Triggering factor	Rainfall
30	Death of persons	---
31	People affected	Settlements
32	Live-stock loss	---
33	Communication	Road subsided
34	Infrastructure	Collapse of one underconstruction building. Cracks on houses located in vicinity to the slide zone.
35	Agriculture/forest /barren	Agriculture
36	Geoscientific Causes	i. Over saturation of unconsolidated slope material due to heavy precipitation.
37	Remedial measures	i. Removal of loose precarious boulders from the slide zone and at road level. ii. Provision of gabion wall all along the affected slopes and cleaning of drains at regular interval.

		<p>iii. Sealing of ground cracks with impervious material.</p> <p>iv. Construction of interconnected surface drains/ proper drainage system.</p>
38	Remarks, if any	
39	Photos. Sketch of Plan & section of the slide	 <p>Fig: Building collapse site.</p>  <p>Fig 2 : Road subsidence.</p>
40	Summary/Abstract	<p>The slope instability in Brahma Falad village is evident by the collapse of one underconstruction building and cracks on houses located around the vicinity of the slide zone. The main causative caused is due to over saturation of unconsolidated slope material due to heavy precipitation. Removal of loose precarious boulders from the slide zone and at road level.</p> <p>Provision of gabion wall all along the affected slopes and cleaning of drains at regular interval, sealing of ground cracks with impervious material and construction of interconnected surface drains/ proper drainage system has been suggested as preliminary remedial measures.</p>
41	Pdf	Attached
42	Landslide alert category	Category II

No	Field	Description
1	Slide No	HP/MAN/53A13/2023/
2	State	Himachal Pradesh
3	District	Mandi
4	Toposheet No	53A/13
5	Slide Name	Chanauta Slide
6	NH/SH Location	Chanauta Village
7	Latitude	31.75833 N
8	Longitude	76.773055 E
9	Length	±50 m (Max. as on date of field observation)
10	Width	±50 m (Max. as on date of field observation)
11	Height	±40 m (Max. as on date of field observation)
12	Area	±2500 m ² (Max. as on date of field observation)
13	Depth	2-5m
14	Volume	±10000 m ³ (Max. as on date of field observation)
15	Run out distance	---
16	Type of Material	Debris
17	Type of movement	subsidence
18	Rate of movement	Slow
19	Activity	Active
20	Distribution	Enlarging
21	Style	Single
22	Failure mechanism	Shallow rotational failure
23	History	14 th August 2023 (Morning)
24	Geomorphology	Lowly dissected hillslope
25	Geology	Sandstone and purple shale, Dakshai Formation, Sirmur Group
26	Structure	---
27	Land use/land cover	Dense vegetation
28	Hydrological condition	Damp (As observed during field studies)
29	Triggering factor	Rainfall
30	Death of persons	---
31	People affected	---
32	Live-stock loss	---
33	Communication	Road
34	Infrastructure	---
35	Agriculture/forest/barren	Agriculture
36	Geoscientific Causes	i. Over saturation of unconsolidated slope material due to heavy precipitation.
37	Remedial measures	i. Removal of loose precarious boulders from the slide zone and at road level. ii. Provision of gabion wall all along the affected slopes and cleaning of drains at regular interval. iii. Sealing of ground cracks with impervious material. iv. Construction of interconnected surface drains/ proper drainage system.
38	Remarks, if any	Road subsidence and tilting of trees.

39

Photos. Sketch of Plan & section of the slide

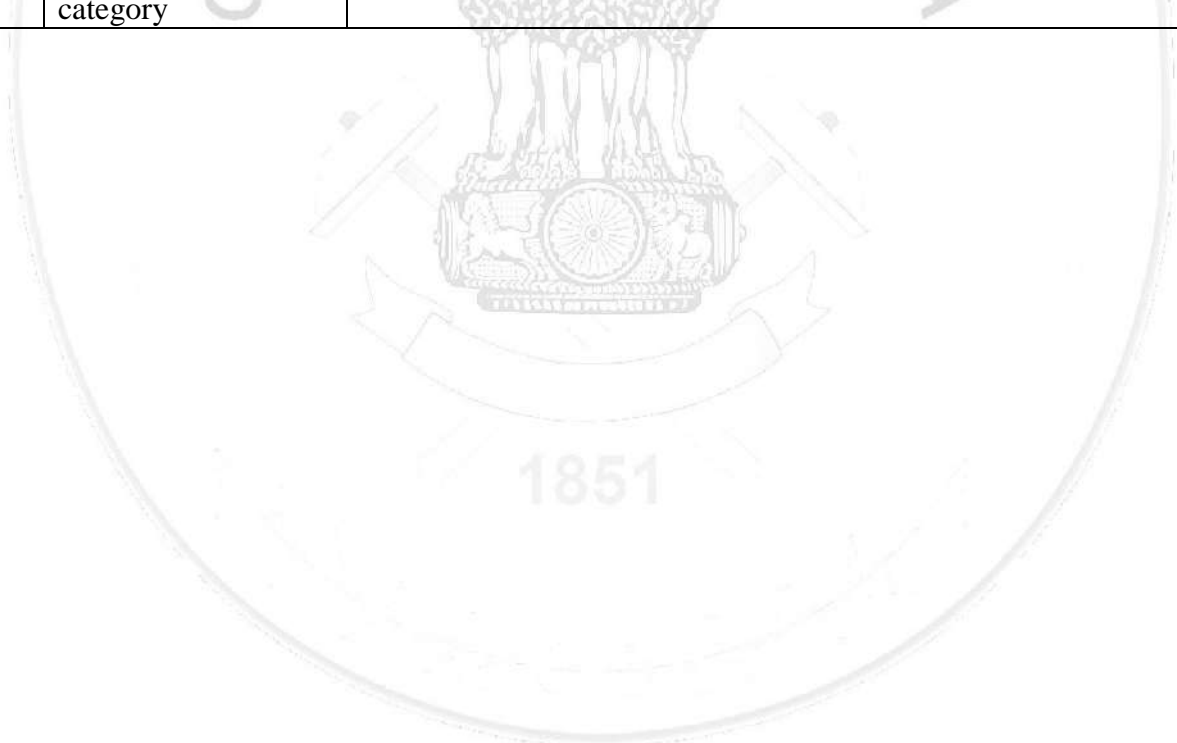

Fig: Road damaged and subsided

		
40	Summary/Abstract	<p>Fig 2: Debris slide and road subsidence.</p> <p>The evidence of slope instability is apparent through the road blockage and damaged in Chaunata village due to over saturation of unconsolidated slope material due to heavy precipitation. Removal of loose precarious boulders from the slide zone and at road level. Provision of gabion wall all along the affected slopes and cleaning of drains at regular interval, sealing of ground cracks with impervious material, and construction of interconnected surface drains/ proper drainage system has been suggested for preliminary remedial measures.</p>
41	Pdf	Attached
42	Landslide alert category	Category II

No	Field	Description
1	Slide No	HP/MAN/53A13/2023/
2	State	Himachal Pradesh
3	District	Mandi
4	Toposheet No	53A/13
5	Slide Name	Bhadyar Slide
6	NH/SH Location	Chhatter Road
7	Latitude	31.76694 N
8	Longitude	76.76750 E
9	Length	±120 m (Max. as on date of field observation)
10	Width	±80 m (Max. as on date of field observation)
11	Height	±110 m (Max. as on date of field observation)
12	Area	±9600 m ² (Max. as on date of field observation)
13	Depth	>5m
14	Volume	±49000 m ³ (Max. as on date of field observation)
15	Run out distance	±60 m (Max. as on date of field observation)
16	Type of Material	Debris
17	Type of movement	Slide
18	Rate of movement	Rapid
19	Activity	Active
20	Distribution	Retrogressive
21	Style	Multiple
22	Failure mechanism	Deep rotational failure
23	History	14 th August 2023 (Morning)
24	Geomorphology	Moderately dissected hillslope
25	Geology	Sandstone and purple shale, Dakshai Formation, Sirmur Group
26	Structure	---
27	Land use/land cover	Moderate vegetation
28	Hydrological condition	Dry (As observed during field studies)
29	Triggering factor	Rainfall
30	Death of persons	---
31	People affected	---
32	Live-stock loss	---
33	Communication	Road subsided
34	Infrastructure	
35	Agriculture/forest/barrren	Forest
36	Geoscientific Causes	i. Over saturation of unconsolidated slope material due to heavy precipitation.
37	Remedial measures	i. Removal of loose precarious boulders from the slide zone and at road level. ii. Provision of proper retaining structure with staggered drains with weep holes on hillside at road level iii. Sealing of ground cracks with impervious material. iv. Construction of interconnected surface drains/ proper drainage system.



38	Remarks, if any	
39	Photos. Sketch of Plan & section of the slide	 <p>Fig :Debris slide</p>
40	Summary/Abstract	The Debris slide comprises of big sandstone boulders (>1m) embedded in silty matrix. The slope instability aggravated during subsequent rainy seasons leading to the enlargement of the slide causing road blockage due to precarious boulders which is engulfed within the fine materials rolled down the slope. About ~100m road is affected along this slide zone.
41	Pdf	Attached
42	Landslide alert category	Category II



No	Field	Description
1	Slide No	HP/MAN/53A13/2023/
2	State	Himachal Pradesh
3	District	Mandi
4	Toposheet No	53A/13
5	Slide Name	---
6	NH/SH Location	Bhadyar Road
7	Latitude	31.76750 N
8	Longitude	76.76527 E
9	Length	±150 m (Max. as on date of field observation)
10	Width	±100 m (Max. as on date of field observation)
11	Height	±140 m (Max. as on date of field observation)
12	Area	±15000 m ² (Max. as on date of field observation)
13	Depth	>5m
14	Volume	±75000 m ³ (Max. as on date of field observation)
15	Run out distance	±100 m (Max. as on date of field observation)
16	Type of Material	Debris
17	Type of movement	Slide
18	Rate of movement	Rapid
19	Activity	Active
20	Distribution	Retrogressive
21	Style	Multiple
22	Failure mechanism	Deep rotational failure
23	History	14 th August 2023 (Morning)
24	Geomorphology	Moderately dissected hillslope
25	Geology	Sandstone and purple shale, Dakshai Formation, Sirmur Group
26	Structure	---
27	Land use/land cover	Moderate vegetation
28	Hydrological condition	Dry (As observed during field studies)
29	Triggering factor	Rainfall
30	Death of persons	---
31	People affected	---
32	Live-stock loss	---
33	Communication	Road subsided
34	Infrastructure	---
35	Agriculture/forest/barren	Forest
36	Geoscientific Causes	i. Over saturation of unconsolidated slope material due to heavy precipitation.
37	Remedial measures	i. Removal of loose precarious boulders from the slide zone and at road level. ii. Provision of proper retaining structure with staggered drains with weep holes on hillside at road level iii. Sealing of ground cracks with impervious material. iv. Construction of interconnected surface drains/ proper drainage system. v. Installation of signboards/ banners along the slope failure locations for cautioning the commuters.

38	Remarks, if any	
39	Photos. Sketch of Plan & section of the slide	 <p>Fig: Debris slide</p>
40	Summary/Abstract	<p>The slide comprises of big sandstone boulders (>1m) embedded in silty matrix. The slope instability aggravated during subsequent rainy seasons leading to the enlargement of the slide causing road blockage due to precarious boulders which is engulfed within the fine materials rolled down the slope. About ~100m road is affected along this slide zone. The slide zone is along the vicinity of Vaikrita Thrust zone. Electric pole at road level in risk zone.</p>
41	Pdf	Attached
42	Landslide alert category	Category II

No	Field	Description
1	Slide No	HP/MAN/53A13/2023/
2	State	Himachal Pradesh
3	District	Mandi
4	Toposheet No	53A/13
5	Slide Name	Brang slide
6	NH/SH Location	Brang village, Bhadyar Road
7	Latitude	31.761944 N
8	Longitude	76.768333 E
9	Length	±80 m (Max. as on date of field observation)
10	Width	±60 m (Max. as on date of field observation)
11	Height	±70 m (Max. as on date of field observation)
12	Area	±4800 m ² (Max. as on date of field observation)
13	Depth	2-5m
14	Volume	±23000 m ³ (Max. as on date of field observation)
15	Run out distance	---
16	Type of Material	Debris
17	Type of movement	Slide
18	Rate of movement	Rapid
19	Activity	Active
20	Distribution	Retrogressive, widening
21	Style	Multiple
22	Failure mechanism	Shallow rotational failure
23	History	14 th August 2023 (Morning)
24	Geomorphology	Lowly dissected hillslope
25	Geology	Sandstone and purple shale, Dakshai Formation, Sirmur Group
26	Structure	---
27	Land use/land cover	Settlement
28	Hydrological condition	Damp (As observed during field studies)
29	Triggering factor	Rainfall
30	Death of persons	---
31	People affected	Settlements located within the vicinity of the slide zone
32	Live-stock loss	---
33	Communication	Pedestrian pathway broken and damaged (±4m road subsided)
34	Infrastructure	Houses damaged and cracks along the settlement present in vicinity to the slide zone.
35	Agriculture/forest/barren	Settlements and Agriculture
36	Geoscientific Causes	i. Over saturation of unconsolidated slope material due to heavy precipitation.
37	Remedial measures	i. Removal of loose precarious boulders from the slide zone. ii. Provision of proper retaining structure with staggered drains with weep holes on hillside at road level iii. Sealing of ground cracks with impervious material. iv. Construction of interconnected surface drains/ proper drainage system. v. No further construction, loading, tampering of slope

		with heavy civil structures in/adjoining failure affected zone and in immediate vicinity of nala courses.
38	Remarks, if any	
39	Photos. Sketch of Plan & section of the slide	  <p>Fig: House damaged</p>  <p>Fig 2: Debris slide</p>
40	Summary/Abstract	Brang debris slide is a major slide zone which has affected the settlement present in vicinity to the slide zone. Pedestrian pathway were damaged (± 4 m road subsided) and settlements and agricultural land were affected. Provision of proper retaining structure with staggered drains with weep holes on hillside at road level, sealing of ground cracks with impervious material and construction of interconnected surface drains/ proper drainage system were suggested for preliminary remedial measures
41	Pdf	Attached
42	Landslide alert category	Category II

No	Field	Description
1	Slide No	HP/MAN/53A13/2023/
2	State	Himachal Pradesh
3	District	Mandi
4	Toposheet No	53A/13
5	Slide Name	Bhadyar slide
6	NH/SH Location	Bhadyar village
7	Latitude	31.76722 N
8	Longitude	76.77583 E
9	Length	±60 m (Max. as on date of field observation)
10	Width	±70 m (Max. as on date of field observation)
11	Height	±50 m (Max. as on date of field observation)
12	Area	±4200 m ² (Max. as on date of field observation)
13	Depth	2-5m
14	Volume	±21000 m ³ (Max. as on date of field observation)
15	Run out distance	---
16	Type of Material	Debris
17	Type of movement	Slide
18	Rate of movement	Rapid
19	Activity	Active
20	Distribution	Retrogressive, widening
21	Style	Multiple
22	Failure mechanism	Shallow rotational failure
23	History	14 th August 2023 (Morning)
24	Geomorphology	Lowly dissected hillslope
25	Geology	Sandstone and purple shale, Dakshai Formation, Sirmur Group
26	Structure	S ₀ // J ₁ =10°/N290°, J ₂ =340°/vertical°, J ₃ =43°/N60°
27	Land use/land cover	Settlement
28	Hydrological condition	Damp (As observed during field studies)
29	Triggering factor	Rainfall
30	Death of persons	---
31	People affected	---
32	Live-stock loss	---
33	Communication	Underconstruction road damaged.
34	Infrastructure	Houses damaged and cracks along the settlement present in vicinity to the slide zone.
35	Agriculture/forest/barren	Barren
36	Geoscientific Causes	i. Over saturation of unconsolidated slope material due to heavy precipitation.
37	Remedial measures	i. Removal of loose precarious boulders along the road bench. ii. Provision of proper retaining structure with staggered

		<p>drains with weep holes on hillside at road level</p> <p>iii. Sealing of ground cracks with impervious material.</p> <p>iv. Construction of interconnected surface drains/ proper drainage system along the settlement.</p> <p>v. No further construction, loading, tampering of slope with heavy civil structures in/adjoining failure affected zone and in immediate vicinity of <i>nala</i> courses.</p>
38	Remarks, if any	
39	Photos. Sketch of Plan & section of the slide	 <p style="text-align: center;">Fig: Debris slide</p>
40	Summary/Abstract	<p>The debris slide in Bhadyar village is due to over saturation of unconsolidated slope material due to heavy precipitation. Sealing of ground cracks with impervious material, construction of interconnected surface drains/ proper drainage system along the settlement and no further construction, loading, tampering of slope with heavy civil structures in/adjoining failure affected zone and in immediate vicinity of <i>nala</i> courses were suggested for preliminary remedial measures.</p>
41	Pdf	Attached
42	Landslide alert category	Category II

ANNEXURE VI

**42 POINT GEOPARAMETRIC DATASHEET FOR PHAGWAON VILLAGE
DIST.MANDI, HP**

No	Field	Description
1	Slide No	HP/MAN/53A15/2023/
2	State	Himachal Pradesh
3	District	Mandi
4	Toposheet No	53A/15
5	Slide Name	Phagwaon slide
6	NH/SH Location	Phagwaon village, Kaleru road
7	Latitude	31.480833 N
8	Longitude	76.963333 E
9	Length	±70 m (Max. as on date of field observation)
10	Width	±100 m (Max. as on date of field observation)
11	Height	±60 m (Max. as on date of field observation)
12	Area	±7000 m ² (Max. as on date of field observation)
13	Depth	2-5m
14	Volume	±35000 m ³ (Max. as on date of field observation)
15	Run out distance	---
16	Type of Material	Slope debris
17	Type of movement	Slide and subsidence
18	Rate of movement	Slow
19	Activity	Active
20	Distribution	Widening
21	Style	Multiple
22	Failure mechanism	Shallow Rotational failure
23	History	Initiated on 14 th August 2023 (Morning)
24	Geomorphology	Lowly dissected hillslope
25	Geology	Schist and quartzite, Khokan Formation, Kulu Group
26	Structure	S ₀ // J ₁ =48°/N240° Vaikrita Thrust towards Northeastern side of present incidence. [Source: Geol. Map of T/S No. 53A/15, Geodata Div, GSI Chandigarh]
27	Land use/land cover	Settlement, Agriculture and open shrubs
28	Hydrological condition	Damp (As on date of field observation)
29	Triggering factor	Rainfall
30	Death of persons	---
31	People affected	---
32	Live-stock loss	---
33	Communication	Road damaged.
34	Infrastructure	Three buildings around the village damaged.
35	Agriculture/forest /barren	---

36	Geoscientific Causes	Over saturation of unconsolidated slope material due to heavy precipitation and poor drainage system.
37	Remedial measures	<ul style="list-style-type: none"> i. Removal of loose and precarious boulders along the road bench to enhance safety. ii. Provision of sturdy retaining structures with staggered drains and weep holes at the hillside road level to prevent soil erosion. iii. Sealing of ground cracks with impervious material to minimize water infiltration and further damage. iv. Installation of Rain gauge and monitoring devices to constantly track ground movements, slope stability and soil moisture levels for timely intervention and hazard mitigation. v. Implement early warning systems to promptly alert residents and authorities about potential landslide events, enabling swift evacuation and response efforts. vi. Improve drainage system to efficiently manage surface water runoff, mitigating the risk of slope destabilization. Design proper drainage channels to help direct water away from vulnerable areas. vii. Conduct community awareness programs to educate residents about the geological risks associated with living near a thrust zone. Promote disaster preparedness, conduct drills, and provide information on evacuation procedure.
38	Remarks, if any	Crown of the slide not observed during field studies but subsidence of road and ground cracks observed at different locations (30-50 cm width, 50 cm depth and 2.5m length)
39	Photos. Sketch of Plan & section of the slide	

		
40	Summary/Abstract	The preliminary assessment around the affected sites around revealed varied unfavourable geological (highly weathered rocks due to its proximity to two thrust zones) and hydrogeological conditions. The most significant causative factor for the triggering and development of landslide is the continuous heavy rainfall leading to saturation of thick slope wash debris material/highly weathered rock and lack of adequate drainage system.
41	Pdf	Attached
42	Landslide alert category	Category III

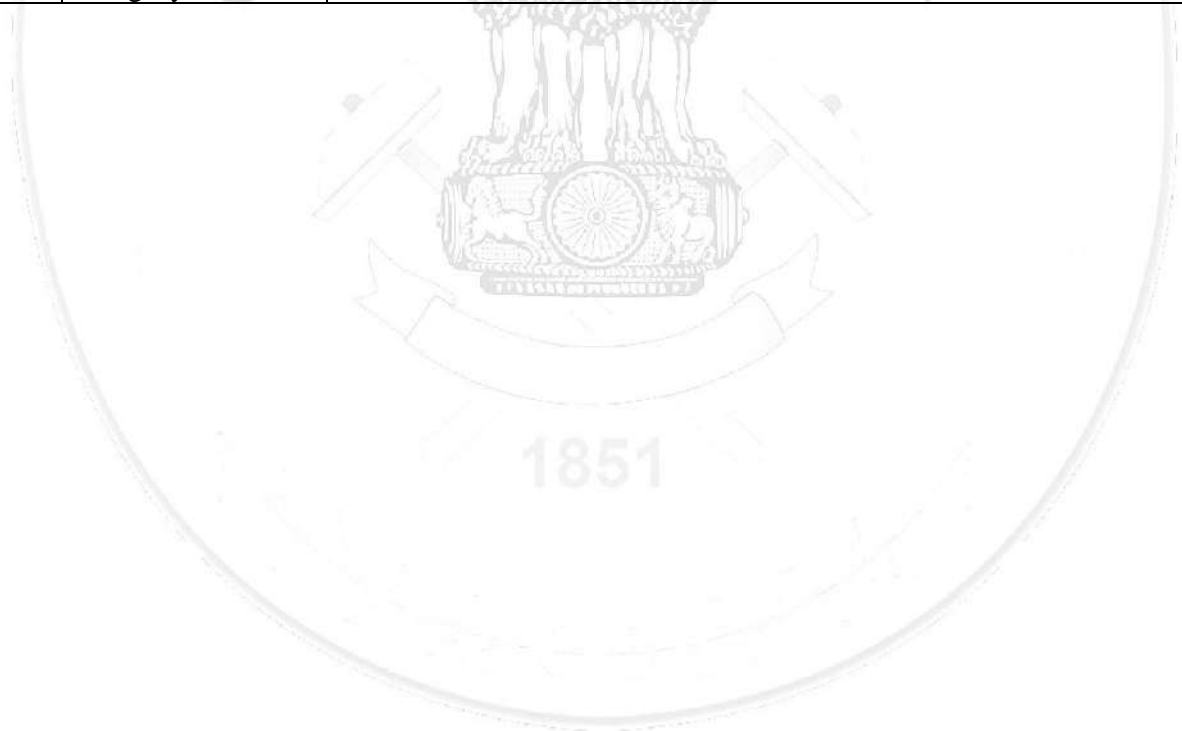

No	Field	Description
1	Slide No	HP/MAN/53A15/2023/
2	State	Himachal Pradesh
3	District	Mandi
4	Toposheet No	53A/15
5	Slide Name	Doldhar slide
6	NH/SH Location	Doldhar village
7	Latitude	31.466111 N
8	Longitude	76.944166 E
9	Length	±60 m (Max. as on date of field observation)
10	Width	±70 m (Max. as on date of field observation)
11	Height	±50 m (Max. as on date of field observation)
12	Area	±4200 m ² (Max. as on date of field observation)
13	Depth	2-5m
14	Volume	±16800 m ³ (Max. as on date of field observation)
15	Run out distance	---
16	Type of Material	Debris
17	Type of movement	Slide and subsidence
18	Rate of movement	Slow
19	Activity	Active
20	Distribution	Retrogressive, widening
21	Style	Multiple
22	Failure mechanism	Shallow rotational failure
23	History	Initiated on 14 th August 2023 (Morning)
24	Geomorphology	Lowly dissected hillslope
25	Geology	Chlorite schist and quartzite, Khokan Formation, Kulu Group
26	Structure	S ₀ // J ₁ =10°/N240°, J ₂ =75°/N70°, J ₃ =78°/N160°, J ₄ =65°/N20°
27	Land use/land cover	Settlement, Agriculture and open shrubs
28	Hydrological condition	Damp (As observed during field studies)
29	Triggering factor	Rainfall
30	Death of persons	---
31	People affected	---
32	Live-stock loss	---
33	Communication	Road damaged
34	Infrastructure	3 houses damaged
35	Agriculture/forest/b arren	---
36	Geoscientific Causes	Over saturation of unconsolidated slope material due to heavy precipitation and poor drainage system.

37	Remedial measures	<ul style="list-style-type: none"> i. Removal of loose and precarious boulders along the road bench to enhance safety. ii. Provision of sturdy retaining structures with staggered drains and weep holes at the hillside road level to prevent soil erosion. iii. Sealing of ground cracks with impervious material to minimize water infiltration and further damage. iv. Installation of rain gauge and monitoring devices to constantly track ground movements, slope stability and soil moisture levels for timely intervention and hazard mitigation. v. Improve drainage system to efficiently manage surface water runoff, mitigating the risk of slope destabilization. Design proper drainage channels to help direct water away from vulnerable areas.
38	Remarks, if any	---
39	Photos. Sketch of Plan & section of the slide	
40	Summary/Abstract	<p>The preliminary assessment around the affected sites around revealed varied unfavourable geological (highly weathered rocks due to its proximity to two thrust zones) and hydrogeological conditions. The most significant causative factor for the triggering and development of landslide is the continuous heavy rainfall leading to saturation of thick slope wash debris material/highly weathered rock and lack of adequate drainage system.</p>
41	Pdf	Attached
42	Landslide alert category	Category II

ANNEXURE II

**42 POINT GEOPARAMETRIC DATASHEET FOR TARNA HILL
DIST.MANDI, HP**



No	Field	Description
1	Slide No	HP/MAN/53A14/2023/
2	State	Himachal Pradesh
3	District	Mandi
4	Toposheet No	53A/14
5	Slide Name	Tarna Hill debris slide
6	NH/SH Location	Near Hotel Koyal, Mangwai Road
7	Latitude	31.705220 N
8	Longitude	76.933442 E
9	Length	±80 m (Max. as on date of field observation)
10	Width	±120 m (Max. as on date of field observation)
11	Height	±50 m (Max. as on date of field observation)
12	Area	±4000 m ² (Max. as on date of field observation)
13	Depth	>5m
14	Volume	±20000 m ³ (Max. as on date of field observation)
15	Run out distance	---
16	Type of Material	Debris
17	Type of movement	Slide
18	Rate of movement	Rapid
19	Activity	Active
20	Distribution	Enlarging
21	Style	Single
22	Failure mechanism	Deep rotational failure
23	History	Initiated on 14 th August 2023 (Morning)
24	Geomorphology	Lowly dissected hill
25	Geology	Basalt and quartz arenite, Mandi volcanics, Sundernagar Group.
26	Structure	S ₀ // J ₁ =30°/N100°, J ₂ =50°/N260°, J ₃ =85°/N260° The slide is situated in close proximity to Kullu thrust and Mandi-Sundernagar Thrust.
27	Land use/land cover	Settlement
28	Hydrological condition	Damp
29	Triggering factor	Rainfall
30	Death of persons	---
31	People affected	Settlement on the crown portion and right and left flank of the incidence zone.
32	Live-stock loss	---
33	Communication	Mangwai road affected, local pavement on the crown portion destroyed
34	Infrastructure	Electric pole on the crown portion at risk.
35	Agriculture/forest /barren	---

36	Geoscientific Causes	The most important causative factor for the triggering and development of landslide is the continuous heavy rainfall and oversaturation of water within the fragile and loose material of slope forming material leading to slope failure.
37	Remedial measures	<ol style="list-style-type: none"> i. Sealing of ground cracks wherever possible by impervious material (impervious clay, tar etc.) to restrict water infiltration. Area above the crown of landslide needs to be monitored for development of any new ground cracks. The cracks must be sealed either by filling them with clay or other impervious fill like Bentonite to reduce further permeability to ensure surface water does not pond in the area. ii. Several loose boulders present on the slope area between crown and Mangwai road corridor can be removed manually and modified slope in to terraces for multi levels using adequate retaining wall structure with a provision of weep holes. iii. Construction of proper lined drainage at the crown portion to arrest maximum infiltration of water surface water into distressed zone. iv. Ensuring construction of the Civil Structures strictly following building BIS codes.
38	Remarks, if any	---
39	Photos. Sketch of Plan & section of the slide	 <p style="text-align: center;">Fig 1: Debris slide near Koyal Hotel.</p>
40	Summary/Abstract	<p>Since the first week of August 2023, Tarna Hill has shown signs of structural deterioration due to continuous heavy rainfall in July 2023. The situation worsened following the relentless rains on 12th and 13th August, culminating in a slide on 14th August 2023. This event resulted in the collapse of one building and significant damage to several others, prompting residents to evacuate. Fortunately, prompt action by district authorities averted casualties. It is a debris slide triggered due to oversaturation of debris material due to heavy rainfall. This slide obliterated pathways, drainage systems and disrupted essential services like electricity. Various diagnostic signs revealed the slide's enlarging nature, presenting an imminent threat to nearby structures. The crown portion exhibited tension cracks and the presence of natural</p>

		springs. The areas geology and its proximity to thrusts and high grade of weathering indices contributed to its susceptibility to landslides. The assessment emphasizes the importance of proper construction practices and effective mitigation strategies to address the looming threat of landslides in the area.
41	Pdf	Attached
42	Landslide alert category	Category I

**42 POINT GEOPARAMETRIC DATASHEET FOR KANGNIDHAR LANDSLIDE
DIST.MANDI, HP**

No	Field	Description
1	Slide No	HP/MAN/53A14/2023/
2	State	Himachal Pradesh
3	District	Mandi
4	Toposheet No	53A/14
5	Slide Name	Kangnidhar debris slide
6	NH/SH Location	Mandi Rewalsar Highway
7	Latitude	31.705220 N
8	Longitude	76.933442 E
9	Length	±80 m (Max. as on date of field observation)
10	Width	±80 m (Max. as on date of field observation)
11	Height	±30 m (Max. as on date of field observation)
12	Area	±4000 m ² (Max. as on date of field observation)
13	Depth	>5m
14	Volume	±20000 m ³ (Max. as on date of field observation)
15	Run out distance	---
16	Type of Material	Debris
17	Type of movement	Slide
18	Rate of movement	Rapid
19	Activity	Active
20	Distribution	Enlarging
21	Style	Single
22	Failure mechanism	Deep rotational failure
23	History	Initiated on 14 th August 2023 (Morning)
24	Geomorphology	Lowly dissected hill
25	Geology	Basalt and quartz arenite, Mandi volcanics, Sundernagar Group.
26	Structure	S ₀ // J ₁ =30°/N100°, J ₂ =50°/N260°, J ₃ =85°/N260° The slide is situated in close proximity to Kullu thrust and Mandi-Sundernagar Thrust.
27	Land use/land cover	Settlement
28	Hydrological condition	Damp
29	Triggering factor	Rainfall
30	Death of persons	---
31	People affected	Settlement on the crown portion and right and left flank of the incidence zone.
32	Live-stock loss	---
33	Communication	Road ,pavement on the crown portion affected
34	Infrastructure	Electric pole on the crown portion at risk.
35	Agriculture/forest /barren	---
36	Geoscientific Causes	The most important causative factor for the triggering and development of landslide is the continuous heavy rainfall and

		oversaturation of water within the fragile and loose material of slope forming material leading to slope failure.
37	Remedial measures	<ul style="list-style-type: none"> i. Several loose boulders present on the slope area between crown and Mangwai road corridor can be removed manually and modified slope in to terraces for multi levels using adequate retaining wall structure with a provision of weep holes. ii. Construction of proper lined drainage at the crown portion to arrest maximum infiltration of water surface water into distressed zone. iii. Ensuring construction of the Civil Structures strictly following building BIS codes.
38	Remarks, if any	---
39	Photos. Sketch of Plan & section of the slide	 <p>Figure 1 Morphometry of the Kanganidhar Landslide.</p>  <p>Figure 2 The active scarp characterized by steep slope exposing loose debris material</p>
41	Pdf	Attached
42	Landslide alert category	Category I

Content

	Page No.
1. INTRODUCTION	1
2. SCOPE OF WORK	1
3. LOCATION	1
4. CLIMATE AND RAINFALL	2
5. GEOMORPHOLOGY	2
6. SAMPLING AND SAMPLE IDENTIFICATION	3
7. LABORATORY TESTS CONDUCTED	3
8. SOIL PROPERTIES AND CLASSIFICATION	4

1. INTRODUCTION

The purpose of this study is to determine the properties of soil samples sent by Additional District Magistrate Cum -CEO, DDMA, Mandi, District Mandi H.P. via office letter No. DC/MAN/DDMA/DEOC-20/2021-4329 Mandi dated 16th October, 2023. The samples were provided to the Department of Civil Engineering, National Institute of Technology Hamirpur for determination of index and engineering properties of soil samples. The report's scope is limited to determining the index and engineering properties of soil samples provided through laboratory tests.

2. SCOPE OF WORK

Conducting laboratory tests on the soil samples provided and thereby determining various index and engineering properties and summarizing the detail of soil classification. This report provides the following soil properties as desired by client:

1. Unit weight (Dry)
2. Saturated Unit weight
3. Cohesion
4. Angle of Internal friction
5. Modulus of elasticity
6. Poisson's ratio
7. Grain size analysis by pipette method
8. Atterberg limits
9. Natural density test
10. Natural moisture content
11. Strength parameters by Direct shear test
12. Specific gravity
13. Permeability
14. Free swell index
15. UCS (Unconfined Compressive Strength)

3. LOCATION

Mandi is a major city and a municipal corporation in Mandi District in the Indian state of Himachal Pradesh. It is situated 145 kilometres north of state capital, Shimla in the north-west Himalayas at an average altitude of 880 m. Mandi is connected to the Pathankot through National Highway 20 and to Manali and Chandigarh through National Highway 21. Mandi is



approximately 184.6 km from Chandigarh, the nearest major city, and 440.9 km from New Delhi, the national capital. It serves as the headquarters of Mandi District and Zonal Headquarters of central zone including districts namely Kullu, Bilaspur, and Hamirpur. Mandi is built on the banks of the Beas River, at the confluence of the Suketi Khad stream. Sikandar Dhar, Ghugar Dhar and Dhar Kot are some of the prominent hills and mountains found near the city. Mandi is located in 31°72'N latitude and 76°92'E longitude. It has an average elevation of 764 metres from mean sea level.

4. CLIMATE AND RAINFALL

The climate of Mandi is composite having hot summers and cold winters. Mandi generally experiences rainfalls during end of summer season. Mandi city falls in the lower most climatic zone of the Himalayas. Temperatures typically range from 6.7 to 39.6 °C over the course of a year. The average temperature during summer is between 18.9 and 39.6 °C and between 6.7 and 26.2 °C in winter. Monthly precipitation varies between 25.4 millimetres in November to 228.6 millimetres in August. It is typically around 58.3 millimetres per month during winter and spring and around 101.6 millimetres in June as the monsoon approaches. The average total annual precipitation is 832 millimetres.

5. GEOMORPHOLOGY

The district of Mandi has two types of soil are mainly observed in the district viz, Sub Mountainous soil occurring in Seraj and Karsog blocks and mountainous soil occurring in remaining eight blocks of the district. The rock formations occupying the district range from Precambrian to Quaternary period. There is a complex mosaic of mountain ranges, hills, and deep valleys. It is largely a hilly district. From west to east and south to north, there is a general rise in height. The master slope is oriented south-west. The district has been subdivided into four Geo-morphological zones: fluvial terrain, fluvial-glacial terrain, Alpines / meadows, and Rocky terrain. The different types of soils found in the district can be divided into three categories: Type-I, Type-II, and Type-III. In nature, Type-I soil is coarse loamy and mixed. Granite's, highly metamorphosed gneiss's, and schist's make up the soil, which can be found on moderately sloping to steep terrain. These soils are well-drained and permeability is moderate. Fine loamy, mixed, and cold soils are found in Type II. They arose from granite-gneiss and mica schist parent material on steep to extremely steep slopes at altitudes of around 3359.00 meters. Shikari Devi Temple, Janjehli, Rocky II, and Scree series are examples of Type III soil.

6. SAMPLING AND SAMPLE IDENTIFICATION

Total five nos. of undisturbed soil samples were supplied by office of Additional District Magistrate Cum -CEO, DDMA, Mandi, District Mandi H.P to Department of Civil Engineering, National Institute of Technology Hamirpur for determination of index and engineering properties. Details and codification of the samples have been given in Table 1:

Table 1 Location and Codification of Samples

Location	Number of samples	Sample number
Tarna Hill	03	M/T/TOE/1
		M/T/BE/1
		M/T/C3
Kangnidhar Hill	02	M/KA/TOE/1
		M/KA/C/2

7. LABORATORY TESTS CONDUCTED

Table 2 shows the properties of soil which have to be determined as per client's demand. The various laboratory tests were performed on all the five soil samples. All the tests have been performed as per Indian Standard codes and various properties of soil as have been determined.

Table 2 Properties of soil

Sr. No.	Soil Property
1	Unit weight (Dry)
2	Saturated Unit weight
3	Cohesion
4	Angle of Internal friction
5	Modulus of elasticity
6	Poisson's ratio
7	Grain size analysis by pipette method
8	Atterberg limits
9	Natural density test
10	Natural moisture content
11	Strength parameters by Direct shear test
12	Specific gravity
13	Permeability
14	Free swell index
15	UCS (Unconfined Compressive Strength)

8. SOIL PROPERTIES AND CLASSIFICATION

Table 3 shows the properties and soil classification of undisturbed soil samples of Tarna Hill, Land Sinking location and Table 4 depicts the properties and soil classification of undisturbed soil samples of Kangnidhar Land Sinking location. Figures 1 and 2 show grain size distribution (GSD) curves for all five samples of Tarna Hill, Land Sinking location and Kangnidhar Land Sinking location, respectively.

Table 3 Properties of undisturbed soil samples (Tarna Hill, Land Sinking)

Sr. No	Property	Unit	Sample location		
			M/T/TOE/1	M/T/BE/2	M/T/C/3
1	Dry unit weight	kN/m ³	16.36	15.82	16.68
2	Saturated unit weight	kN/m ³	18.23	16.90	17.87
3	Cohesion (c)	kPa	8.1	6.66	6.6
4	Angle of Internal Friction	Deg.	30.0	31.0	29.7
5	Modulus of elasticity	kPa	9600	10710	7998
6	Poisson Ratio	Unitless	0.3	0.3	0.3
7.	Grain Size Analysis (GSD curves are shown in Figs 1a, 1b and 1c)				
	D ₆₀	mm	1.640	1.690	1.864
	D ₃₀	mm	0.350	0.463	0.557
	D ₁₀	mm	0.078	0.105	0.178
	C _u	Unit less	20.84	16.11	10.49
	C _c	Unit less	0.950	1.16	0.935
	Soil Classification		SP-SM	SW-SC	SP
8.	Atterberg Limit Tests				
	Liquid limit	(%)	32.5	27.4	28.8
	Plastic limit	(%)	23.8	21.6	20.4
	Plasticity index	(%)	8.7	5.8	8.4
9.	Natural Density	g/cc	1.86	1.72	1.82
10.	Natural water content	(%)	11.42	6.86	7.08
11.	Direct Shear Test	Results have been given in sr. no 3 & 4			
12.	Specific Gravity	Unit less	2.48	2.55	2.62
13.	Permeability	cm/s	3.9x10 ⁻⁴	2.6x10 ⁻⁴	2.8x10 ⁻⁴
14.	Free Swell Index	(%)	0.012	0.037	0.011
15.	UCS (Unconfined Compressive Strength)	kPa	24.00	23.39	23.48



Table 4 Properties of undisturbed soil samples (Kangnidhar Land Sinking)

Sr. No	Property	Unit	Sample location	
			M/KA/TOE/1	M/KA/C/2
1	Dry unit weight	kN/m ³	15.00	16.32
2	Saturated unit weight	kN/m ³	16.12	17.60
3	Cohesion (c)	kPa	4.9	6.2
4	Angle of Internal Friction	Deg.	30.0	31.0
5	Modulus of elasticity	kPa	9600	10710
6	Poisson Ratio	Unitless	0.3	0.3
7	Grain Size Analysis ((GSD curves are shown in Figs 2a and 2b)			
	D ₆₀	mm	1.411	1.053
	D ₃₀	mm	0.379	0.295
	D ₁₀	mm	0.102	0.115
	C _u	Unit less	13.83	9.16
	C _c	Unit less	1.01	0.72
	Soil Classification		SW-SC	SP-SC
8	Atterberg Limit Tests			
	Liquid limit	(%)	27.9	31.1
	Plastic limit	(%)	20.8	22.2
	Plasticity index	(%)	7.1	8.9
9.	Natural Density	g/cc	1.64	1.79
10.	Natural water content	(%)	7.44	7.79
11	Direct Shear Test	Results have been given in sr. no 3 & 4		
12.	Specific Gravity	Unit less	2.60	2.49
13.	Permeability	cm/s	2.5x10 ⁻³	2.6x10 ⁻³
14.	Free Swell Index	(%)	0.025	0.00
15.	UCS (Unconfined Compressive Strength)	kPa	17.25	22.33



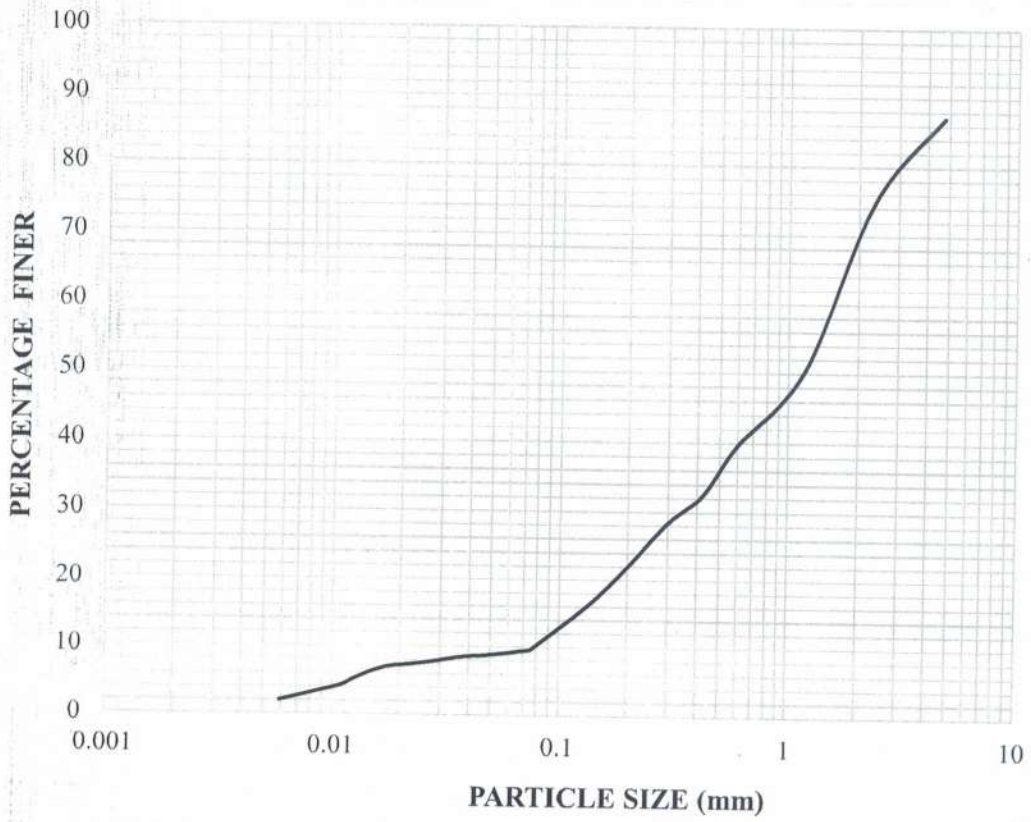

Fig. 1(a) Grain size distribution of soil samples M/T/TOE/1 (Tarna Hill, Land Sinking)

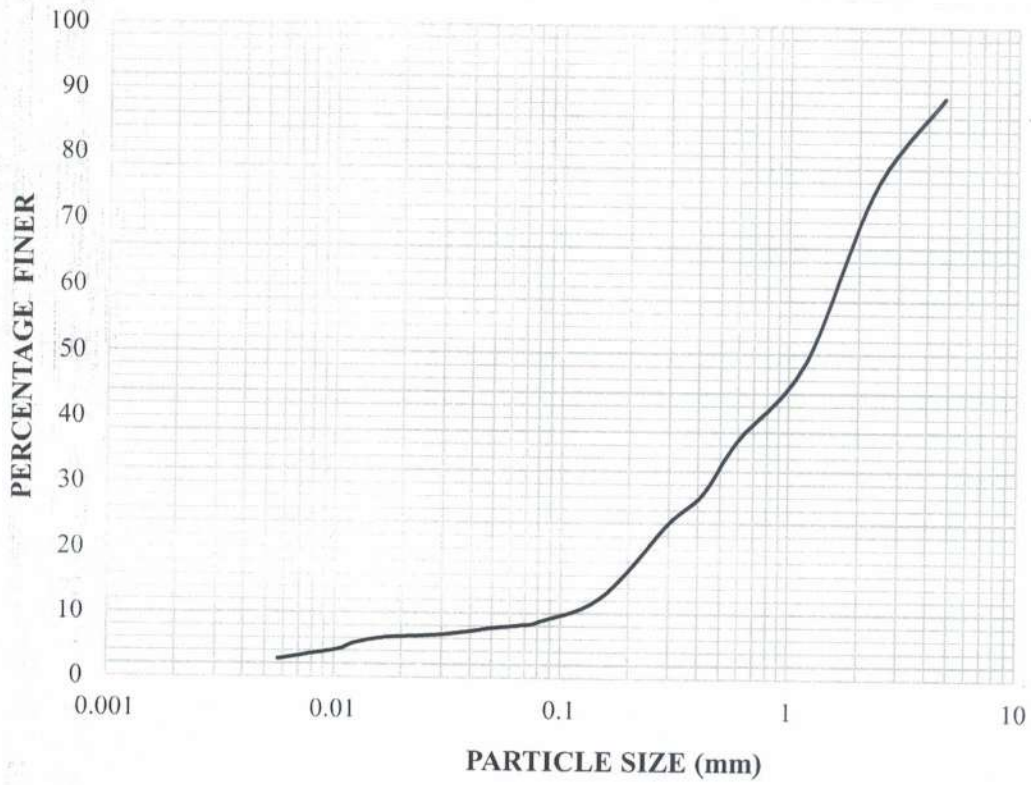

Fig. 1(b) Grain size distribution of soil samples M/T/BE/2 (Tarna Hill, Land Sinking)

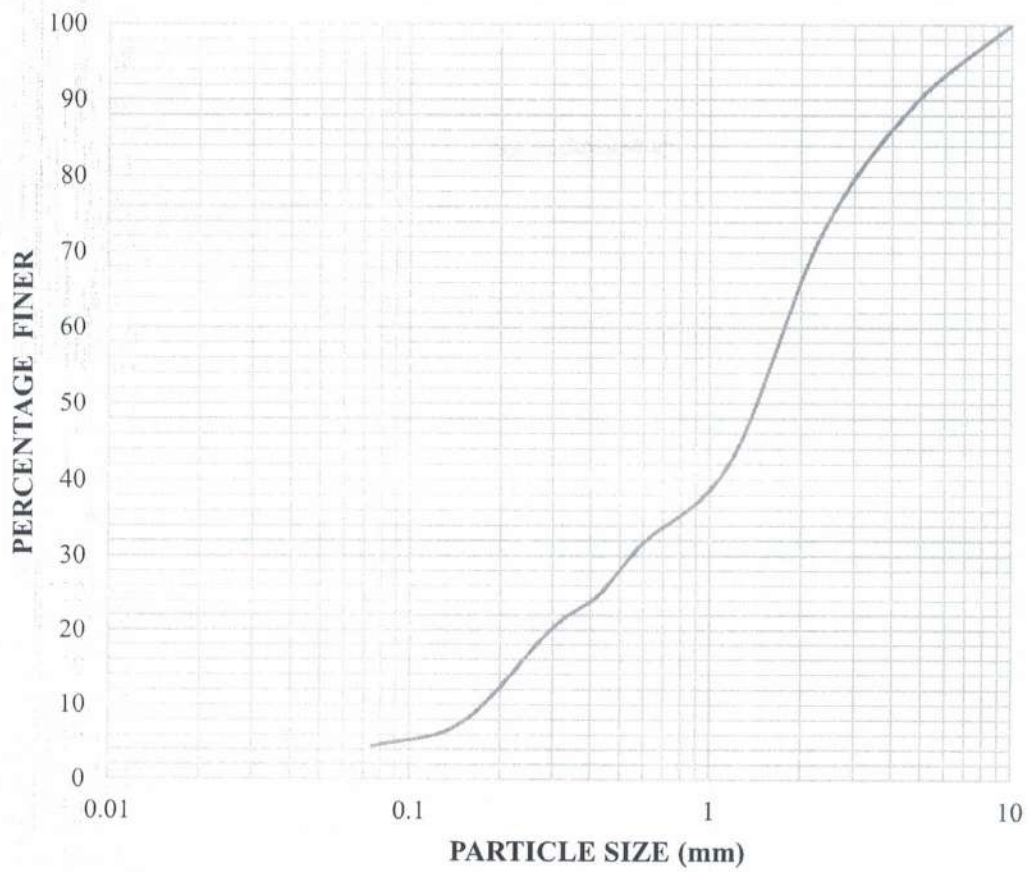

Fig. 1(c) Grain size distribution of soil samples M/T/C/3 (Tarna Hill, Land Sinking)

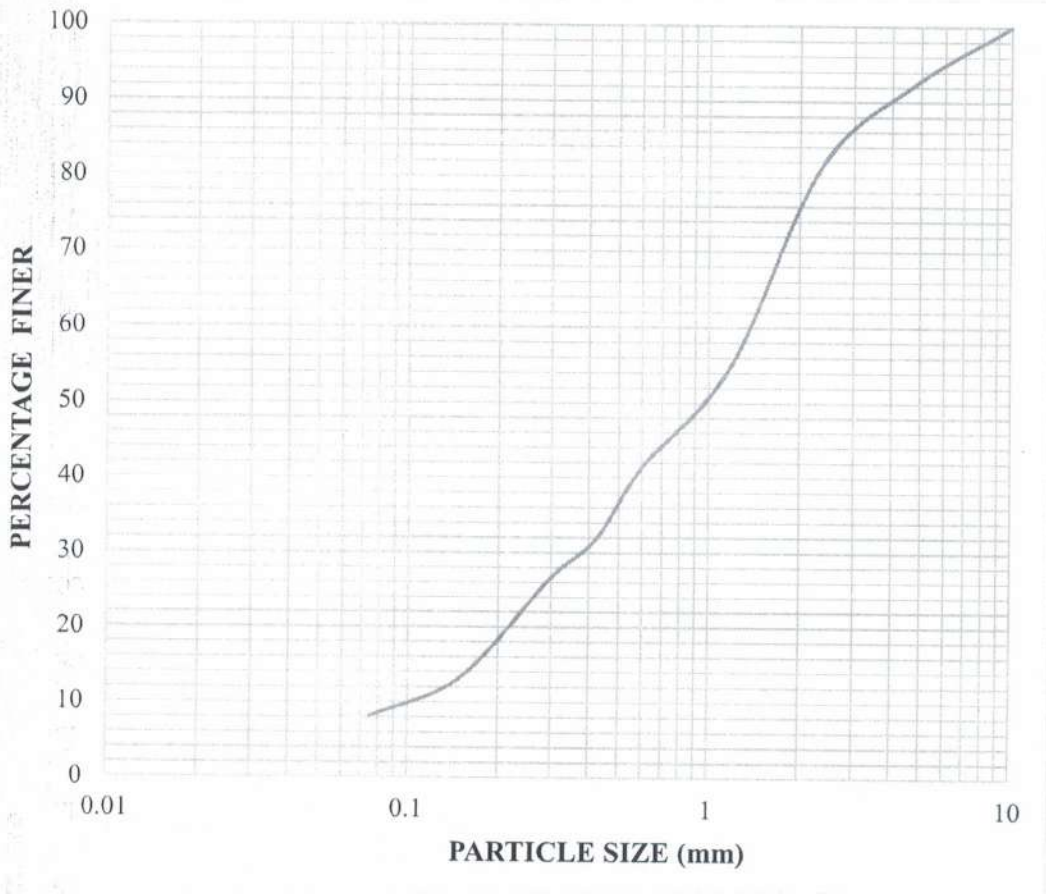

Fig. 2(a) Grain size distribution of soil samples M/KA/TOE/1 (Kangnidhar Land Sinking)

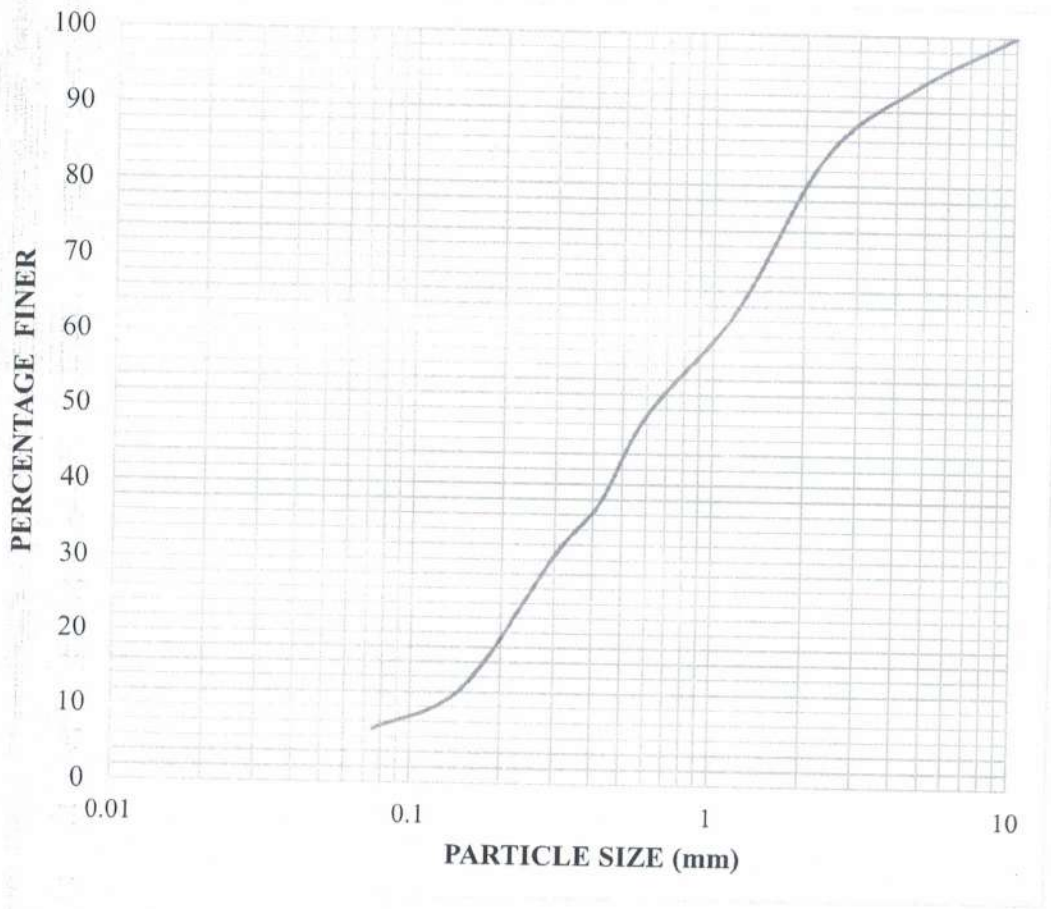

Fig. 2(b) Grain size distribution of soil samples M/KA/C/2 (Kangnidhar Land Sinking)

The results reported in this report are solely valid for the samples submitted by the client to the Department of Civil Engineering, National Institute of Technology Hamirpur (H.P.)



Dr Manendra Singh
Assistant Professor
Department of Civil Engineering
NIT Hamirpur



Dr R. S. Banshtu
Associate Professor
Department of Civil Engineering
NIT Hamirpur

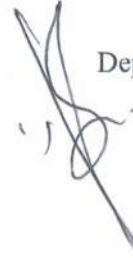



राष्ट्रीय प्रौद्योगिकी संस्थान हमीरपुर

हमीरपुर (हि.प्र.) – 177 005 (भारत)

[भारत सरकार शिक्षा मंत्रालय के तहत एक राष्ट्रीय महत्व का संस्थान]

NATIONAL INSTITUTE OF TECHNOLOGY HAMIRPUR

HAMIRPUR (H.P.) - 177 005 (INDIA)

[An Institute of National Importance under Ministry of Education (Shiksha Mantralaya)]

**DETERMINATION OF SOIL
PROPERTIES
(Tarna Hill & Kangnidhar)**

**CLIENT: Deputy Commissioner Mandi
District Mandi H.P.**



SUBMITTED BY:

**Department of Civil Engineering
National Institute of Technology Hamirpur
Hamirpur-177005, Himachal Pradesh**

Content

	Page No.
1. INTRODUCTION	1
2. SCOPE OF WORK	1
3. LOCATION	1
4. CLIMATE AND RAINFALL	2
5. GEOMORPHOLOGY	2
6. SAMPLING AND SAMPLE IDENTIFICATION	3
7. LABORATORY TESTS CONDUCTED	3
8. SOIL PROPERTIES AND CLASSIFICATION	4

1. INTRODUCTION

The purpose of this study is to determine the properties of soil samples sent by Additional District Magistrate Cum -CEO, DDMA, Mandi, District Mandi H.P. via office letter No. DC/MAN/DDMA/DEOC-20/2021-4329 Mandi dated 16th October, 2023. The samples were provided to the Department of Civil Engineering, National Institute of Technology Hamirpur for determination of index and engineering properties of soil samples. The report's scope is limited to determining the index and engineering properties of soil samples provided through laboratory tests.

2. SCOPE OF WORK

Conducting laboratory tests on the soil samples provided and thereby determining various index and engineering properties and summarizing the detail of soil classification. This report provides the following soil properties as desired by client:

1. Unit weight (Dry)
2. Saturated Unit weight
3. Cohesion
4. Angle of Internal friction
5. Modulus of elasticity
6. Poisson's ratio
7. Grain size analysis by pipette method
8. Atterberg limits
9. Natural density test
10. Natural moisture content
11. Strength parameters by Direct shear test
12. Specific gravity
13. Permeability
14. Free swell index
15. UCS (Unconfined Compressive Strength)

3. LOCATION

Mandi is a major city and a municipal corporation in Mandi District in the Indian state of Himachal Pradesh. It is situated 145 kilometres north of state capital, Shimla in the north-west Himalayas at an average altitude of 880 m. Mandi is connected to the Pathankot through National Highway 20 and to Manali and Chandigarh through National Highway 21. Mandi is



approximately 184.6 km from Chandigarh, the nearest major city, and 440.9 km from New Delhi, the national capital. It serves as the headquarters of Mandi District and Zonal Headquarters of central zone including districts namely Kullu, Bilaspur, and Hamirpur. Mandi is built on the banks of the Beas River, at the confluence of the Suketi Khad stream. Sikandar Dhar, Ghugar Dhar and Dhar Kot are some of the prominent hills and mountains found near the city. Mandi is located in 31°72'N latitude and 76°92'E longitude. It has an average elevation of 764 metres from mean sea level.

4. CLIMATE AND RAINFALL

The climate of Mandi is composite having hot summers and cold winters. Mandi generally experiences rainfalls during end of summer season. Mandi city falls in the lower most climatic zone of the Himalayas. Temperatures typically range from 6.7 to 39.6 °C over the course of a year. The average temperature during summer is between 18.9 and 39.6 °C and between 6.7 and 26.2 °C in winter. Monthly precipitation varies between 25.4 millimetres in November to 228.6 millimetres in August. It is typically around 58.3 millimetres per month during winter and spring and around 101.6 millimetres in June as the monsoon approaches. The average total annual precipitation is 832 millimetres.

5. GEOMORPHOLOGY

The district of Mandi has two types of soil are mainly observed in the district viz, Sub Mountainous soil occurring in Seraj and Karsog blocks and mountainous soil occurring in remaining eight blocks of the district. The rock formations occupying the district range from Precambrian to Quaternary period. There is a complex mosaic of mountain ranges, hills, and deep valleys. It is largely a hilly district. From west to east and south to north, there is a general rise in height. The master slope is oriented south-west. The district has been subdivided into four Geo-morphological zones: fluvial terrain, fluvial-glacial terrain, Alpines / meadows, and Rocky terrain. The different types of soils found in the district can be divided into three categories: Type-I, Type-II, and Type-III. In nature, Type-I soil is coarse loamy and mixed. Granite's, highly metamorphosed gneiss's, and schist's make up the soil, which can be found on moderately sloping to steep terrain. These soils are well-drained and permeability is moderate. Fine loamy, mixed, and cold soils are found in Type II. They arose from granite-gneiss and mica schist parent material on steep to extremely steep slopes at altitudes of around 3359.00 meters. Shikari Devi Temple, Janjehli, Rocky II, and Scree series are examples of Type III soil.



6. SAMPLING AND SAMPLE IDENTIFICATION

Total five nos. of undisturbed soil samples were supplied by office of Additional District Magistrate Cum -CEO, DDMA, Mandi, District Mandi H.P to Department of Civil Engineering, National Institute of Technology Hamirpur for determination of index and engineering properties. Details and codification of the samples have been given in Table 1:

Table 1 Location and Codification of Samples

Location	Number of samples	Sample number
Tarna Hill	03	M/T/TOE/1
		M/T/BE/1
		M/T/C3
Kangnidhar Hill	02	M/KA/TOE/1
		M/KA/C/2

7. LABORATORY TESTS CONDUCTED

Table 2 shows the properties of soil which have to be determined as per client's demand. The various laboratory tests were performed on all the five soil samples. All the tests have been performed as per Indian Standard codes and various properties of soil as have been determined.

Table 2 Properties of soil

Sr. No.	Soil Property
1	Unit weight (Dry)
2	Saturated Unit weight
3	Cohesion
4	Angle of Internal friction
5	Modulus of elasticity
6	Poisson's ratio
7	Grain size analysis by pipette method
8	Atterberg limits
9	Natural density test
10	Natural moisture content
11	Strength parameters by Direct shear test
12	Specific gravity
13	Permeability
14	Free swell index
15	UCS (Unconfined Compressive Strength)

8. SOIL PROPERTIES AND CLASSIFICATION

Table 3 shows the properties and soil classification of undisturbed soil samples of Tarna Hill, Land Sinking location and Table 4 depicts the properties and soil classification of undisturbed soil samples of Kangnidhar Land Sinking location. Figures 1 and 2 show grain size distribution (GSD) curves for all five samples of Tarna Hill, Land Sinking location and Kangnidhar Land Sinking location, respectively.

Table 3 Properties of undisturbed soil samples (Tarna Hill, Land Sinking)

Sr. No	Property	Unit	Sample location		
			M/T/TOE/1	M/T/BE/2	M/T/C/3
1	Dry unit weight	kN/m ³	16.36	15.82	16.68
2	Saturated unit weight	kN/m ³	18.23	16.90	17.87
3	Cohesion (c)	kPa	8.1	6.66	6.6
4	Angle of Internal Friction	Deg.	30.0	31.0	29.7
5	Modulus of elasticity	kPa	9600	10710	7998
6	Poisson Ratio	Unitless	0.3	0.3	0.3
7.	Grain Size Analysis (GSD curves are shown in Figs 1a, 1b and 1c)				
	D ₆₀	mm	1.640	1.690	1.864
	D ₃₀	mm	0.350	0.463	0.557
	D ₁₀	mm	0.078	0.105	0.178
	C _u	Unit less	20.84	16.11	10.49
	C _c	Unit less	0.950	1.16	0.935
	Soil Classification		SP-SM	SW-SC	SP
8.	Atterberg Limit Tests				
	Liquid limit	(%)	32.5	27.4	28.8
	Plastic limit	(%)	23.8	21.6	20.4
	Plasticity index	(%)	8.7	5.8	8.4
9.	Natural Density	g/cc	1.86	1.72	1.82
10.	Natural water content	(%)	11.42	6.86	7.08
11.	Direct Shear Test	Results have been given in sr. no 3 & 4			
12.	Specific Gravity	Unit less	2.48	2.55	2.62
13.	Permeability	cm/s	3.9x10 ⁻⁴	2.6x10 ⁻⁴	2.8x10 ⁻⁴
14.	Free Swell Index	(%)	0.012	0.037	0.011
15.	UCS (Unconfined Compressive Strength)	kPa	24.00	23.39	23.48

Table 4 Properties of undisturbed soil samples (**Kangnidhar Land Sinking**)

Sr. No	Property	Unit	Sample location	
			M/KA/TOE/1	M/KA/C/2
1	Dry unit weight	kN/m ³	15.00	16.32
2	Saturated unit weight	kN/m ³	16.12	17.60
3	Cohesion (c)	kPa	4.9	6.2
4	Angle of Internal Friction	Deg.	30.0	31.0
5	Modulus of elasticity	kPa	9600	10710
6	Poisson Ratio	Unitless	0.3	0.3
7	Grain Size Analysis ((GSD curves are shown in Figs 2a and 2b)			
	D ₆₀	mm	1.411	1.053
	D ₃₀	mm	0.379	0.295
	D ₁₀	mm	0.102	0.115
	C _u	Unit less	13.83	9.16
	C _c	Unit less	1.01	0.72
	Soil Classification		SW-SC	SP-SC
8	Atterberg Limit Tests			
	Liquid limit	(%)	27.9	31.1
	Plastic limit	(%)	20.8	22.2
	Plasticity index	(%)	7.1	8.9
9.	Natural Density	g/cc	1.64	1.79
10.	Natural water content	(%)	7.44	7.79
11	Direct Shear Test	Results have been given in sr. no 3 & 4		
12.	Specific Gravity	Unit less	2.60	2.49
13.	Permeability	cm/s	2.5x10 ⁻³	2.6x10 ⁻³
14.	Free Swell Index	(%)	0.025	0.00
15.	UCS (Unconfined Compressive Strength)	kPa	17.25	22.33

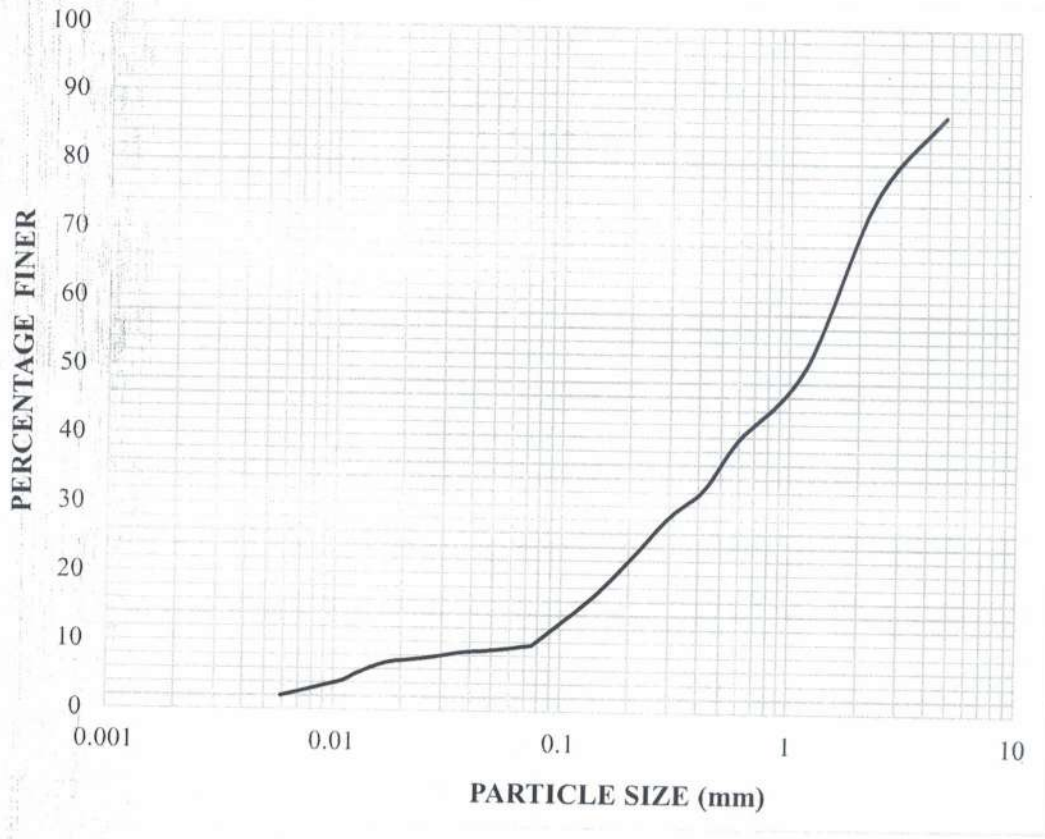

Fig. 1(a) Grain size distribution of soil samples M/T/TOE/1 (Tarna Hill, Land Sinking)

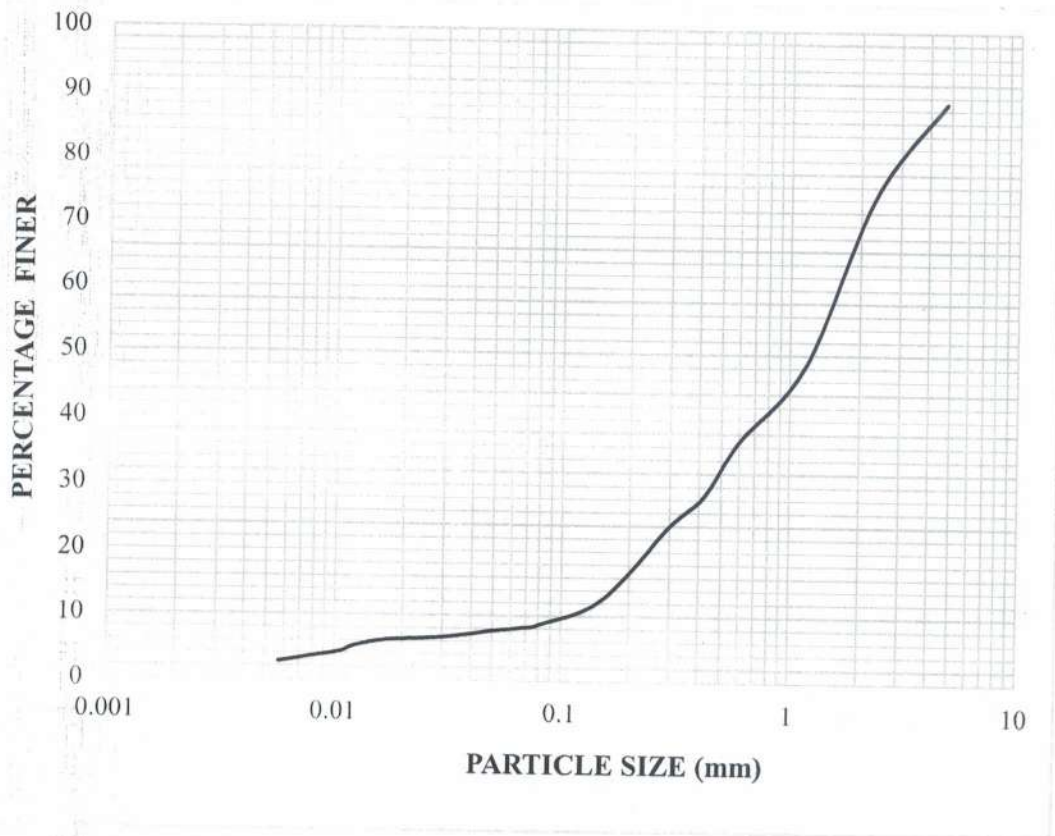

Fig. 1(b) Grain size distribution of soil samples M/T/BE/2 (Tarna Hill, Land Sinking)

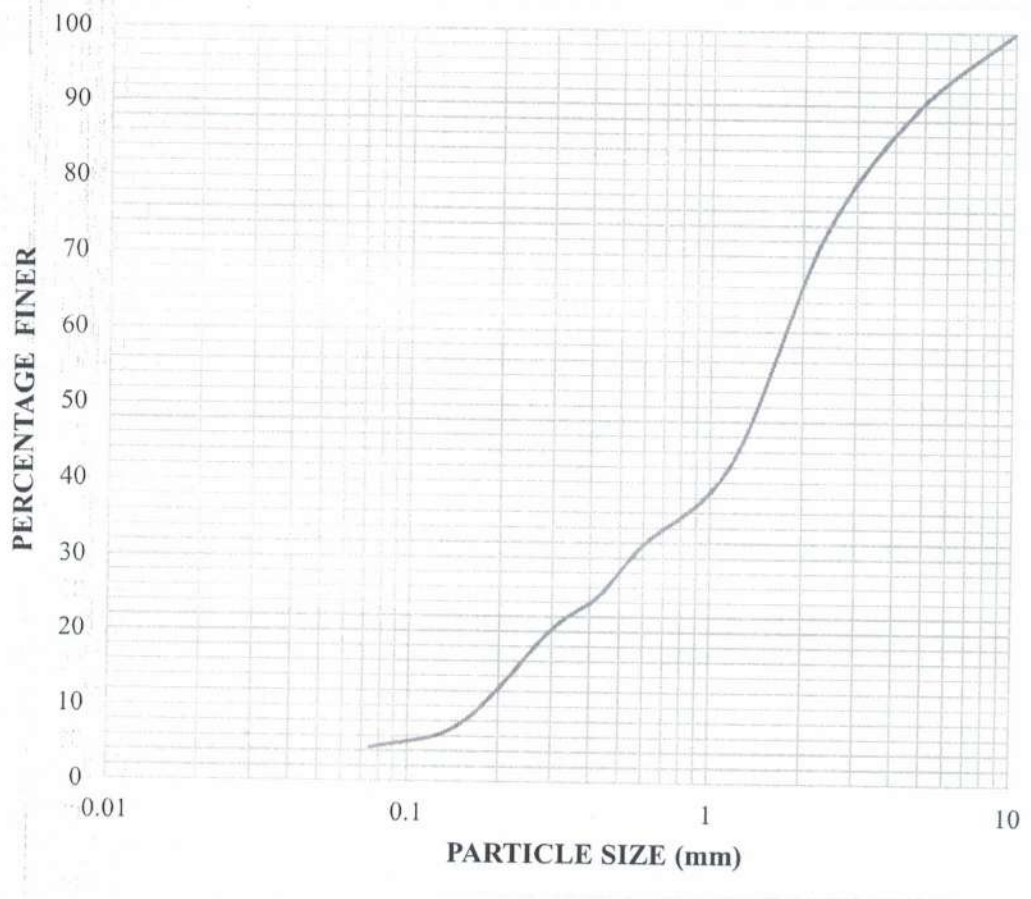

Fig. 1(c) Grain size distribution of soil samples M/T/C/3 (Tarna Hill, Land Sinking)

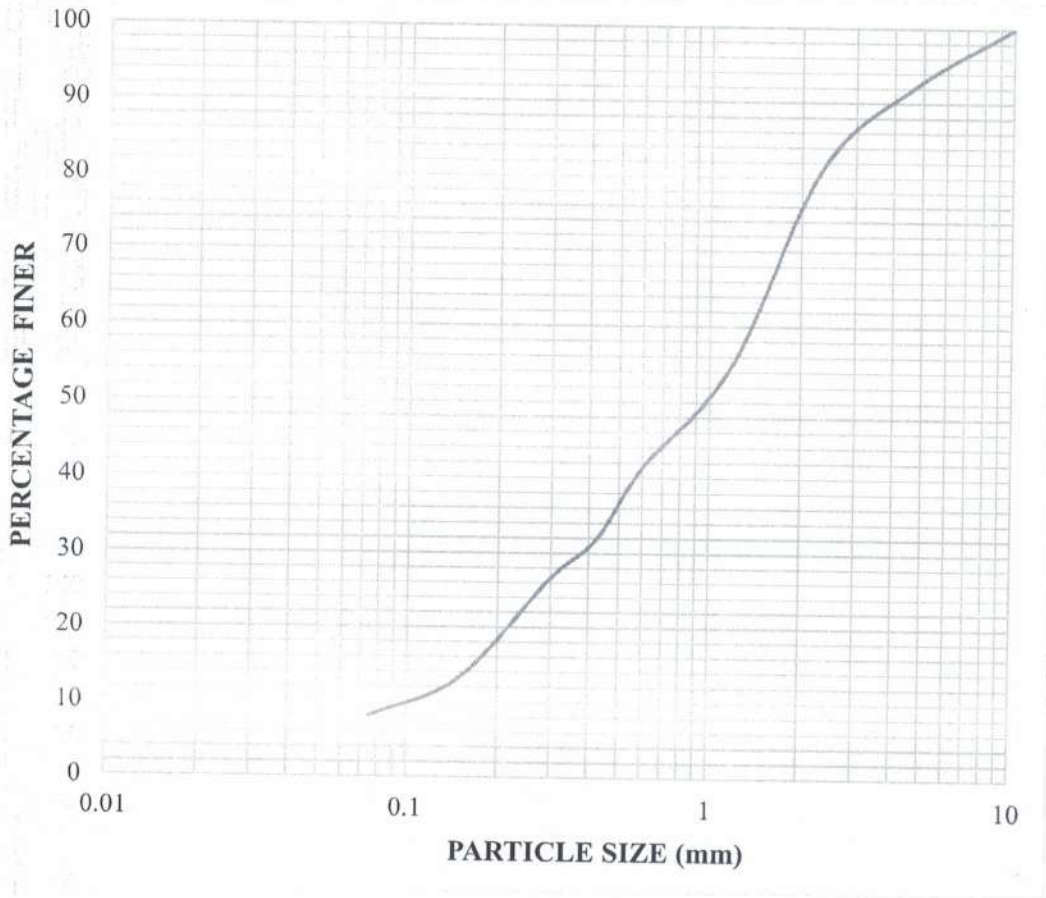

Fig. 2(a) Grain size distribution of soil samples M/KA/TOE/1 (Kangnidhar Land Sinking)

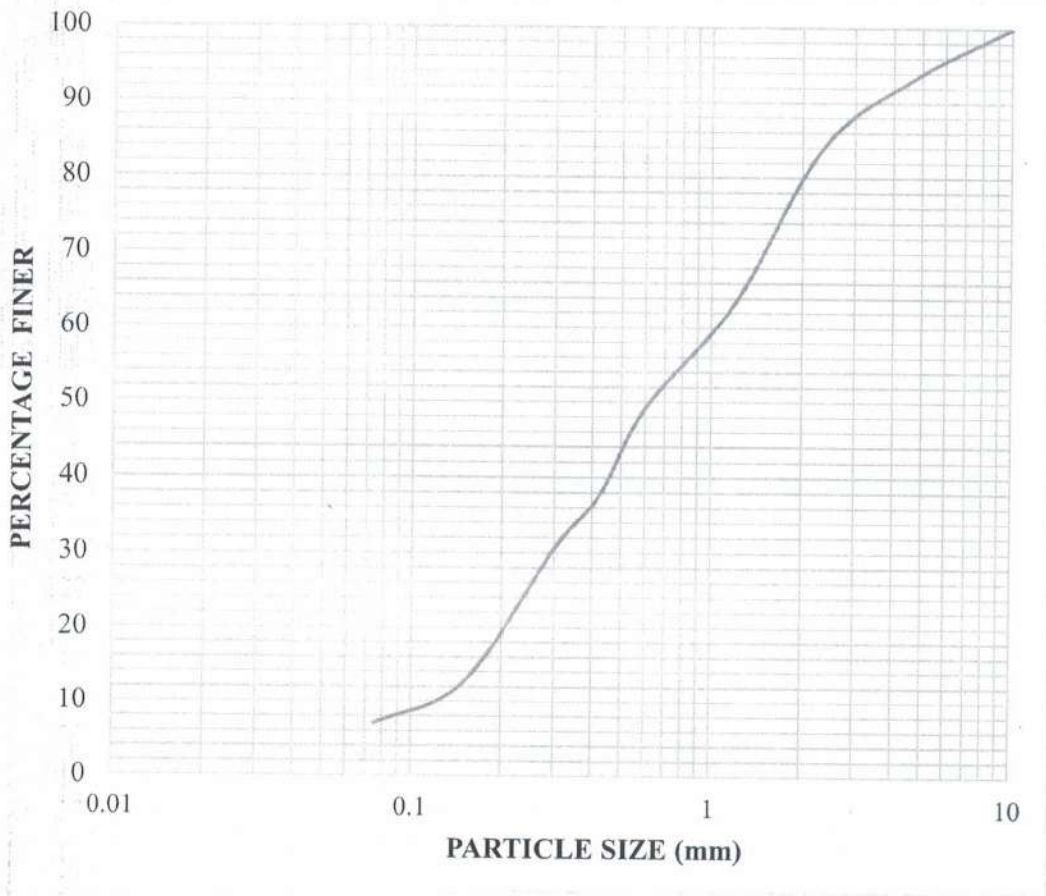
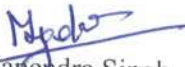

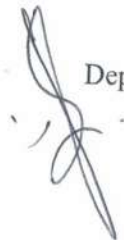

Fig. 2(b) Grain size distribution of soil samples M/KA/C/2 (Kangnidhar Land Sinking)

The results reported in this report are solely valid for the samples submitted by the client to the Department of Civil Engineering, National Institute of Technology Hamirpur (H.P.)

Dr Manendra Singh
Assistant Professor
Department of Civil Engineering
NIT Hamirpur

Dr R. S. Banshtu
Associate Professor
Department of Civil Engineering
NIT Hamirpur



DETAILED GEOLOGICAL MAP OF TARNA HILLS AT
MANDI DISTT. MANDI ,HIMACHAL PRADESH

Plate-I



MAP PREPARED BY:- SHREYASI MAHAPATRA & TRIPTI BABA,
SR. GEOLOGISTS, GSI CHANDIGARH.

SURVEYED BY:- SH. MANISH, SURVEYOR, DIV. II HPPWD
MANDI (H.P.)

DRAWN BY :- SH. SHER SINGH, SR. DRAUGHTSMAN (ARCH.)
O/O CHIEF ARCHITECT, HPPWD MANDI (H.P.)

GEOLOGICAL CROSS SECTION ALONG X-Y TARNA HILLS AT MANDI
DISTT. MANDI, HIMACHAL PRADESH.

LEGEND

SR.NO.	REFERENCES	SYMBOL
1.	Quartz Mica Schist	
2.	Zone of Depletion	
3.	Zone of Accumulation	
4.	Road	
7.	Retaining Wall	

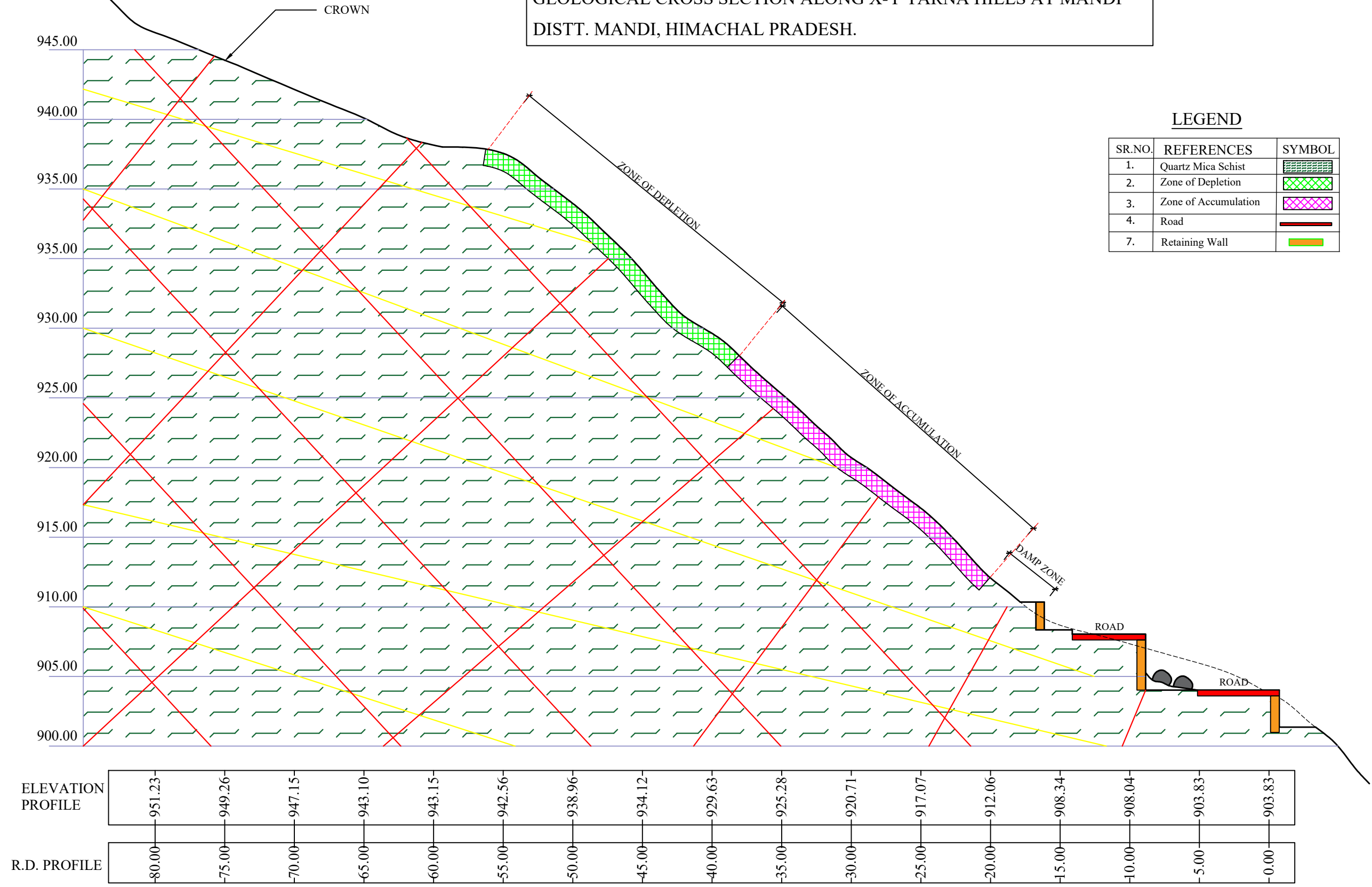
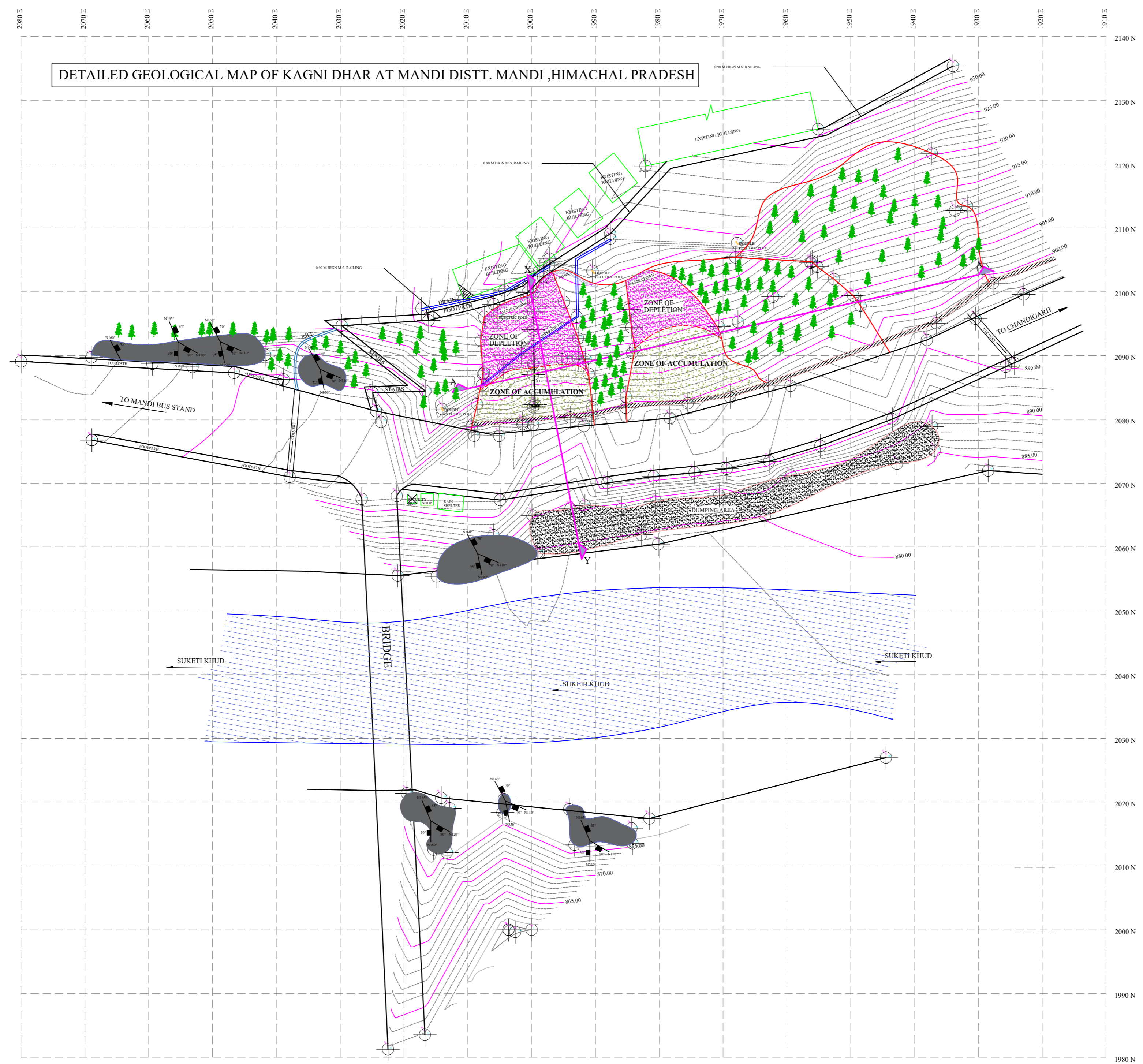
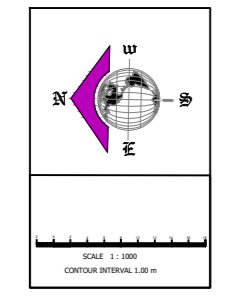

PLATE-III

DETAILED GEOLOGICAL MAP OF KAGNI DHAR AT MANDI DISTT. MANDI ,HIMACHAL PRADESH



SCALE 1:1000



LEGEND

SR.NO.	REFERENCES	SYMBOL
1.	CROWN	
2.	ZONE OF DEPLETION	
3.	ZONE OF ACCUMULATION	
4.	RETAINING /BREAST WALL	
5.	ELECTRIC POLE	
6.	ROAD/PATH	
7.	BUILDING	
8.	TREE	
9.	WALL	
10.	DRAIN PIPE	
11.	RIVER	
12.	MAJOR CONTOUR	
13.	ROCK OUT CROP	
14.	ATTITUDE OF BED	
15.	BUILDING WITH CRACK	
16.	RILL	
17.	STAIRCASE	

MAP PREPARED BY:- SHREYASI MAHAPATRA& TRIPTI BABA,
SR. GEOLOGISTS, GSI CHANDIGARH.

SURVEYED BY:- SH. MANISH, SURVEYOR, DIV. II HPPWD
MANDI (H.P.)

DRAWN BY :- SH. SHER SINGH, SR. DRAUGHTSMAN (ARCH.)
O/O CHIEF ARCHITECT, HPPWD MANDI (H.P.)

GEOLOGICAL CROSS SECTION ALONG X-Y KANGNI DHAR AT MANDI
DISTT. MANDI, HIMACHAL PRADESH.

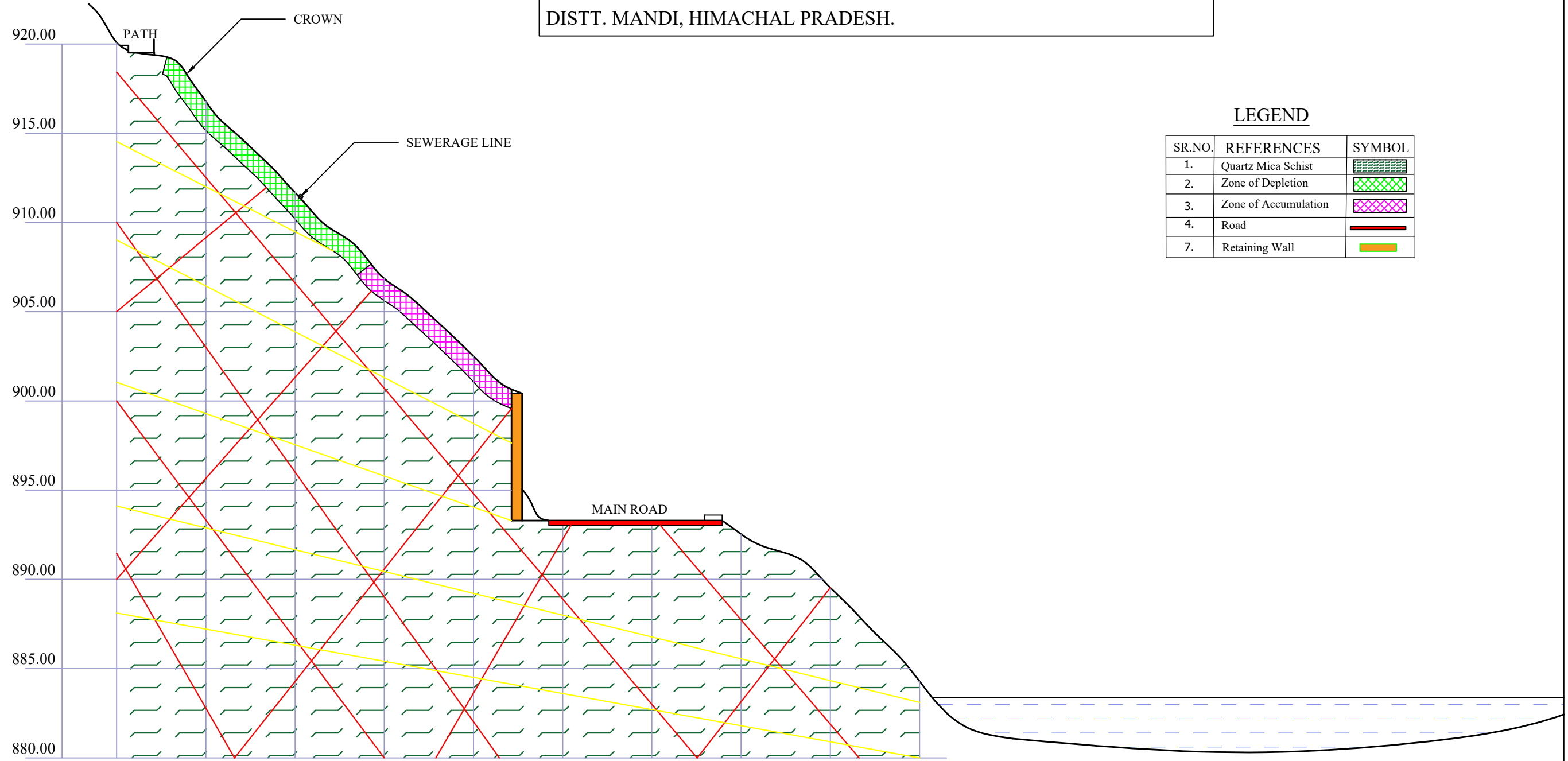

LEGEND

SR.NO.	REFERENCES	SYMBOL
1.	Quartz Mica Schist	
2.	Zone of Depletion	
3.	Zone of Accumulation	
4.	Road	
7.	Retaining Wall	

ELEVATION PROFILE	920.08	916.79	911.68	906.85	902.51	893.30	893.30	892.53	889.53	884.29
R.D. PROFILE	-45.00	-40.00	-35.00	-30.00	-25.00	-20.00	-15.00	-10.00	-5.00	0.00